



2003-2017 Gen III-V Viper Stainless Steel Sill Boss

Overview:

This kit replaces the sheet metal screws used to attach the sills and parts of the rear wheel well to the frame. The new fastener is a stainless steel threaded boss and screw combination. Installation is not entirely permanent and could be reversed if desired back to the machine screws.

This update preserves the frame and prevents the possible scenario of a sheet metal screw stripping out the hole along with reducing corrosion.

Compatibility:

This hardware will fit any 2003-2017 Viper with 14 pieces of hardware to attach the bottom side of the sills. The Gen V also uses 8 of these fasteners to affix the rear wheel liner, an optional addition.

Construction:

Stainless steel threaded inserts and hardware, screws and washers coated with black oxide.

Ordering Information: <http://dougshelbyengineering.com/>

Installation Guide: *(Excerpts from the Gen V Service Manual – see the manual for the year specific to the Viper in question)*

Remove The Side Sills

NOTE: Left side shown, right side typical.

1. Open the door and remove the fasteners (2) from the sill trim panel (1).
2. Raise and support the vehicle,
3. Remove the rear wheelhouse splash shield liner (see the instruction on the following page)
4. Remove the fasteners (1) securing the sill trim panel (3) to the quarter panel (2).



Stainless Steel Threaded Frame Insert and Sill Screws

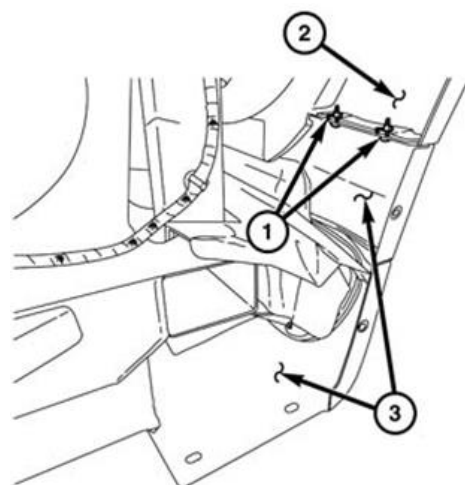
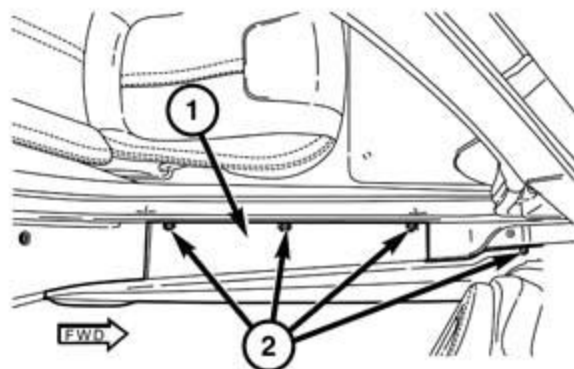

- Remove the fasteners (1) from the bottom sill trim panel (2).

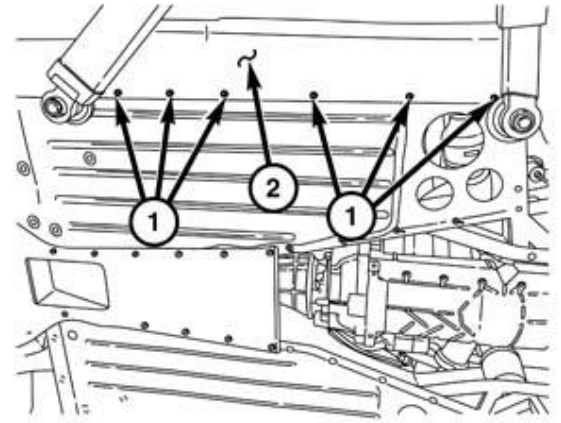

- Mark the location of the front sill fasteners (1), for proper alignment during installation.
- Remove the front wheelhouse splash shield to sill fasteners (3).
- Remove the fastener from the hood stabilizer bumper (2).

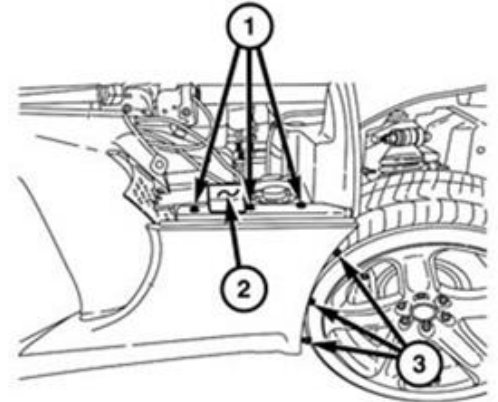

Remove the Rear Wheel Liner (Gen V):

- Remove the rear wheel, ([Refer to 22 - Tires and Wheels - Removal](#))
- Remove the fasteners (1) to the center belly pan.
- Remove the fasteners (2) to the trunk pan.
- Remove the sill trim panel fasteners (3).
- Remove the upper fastener (4) from the rear wheelhouse splash shield.
- Remove the rear belly pan fasteners (5).

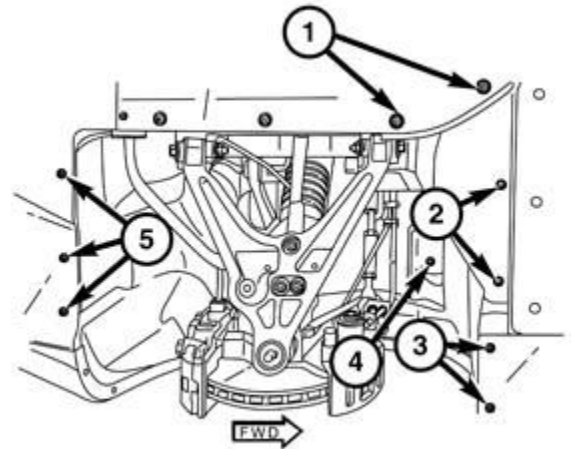

231374986

- Remove the fasteners (1) from the rear fascia.
- Remove the fasteners (2) from the quarter panel.
- Remove the fasteners (3) from the sill trim panel.

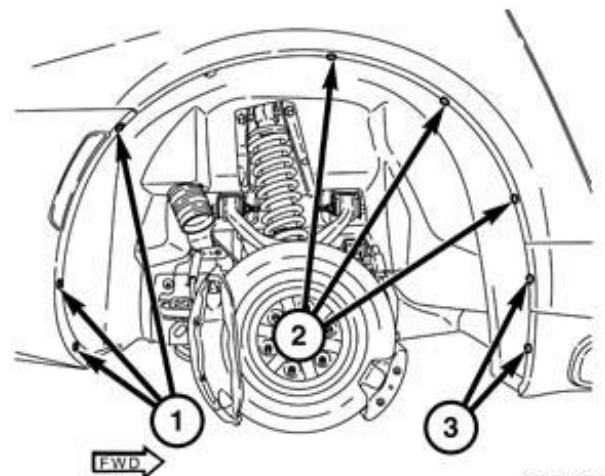

231374987

10. Remove upper fastener (1) and push pin (3).
11. Route the rear wheelhouse splash shield off of the outer edges.
12. Lower the rear wheelhouse splash shield and route the rear brake air duct (2) from the rear wheelhouse splash shield.
13. Remove the rear wheelhouse splash shield from the vehicle.

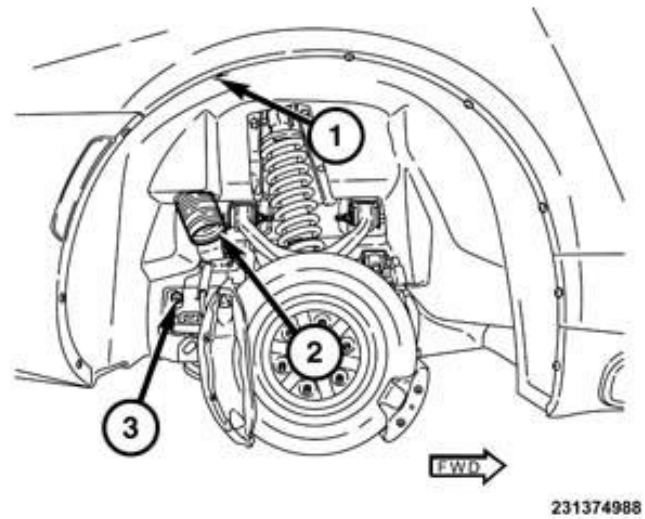

Drill and tap the holes:

Use the included drill bit to slightly enlarge the existing holes. Take care to ensure the drill is as perpendicular as possible to the frame (use a level if necessary). There are 7 holes per side for the side sills and 4 holes per side for the Gen V rear wheel well liner. See diagram on the next page for locations of the 4 Gen V wheel liner fasteners.

Use the included tap to thread the holes. Again, take care to ensure the tap is as perpendicular as possible to the frame. Lubricate the tap and turn slowly until fully threaded through. Multiple passes will ensure effortless threading of the stainless boss.

Check for Frame Clearance:

Check that the full diameter of the flange can sit flush against the frame. It is possible some of the silicone adhesive will need to be removed or an excessive weld bead may need to be ground down to ensure a perfect fit. If a weld bead is ground down, paint over the exposed area to prevent rust.

Test Fit and Install the Stainless Steel Bosses:

Test fit the stainless steel boss in each hole. Do not fully install but ensure threading requires little effort and the flange is roughly parallel to the frame. Remove the boss.

If necessary, tap the threads again or remove silicone / weld bead until the boss threads well and has no frame interference. If changes have been made, retest the boss fit and repeat until you are satisfied.



Tighten the sill boss using the Included Hardware

Apply Restobond 907TS to the outer thread of the boss (take care not to apply to the inner threads). This is a high temperature Loctite that will greatly reduce the risk of the boss backing out once installed but should still allow it to be removed in the future if necessary.

Tighten the boss fully until the base leaves little or no clearance against the frame. The included screws can be used to assist with tightening as shown. Do not over-tighten (use a lower torque drill setting).

The sills and wheel splash shield can be reinstalled immediately. The rear wheel liner hardware includes a larger washer to help secure the screw against the plastic. The hardware has a built-in lock washer for convenience but can also be secured with a small amount of Loctite 242. If desired or necessary a loose larger diameter washer can be installed to further spread the load across the sill holes. Take care to not over-torque the fastener.



Fully Installed Stainless-Steel Boss



Sill Installed Using New Hardware

**Location of 4 fasteners on Gen V
Rear Wheel Well (passenger side)**

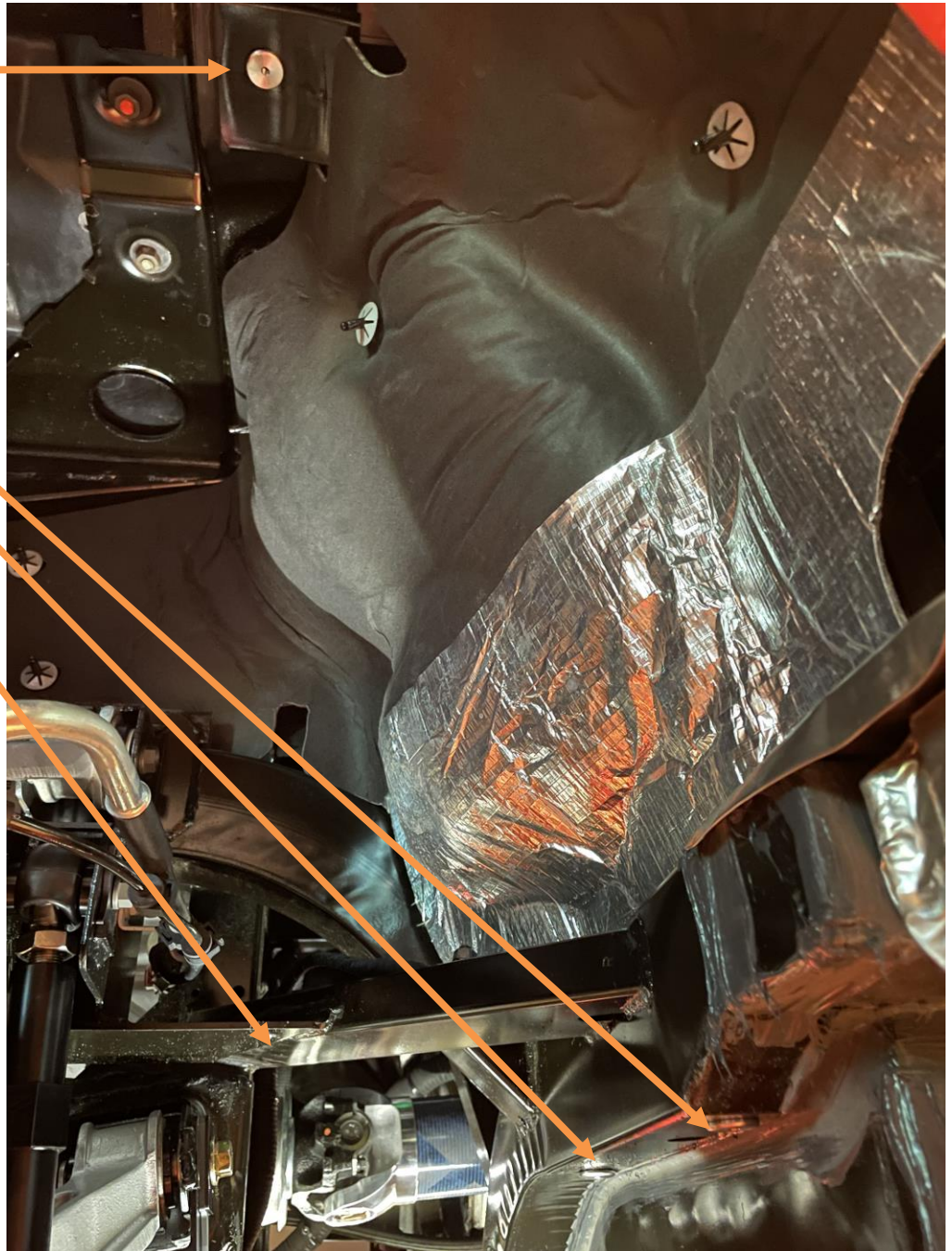

Inspection and Maintenance:

- Periodically inspect the fasteners to ensure they remain tight.
- If desired, larger washers can be added to the sill screws to spread the surface area over a larger hole.
- The inner thread of the boss is 8-32 if alternative hardware is desired.
- If needed the boss can be removed using pliers to grip the outer flange.

RESBOND™ 907TS RED THREADLOCKER

Use From -300°F to 2100°F

POTENTIAL HEALTH EFFECTS Primary Route Of Entry: Inhalation, Ingestion And Skin Irritation. Effects Of Overexposure: Currently, studies have shown that signs of slight dermatological irritation have occurred after prolonged skin contact. This product contains minor amounts of binders which burn out during first heat up. Emergency and First Aid Procedures Terminate Exposure.

EMERGENCY FIRST AID PROCEDURES Emergency and First Aid Procedures: Flush eyes with copious quantities of water. Get immediate medical attention for eyes. If swallowed, consult a physician immediately.

SPILL OR LEAK PROCEDURES Recommended Procedures: If spilled mix with water and disposed in approved industrial waste container. Hose down spilled wet cement paste with water immediately. Cement is not water soluble after setting up.

HANDLING AND STORAGE Storage: Keep containers sealed and clearly labeled. Handling: Keep container closed when not in use. Avoid getting powder in body openings, including: cuts, sores, mouth, etc. Wash hands thoroughly before eating or smoking.

Thank you for your purchase!

Your business is appreciated and customer satisfaction is our top priority! Don't hesitate to contact us via email with any questions or feedback. Word of mouth is the best form of advertising so if you are satisfied, please spread the word!

Disclaimer of Liability:

Doug Shelby Engineering assumes no liability expressed or implied for the improper installation or use of this product or its components. Doug Shelby Engineering is NOT responsible for any damage, consequential or otherwise for equipment failure after installation.

Vehicle Modification:

Modification of your vehicle with the parts identified above may alter its stock performance; the buyer hereby expressly assumes all risks associated with any such modification.

Disclaimer of Warranty:

Seller disclaims any warranty express or implied with respect to the parts sold hereby whether as to merchantability, fitness for particular purpose, or any other matter.