



1992-2017 Gen I-V Viper Steering Upgrades

Overview:

The suite of steering upgrades for all Gen Dodge Vipers includes steering rack inner tie rods, rack stops, bellows/boots, and titanium rack bolts.

Rack Stops: Stronger than the OEM plastic which are prone to breaking

Bellows/Boots: Flexible neoprene upgrade from the OEM version. Includes OEM style clamps.

Ti Rack Bolts: Set of 2 titanium bolts coated in Teflon infused anodizing saves weight over OEM. Includes Type III hard anodized black aluminum washer.

Inner Tie Rods: Improved over OEM which can pull out over time with heavy track use. Cadmium plated 4340 steel, aerospace grade bearing with PTFE liner. Lower friction and higher strength than OEM.



Gen II Inner Tie Rod, Bellows, and Rack Stop

Compatibility:

Compatibility with all 1992-2017 Vipers. Inner tie-rods designs are common between Gen I and II and III-V.

Construction:

Various materials (see above)

Ordering Information:

<http://dougshelbyengineering.com/Viper.html>

Installation Guide:

Outer Tie Rod Removal (excerpt from Gen V Service Manual – Consult Specific Manual for Details:

1. Raise and support vehicle.
2. Remove front wheel and tire assembly.
3. Loosen inner-to-outer tie rod adjuster jam nut (2).

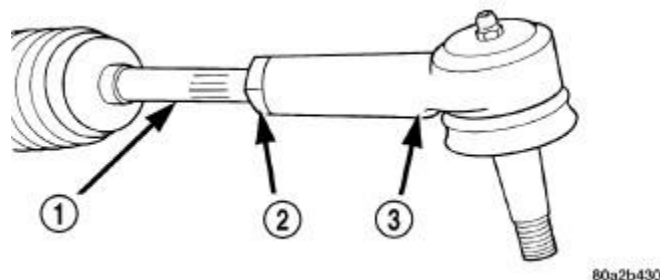

4. Remove nut (3) from outer tie rod.

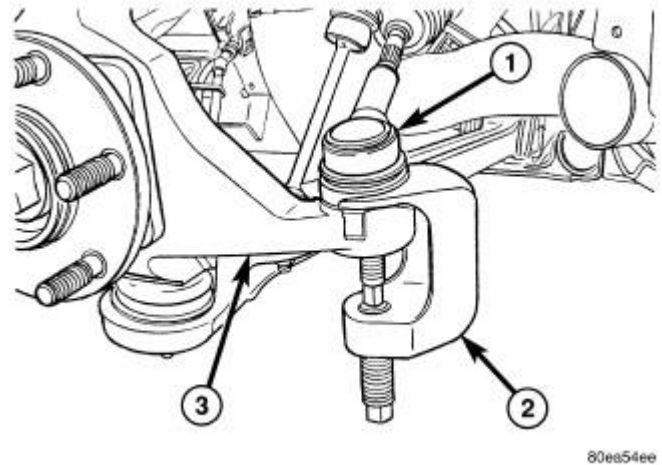
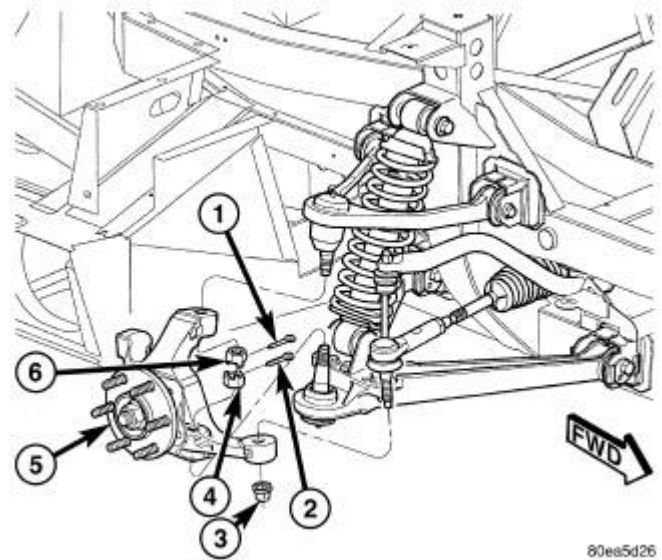

CAUTION: When releasing outer tie rod (1) from knuckle (3) using Puller (2), Special Tool C-4150A, use care not to pinch and damage tie rod grease seal.

5. Release outer tie rod (1) from knuckle (3) using Puller (2), Special Tool [C-4150A](#) .
6. Remove outer tie rod by unthreading it from inner tie rod.

Bellows Removal:

Remove clamps on either end of the bellows. Slide bellows off by pulling it over the inner tie-rod.

Inner Tie-Rod Removal:

Unthread inner tie rod from steering rack using a 34mm wrench.

Rack Stop Removal and Installation:

Remove the rack stop by sliding it away from the steering rack. Install new rack stop in the opposite manner.

Inner Tie-Rod Installation:

Apply Loctite to the male tie-rod or steering rack thread. Thread inner tie rod onto steering rack using a 34mm wrench. Tighten to approximately 100 lb-ft

Bellows Installation:

Slide bellows on by pulling it over the inner tie-rod. Crimp the included clamps using a pinch clamp plier such as McMaster-Carr P/N 6541K69

Outer Tie Rod Installation (excerpt from Gen V Service Manual – Consult Specific Manual for Details):

NOTE: Before installing outer tie rod end on inner tie rod, be sure jam nut (2) is on inner tie rod (1).

1. Thread outer tie rod (3) onto inner tie rod (1). Snug inner-to-outer tie rod adjuster jam nut (2). Do not tighten jam nut until wheel alignment toe has been set.
2. Install outer tie rod onto steering knuckle (5). Install NEW tie rod nut (3) and tighten nut to the proper (Torque Specifications).

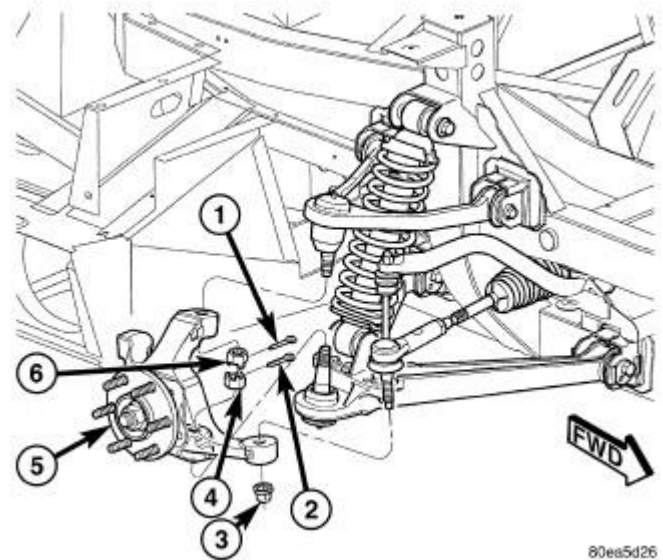

80ea5d26

DESCRIPTION	N-m	Ft. Lbs.	In. Lbs.	COMMENT
Tie Rod Adjuster Jam Nut	75	55	—	
Tie Rod Knuckle Nut	30 Plus 175°	22 Plus 175°	—	Do not reuse fastener. If removed, a new fastener must be installed and tightened to specifications.

3. Install tire and wheel assembly
4. Lower vehicle.
5. Check wheel alignment and adjust toe as necessary.

Titanium Steering Rack Bolt Installation:

Remove bolts one side at a time taking care to maintain rack to frame spacers (may be done in conjunction with steering rack bushings). Inspect area for damage or need to replace bushings and other parts.

Install bolt and tighten to 150 ft-lbs. Repeat steps for other side.

Inspection and Maintenance:

Periodically inspect all parts to ensure there is no damage and everything is sufficiently tightened.

Thank you for your purchase!

Your business is appreciated and customer satisfaction is our top priority! Don't hesitate to contact us via email with any questions or feedback. Word of mouth is the best form of advertising so if you are satisfied please spread the word!

Disclaimer of Liability:

Doug Shelby Engineering assumes no liability expressed or implied for the improper installation or use of this product or its components. Doug Shelby Engineering is NOT responsible for any damage, consequential or otherwise for equipment failure after installation.

Vehicle Modification:

Modification of your vehicle with the parts identified above may alter its stock performance; the buyer hereby expressly assumes all risks associated with any such modification.

Disclaimer of Warranty:

Seller disclaims any warranty express or implied with respect to the parts sold hereby whether as to merchantability, fitness for particular purpose, or any other matter.