

Wio-WM1110 Module

LoRa Wireless Module – Powered by Semtech

Datasheet

V1.1

Content

Content.....	2
1 Introduction.....	1
1.1 Feature.....	2
2 Description.....	5
2.1 System Diagram.....	6
2.2 Pin definition.....	7
3 Electrical characteristics.....	10
3.1 Maximum Ratings.....	10
3.2 Normal working conditions.....	11
3.3 Module specifications.....	11
4 Application information.....	12
4.1 Package information.....	12
4.2 Land Pattern.....	13
4.3 Package Marking.....	14
4.4 Reference design based on WM1110 module.....	15
5 Ordering information.....	16
6 Reversion.....	16

1 Introduction



The Wio-WM1110 is a fusion positioning module for developing low-power, long-range IoT applications. It's embedded with Semtech LR1110 and Nordic nRF52840, features Semtech's LoRa technology for long-range wireless communication, GNSS, Wi-Fi, and Bluetooth for location tracking services.

1.1 Feature

- **Low-Power High-Sensitivity LoRaWAN® Network** : Support the global LoRaWAN® frequency plan
- **Multi-Purpose Radio Front-End Targeting Geolocation Purposes:** GNSS (GPS/ BeiDou)、Wi-Fi、Bluetooth, suitable for indoor and outdoor positioning
- **Nordic nRF52840 Bluetooth 5.3 SoC:** Support Bluetooth Low Energy, Bluetooth mesh, NFC, Thread and Zigbee
- **Low-power Consumption:** 7.6 μ A in sleep mode
- **FCC, CE,Telec Certified**

This product specification includes a detailed description of the WM1110 module's performance and functions. For the latest firmware, product updates or errata, please contact Seeed Studio.

2 Description

Wio-WM1110 module is embedded with high-performance [Semtech LR1110](#) and [Nordic nRF52840](#), providing developers with low-power, long-range LoRaWAN® communication, and covering the global frequency band, making it highly versatile and adaptable to various low-power wide-area IoT scenarios like smart agriculture, wireless meter reading, and smart city applications.

The Wio-WM1110 module also utilizes GNSS (Global Navigation Satellite System) tracking for outdoor applications, additionally, the Wi-Fi passive scanning and Bluetooth mesh are suitable for the IPS(Indoor Positioning System), providing all-around location coverage while reducing complexity and cost. It's a perfect development platform for asset tracking、inventory management、asset loss and theft prevention, etc. Learn more about the [LoRa Edge™ LR1110 solution](#).

2.1 System Diagram

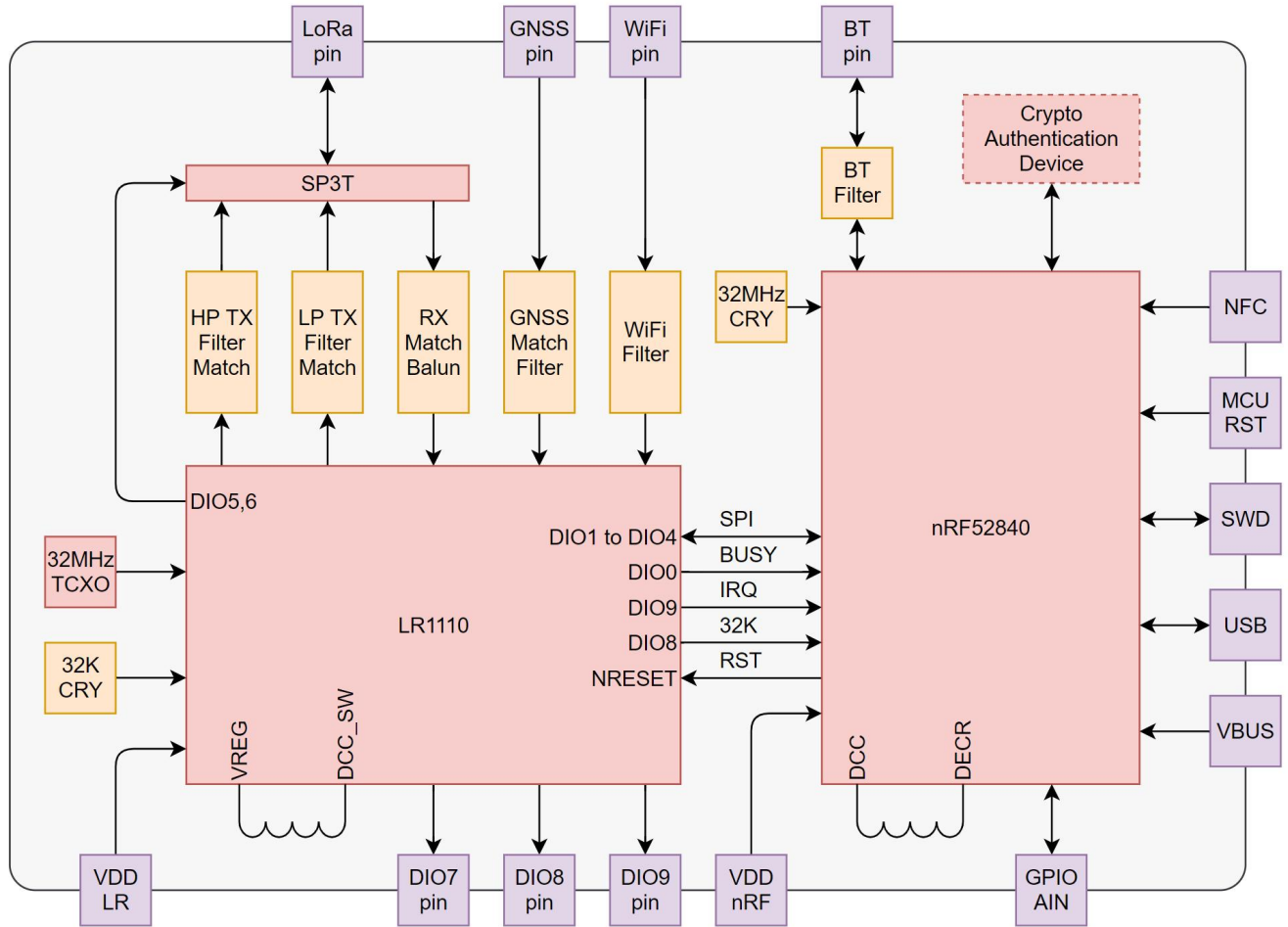

Figure 1 WM1110 Schematic diagram

2.2 Pin definition

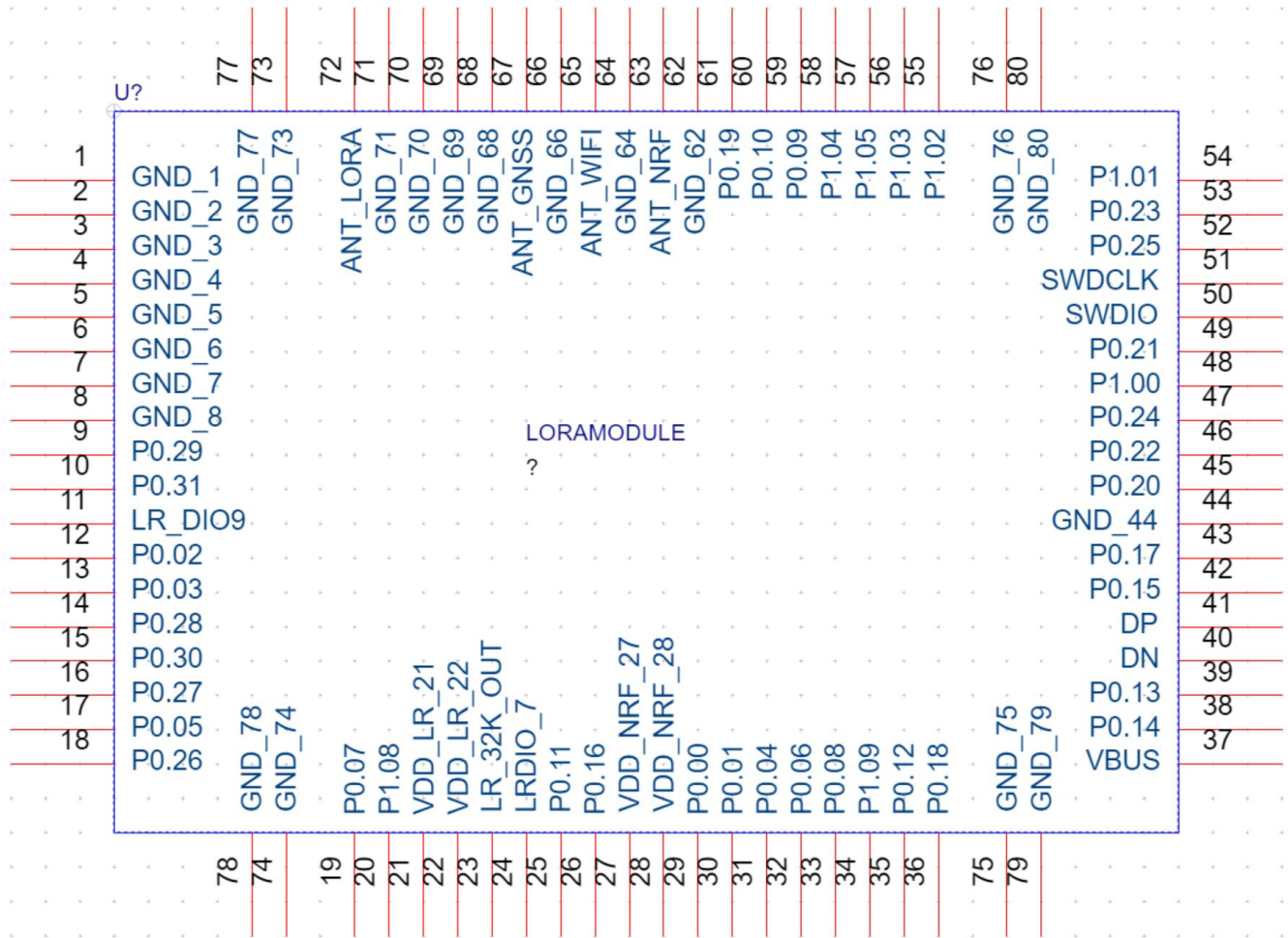

Figure 2 WM1110 Pin arrangement

Table 1 WM1110 pinout

Number	Name	Type	Description
1	GND	-	Ground
2	GND	-	Ground
3	GND	-	Ground
4	GND	-	Ground
5	GND	-	Ground
6	GND	-	Ground
7	GND	-	Ground
8	GND	-	Ground

9	P0.29	I/O	MCU GPIO P0.29
10	P0.31	I/O	MCU GPIO P0.31
11	LR_DIO9	O	LR1110 DOUT
12	P0.02	I/O	MCU GPIO P0.02
13	P0.03	I/O	MCU GPIO P0.03
14	P0.28	I/O	MCU GPIO P0.28
15	P0.30	I/O	MCU GPIO P0.30
16	P0.27	I/O	MCU GPIO P0.27
17	P0.05	I/O	MCU GPIO P0.05
18	P0.26	I/O	MCU GPIO P0.26
19	P0.07	I/O	MCU GPIO P0.07
20	P1.08	I/O	MCU GPIO P1.08
21	VDD_LR	-	Supply voltage for Lora
22	VDD_LR	-	Supply voltage for Lora
23	LR_DIO8	O	LR1110 DOUT
24	LR_DIO7	O	LR1110 DOUT
25	P0.11	I/O	MCU GPIO P0.11
26	P0.16	I/O	MCU GPIO P0.16
27	VDD_NRF	-	Supply voltage for Bluetooth
28	VDD_NRF	-	Supply voltage for Bluetooth
29	P0.00	I/O	MCU GPIO P0.00
30	P0.01	I/O	MCU GPIO P0.01
31	P0.04	I/O	MCU GPIO P0.04
32	P0.06	I/O	MCU GPIO P0.06
33	P0.08	I/O	MCU GPIO P0.08
34	P1.09	I/O	MCU GPIO P1.09
35	P0.12	I/O	MCU GPIO P0.12

36	P0.18	I/O	MCU GPIO P0.18
37	VBUS	I/O	MCU GPIO VBUS
38	P0.14	I/O	MCU GPIO P0.14
39	P0.13	I/O	MCU GPIO P0.13
40	DN	I/O	MCU USB DN
41	DP	I/O	MCU USB DP
42	P0.15	I/O	MCU GPIO P0.15
43	P0.17	I/O	MCU GPIO P0.17
44	GND	–	Ground
45	P0.20	I/O	MCU GPIO P0.20
46	P0.22	I/O	MCU GPIO P0.22
47	P0.24	I/O	MCU GPIO P0.24
48	P1.00	I/O	MCU GPIO P1.00
49	P0.21	I/O	MCU GPIO P0.21
50	SWDIO	I/O	MCU SWDIO
51	SWDCLK	I	MCU SWDCLK
52	P0.25	I/O	MCU GPIO P0.25
53	P0.23	I/O	MCU GPIO P0.23
54	P1.01	I/O	MCU GPIO P1.01
55	P1.02	I/O	MCU GPIO P1.02
56	P1.03	I/O	MCU GPIO P1.03
57	P1.05	I/O	MCU GPIO P1.05
58	P1.04	I/O	MCU GPIO P1.04
59	P0.09	I/O	MCU GPIO P0.09
60	P0.10	I/O	MCU GPIO P0.10
61	P0.19	I/O	MCU GPIO P0.19
62	GND	–	Ground

63	ANT_NRF	RFIO	Bluetooth Antenna
64	GND	–	Ground
65	ANT_WIFI	RFIO	WIFI SCAN Antenna
66	GND	–	Ground
67	ANT_GNSS	RFIO	GNSS Antenna
68	GND	–	Ground
69	GND	–	Ground
70	GND	–	Ground
71	GND	–	Ground
72	ANT_LORA	RFIO	LORA Antenna
73	GND	–	Ground
74	GND	–	Ground
75	GND	–	Ground
76	GND	–	Ground
77	GND	–	Ground
78	GND	–	Ground
79	GND	–	Ground
80	GND	–	Ground

3 Electrical characteristics

3.1 Maximum Ratings

Reaching or exceeding the maximum ratings listed in the table below can cause equipment damage.

Table 2 Absolute Maximum Ratings

Item	Description	min	max	unit
VDD_LR	Lora supply voltage	-0.5	+3.9	V
VDD_NRF	MCU supply voltage	-0.3	+3.9	V
VBUS	MCU USB VBUS	-0.3	+5.8	V
P_NRF	Bluetooth RF input power		+10	dBm
P_LR	Lora RF input power	-	+10	dBm

3.2 Normal working conditions

Table 3 Recommended Operating Conditions

Item	Description	min	max	unit
VDD_LR	Lora supply voltage	+1.8	+3.7	V
VDD_NRF	MCU supply voltage	+1.7	+3.6	V
VBUS	MCU USB VBUS	+4.35	+5.5	V
TA	Ambient temperature	-40	+85	°C
ML_GNSS	GNSS maximum input power		0	dBm
ML_LR	Lora maximum input power	-	0	dBm

3.3 Module specifications

Table 4 WM1110 features

ITEMs	Parameter	Specifications	Unit
Structure	Size	20(W) X 20(L) X 2.3(H)	mm
	Package	80 pin LGA Module	
Electrical	power supply	3.3V typical	V
	Sleep current	7.6uA (WDT on)	uA
Characteristics	Operation current (Transmitter+MCU)	125mA @ LoRa TX 22dBm	mA

	Operation current (Receiver+MCU)	10mA @ LoRa SF12 125 kHz				mA
		7mA @ Bluetooth Scan				
		7mA @ WiFi Scan				
	Output power	20dBm max @LoRa				dBm
		6dBm max @ Bluetooth				
	Sensitivity	SF				
SF7		min	type	max		
SF12		-	-125	-		
		-	-141	-		
Peripheral Interface	Full-speed 12 Mbps USB					
	QSPI/SPI/TWI/I ² S/PDM/QDEC					
	High speed 32 MHz SPI					
	Quad SPI interface 32 MHz					
	Manual reset pin input					

4 Application information

4.1 Package information

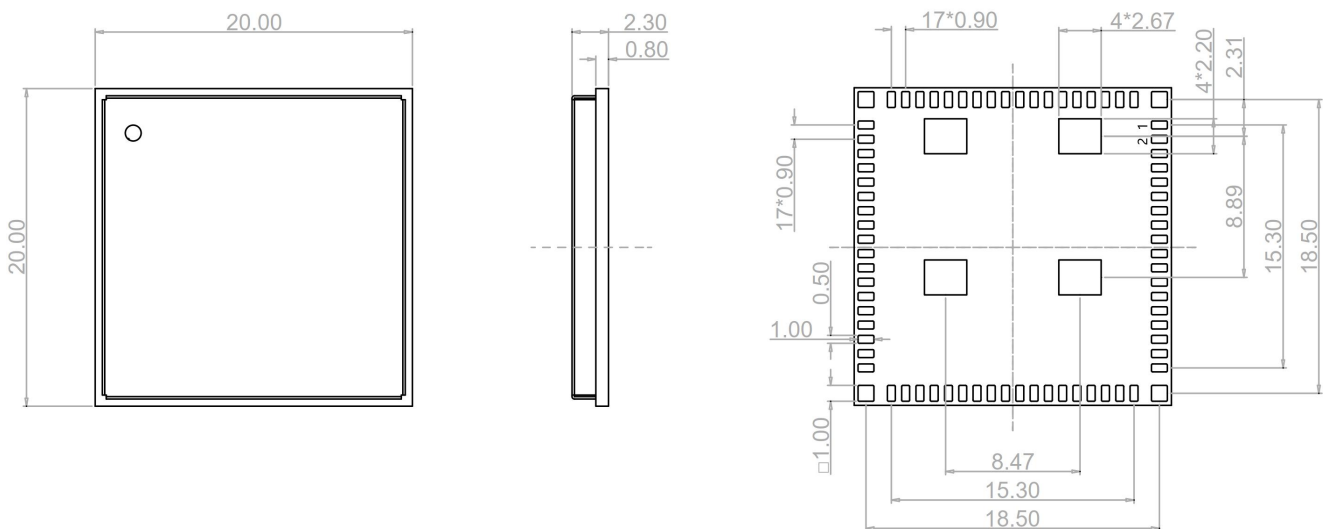

Figure 3 Package Outline Drawing

4.2 Land Pattern

The following figure shows the recommended pad dimensions.

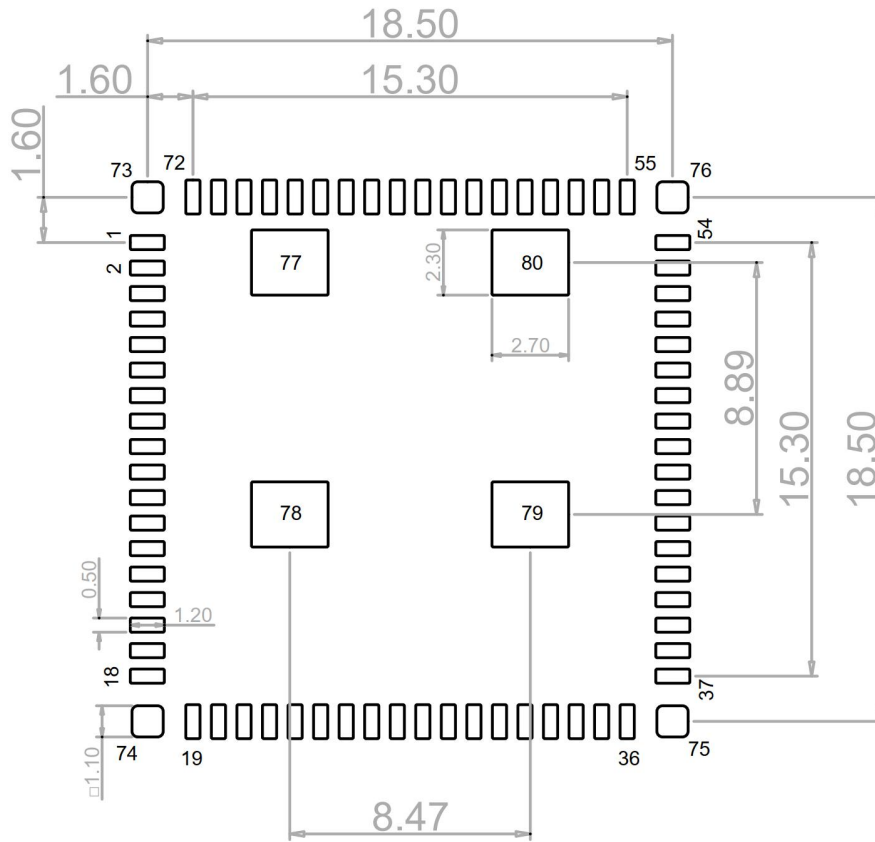

Figure 4 PCB Layout

4.3 Package Marking



4.4 Reference design based on WM1110 module

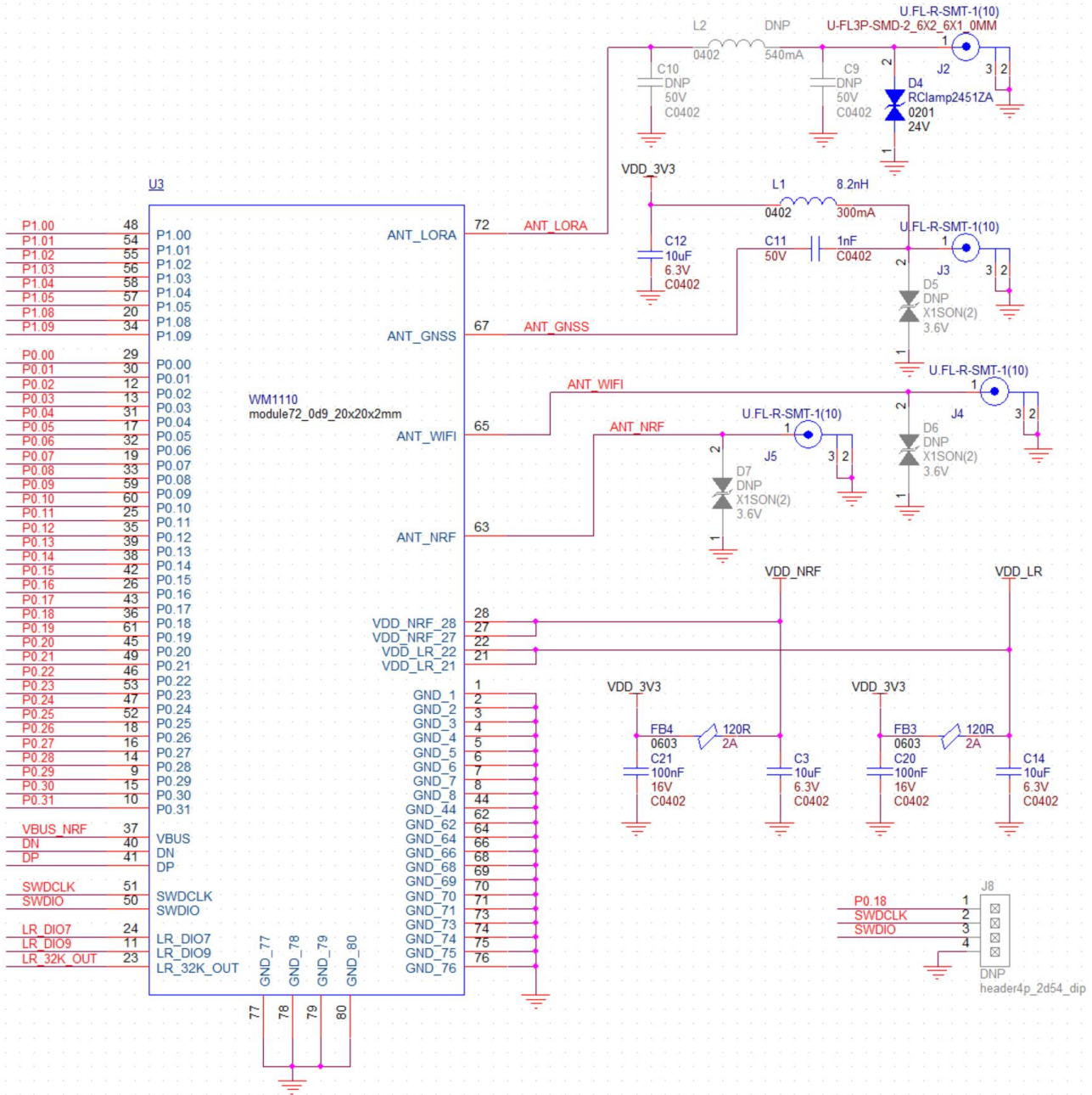

Figure 5 Reference design based on WM1110

P0.18 is configurable as RESET for MCU.

A Pi circuit maybe needed for antenna impedance matching, for the reference design, use a 0 Ohm resistor on L2.

5 Ordering information

Technical Support: sensecap@seeed.cc

Sales: iot@seeed.cc

Table 5 Ordering Information

Part Number	MCU	TX Power (dBm)	AT Modem
WM1110-LF	ROM 256KB / RAM 64KB	10@LF(434MHz) 22@LF (470MHz)	Yes
WM1110-HF	ROM 256KB / RAM 64KB	22@HF (868/915MHz)	Yes

6 Reversion

V1.0 2020-07-20 First release

V1.1 2023-04-23 Correct Module Naming