

Outdoor Enclosure Kit H D4/D4+/D4P

WisGate Developer D4 (RAK7244) Outdoor Case

Quick Assembly Guide

In this guide, the process of assembling and mounting an outdoor case for the RAK7244 WisGate Developer D4 will be shown step by step. Strict adherence to the steps guarantees a secured and durable outdoor casing.

Kit Inclusion

The package includes all the necessary parts for this project, without the RAK7244 WisGate Developer D4 itself.

1. Outdoor Enclosure Kit
2. PoE splitter Type-C USB (in 48 V; out 5 V/2.4 A)
3. PoE injector (in 100-240 V; out 48 V/0.5 A)
4. Power cord for the PoE Injector
5. Zip tie, PVC tape, and waterproof tape
6. Antenna cable type RG316, with N-type to RP-SMA male connectors for LoRa antenna
7. Antenna cable type RG316, with N-type to RP-SMA male connectors for LTE Antenna x2
8. Antenna cable type RG316, with N-type to SMA male connectors for GPS antenna
9. GPS Antenna with mounting brackets

Assembly

A detailed explanation of the procedure of putting the RAK7244 WisGate Developer D4 inside the RAKBox-GW-3 is shown.

1. Open the RAKBox-GW-3 enclosure. Remove the top cover and take out the mounting plate.

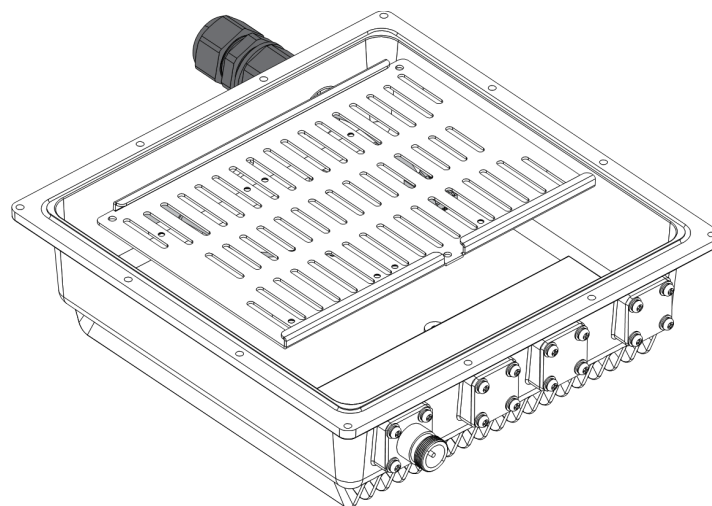

Figure 1: Mounting plate inside the RAKBox-GW-3 enclosure

2. Unscrew the four screws from the bottom cooling plate of the RAK7244 WisGate Developer D4. Do not remove the plate itself.

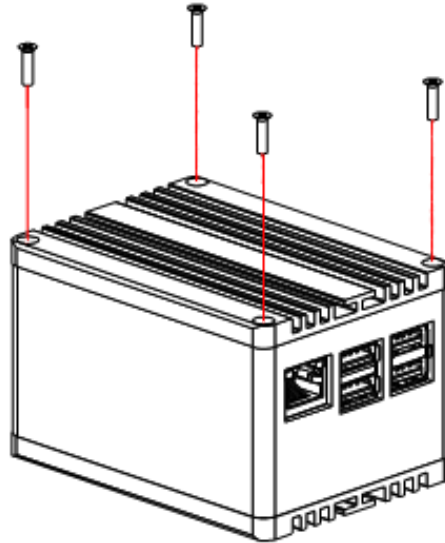

Figure 2: RAK7244 WisGate Developer D4

3. Align the RAK7244 WisGate Developer D4 to the proper holes of the mounting plate and fix it together with the previously removed screws.

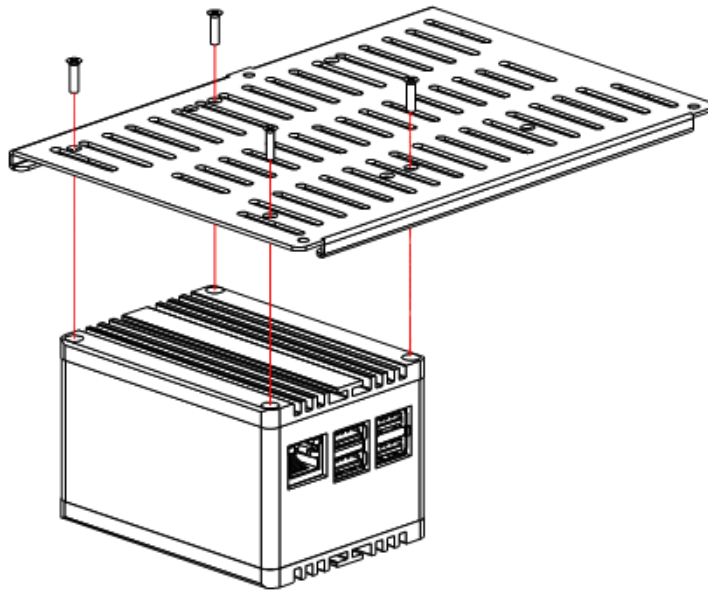

Figure 3: Fixing the RAK7244 WisGate Developer D4 to the mounting plate

4. Place the PoE splitter on the mounting plate and fix it with cable ties. Plug the RJ45 cable and USB type-C cable of the PoE splitter in the corresponding ports of the RAK7244 WisGate Developer D4.

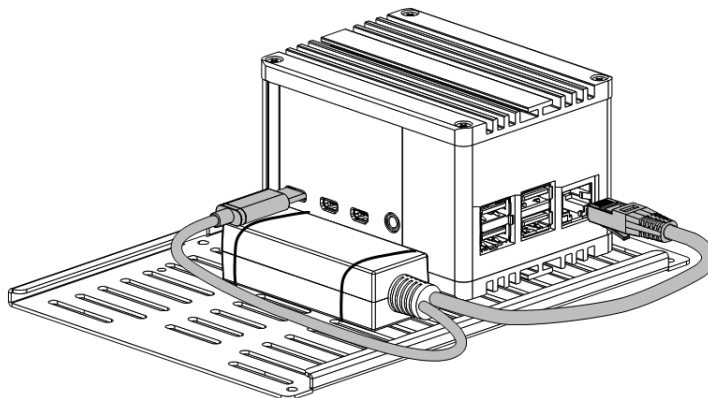

Figure 4: Placing and connection of the PoE Splitter

5. Put the mounting plate with the secured RAK7244 WisGate Developer D4 and PoE splitter back in the enclosure. Fix the plate with the screws.

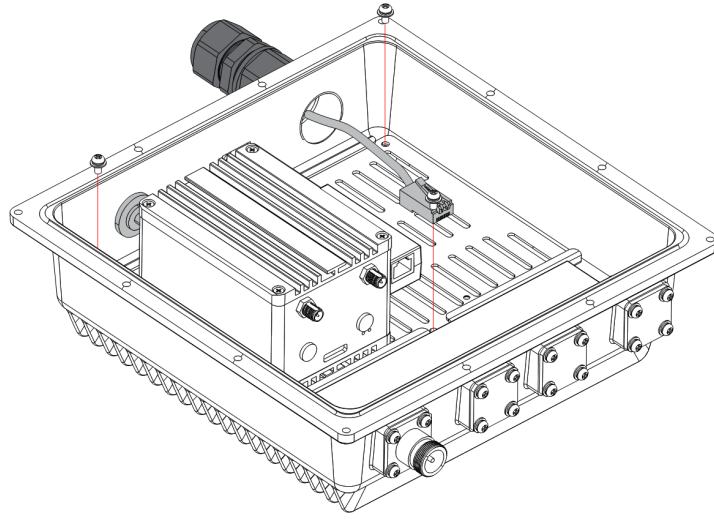

Figure 5: Fixing the mounting plate inside the enclosure

6. Plug the RJ45 Network cable coming out from the cable gland to the PoE splitters RJ45 port. Connect the RP-SMA male antenna connector of the enclosure to the RP-SMA female antenna connector of the RAK7244 WisGate Developer D4. Connect the SMA male GPS antenna connector of the enclosure to SMA female antenna connector of the RAK7244 WisGate Developer D4.

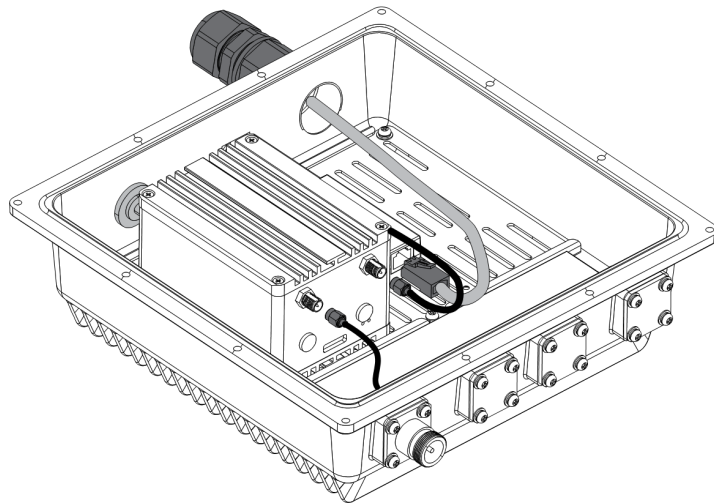

Figure 6: Connecting the network cable and the antennas

7. Close the RAKBox-GW-3's lid and fix it with the screws. Make sure that the rubber seal is placed correctly in the groove between the box and the lid to prevent leaks.

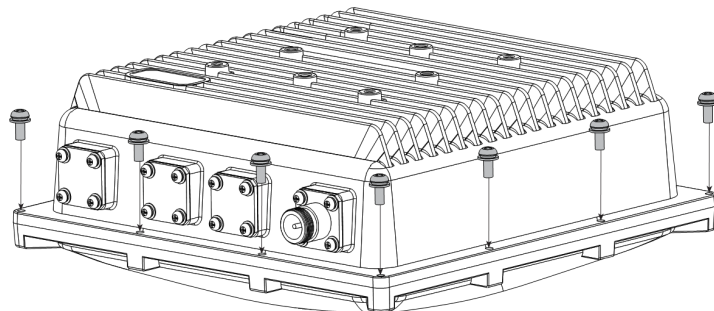

Figure 7: Closing the enclosure

Installation

Instructions on mounting and securing the mounting kit to the enclosure and the bearing pole.

1. Fix the included cross bracket on the bottom of the enclosure with four M6*12 bolts.

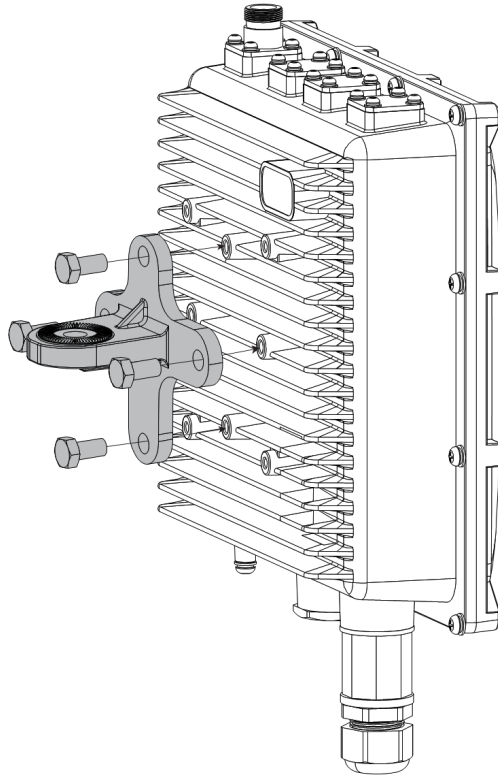

Figure 8: Mounting the cross bracket

2. Place two pieces of the clamp around the pole and tighten them with the included M6*110 bolts, washers, and nuts.

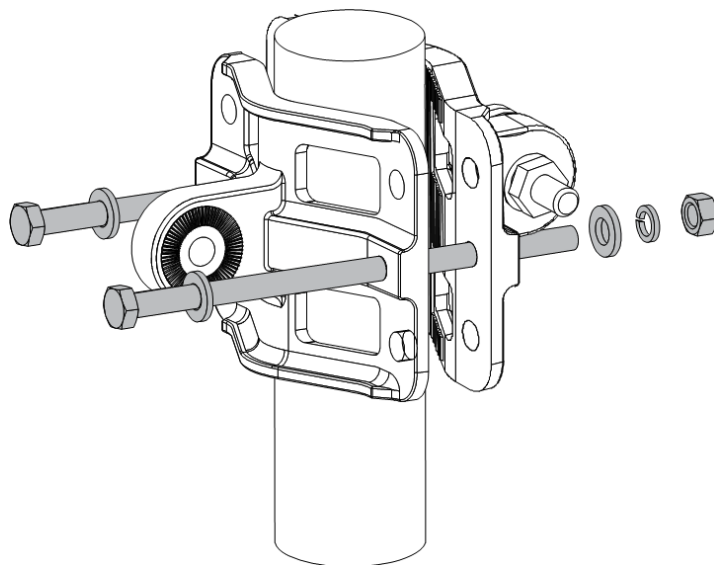

Figure 9: Mounting the clamp to the pole

3. Connect the pole clamp and the cross bracket by securing the last piece of the mounting kit in place using M6*30 bolts, washers, and nuts.

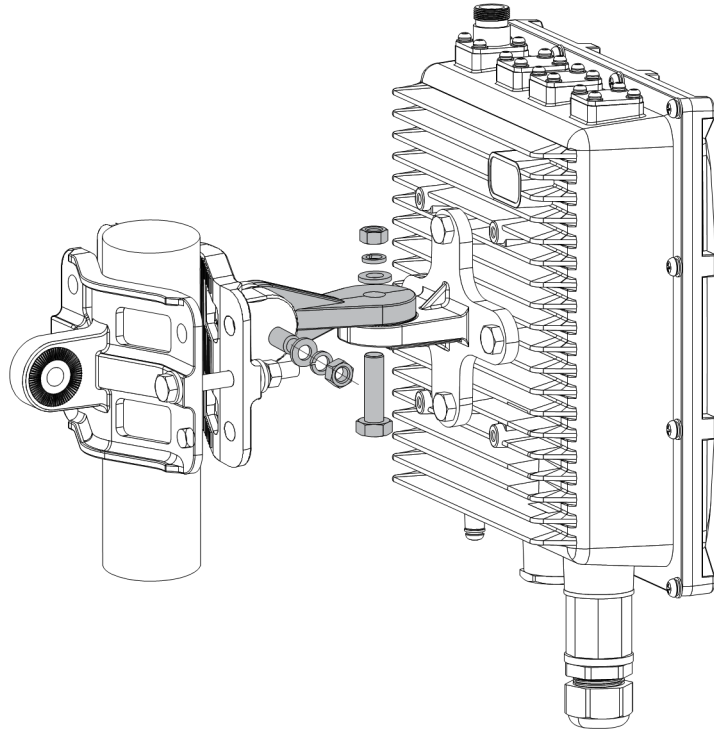

Figure 10: Fixing the enclosure to the pole clamp

Weather Protection

To better protect the Ethernet cable gland and the antenna connector from the weather, you need to cover them with PVC tape.

1. Clean the surface area of the connector that will be wrapped. Wrap a layer of PVC tape with a 50% overlap according to the rotation direction of the connector. Continue wrapping the PVC tape to about 10 mm below the end of the connector.

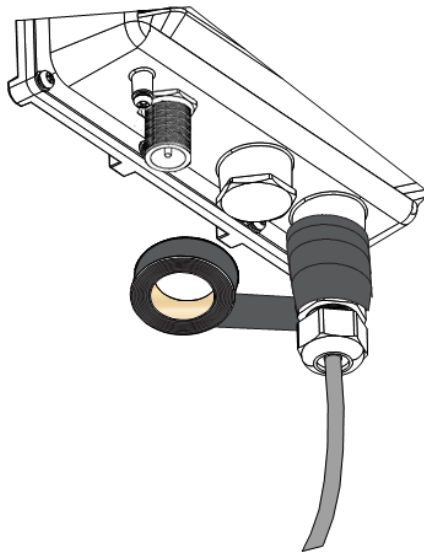

Figure 11: Wrapping with PVC tape

2. Cut off about 50 cm waterproof tape. Stretch it to double the length. Wrap three layers around the connector with a 50% overlap. Hold the tape in place with your hand for a few seconds.

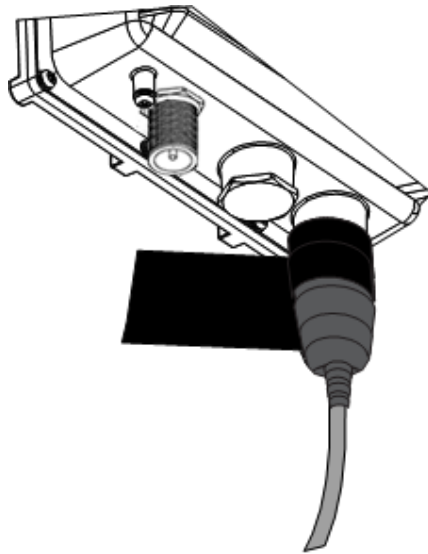

Figure 12: Wrapping with waterproof tape

3. Wrap three additional layers with PVC tape with natural uncoiling force and a 50% overlap. Make sure to cover the head and the tail of the connector.

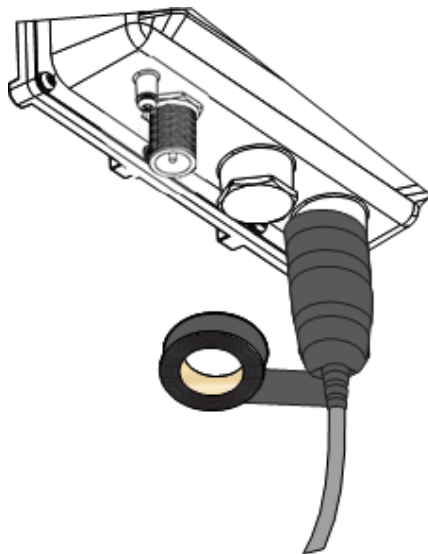

Figure 13: Final PVC wrapping

WisGate Developer D4+ (RAK7244C) Outdoor Case Quick Assembly Guide

In this guide, the process of assembling and mounting an outdoor case for the RAK7244C WisGate Developer D4+ will be shown step by step. Strict adherence to the steps guarantees a secured and durable outdoor casing.

Kit Inclusion

The package includes all the necessary parts for this project, without the RAK7244C WisGate Developer D4+ itself.

1. Outdoor Enclosure Kit
2. PoE splitter Type-C USB (in 48 V; out 5 V/2.4 A)
3. PoE injector (in 100-240 V; out 48 V/0.5 A)
4. Power cord for the PoE Injector
5. Zip tie, PVC tape, and waterproof tape
6. Antenna cable type RG316, with N-type to RP-SMA male connectors for LoRa antenna
7. Antenna cable type RG316, with N-type to SMA male connectors for GPS antenna
8. GPS Antenna with mounting brackets

Assembly

A detailed explanation of the procedure of putting the RAK7244C WisGate Developer D4+ inside the RAKBox-GW-3 is shown.

1. Open the RAKBox-GW-3 enclosure. Remove the top cover and take out the mounting plate.

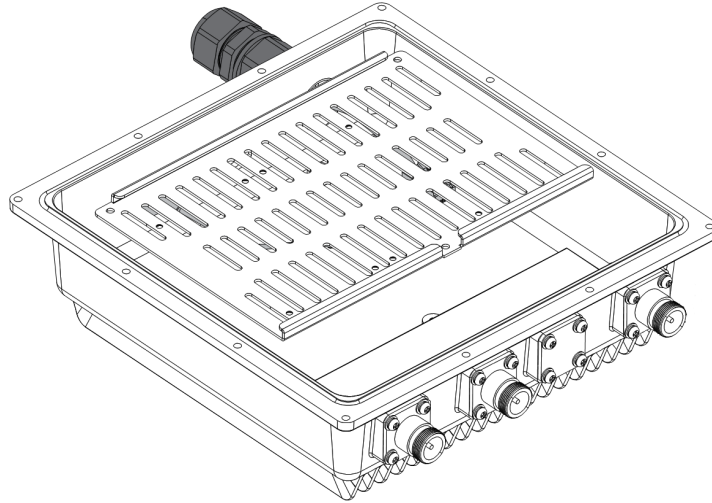

Figure 14: Mounting plate inside the RAKBox-GW-3 enclosure

2. Unscrew the four screws from the bottom cooling plate of the RAK7244 WisGate Developer D4. Do not remove the plate itself.

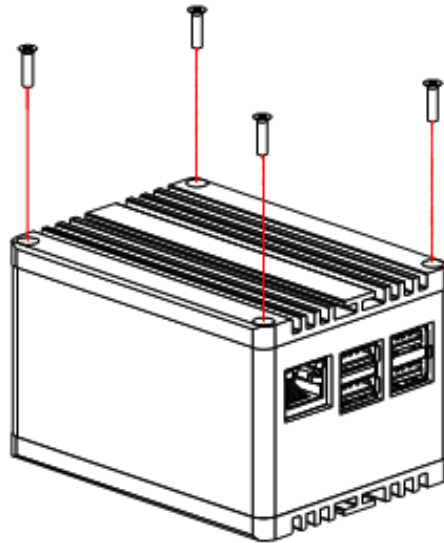

Figure 15: RAK7244C WisGate Developer D4+

3. Align the RAK7244C WisGate Developer D4+ to the proper holes of the mounting plate and fix it together with the previously removed screws.

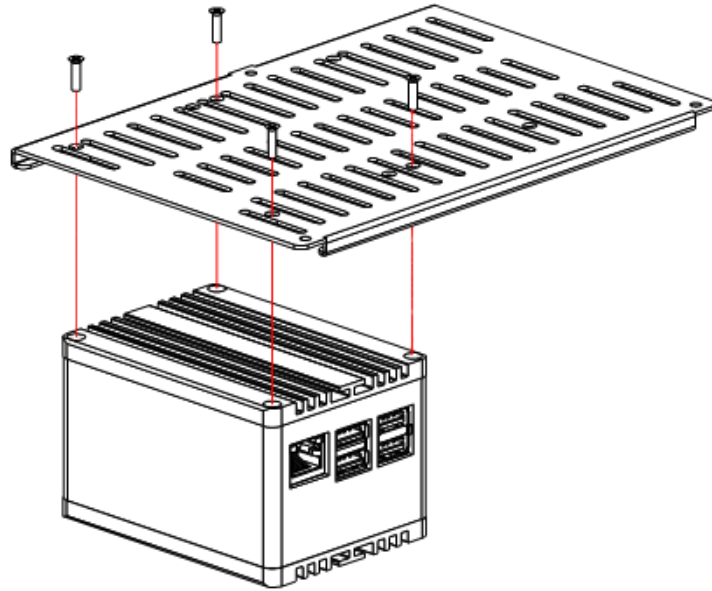

Figure 16: Fixing the RAK7244C WisGate Developer D4+ to the mounting plate

- Place the PoE splitter on the mounting plate and fix it with cable ties. Plug the RJ45 cable and USB type-C cable of the PoE splitter in the corresponding ports of the RAK7244C WisGate Developer D4+.

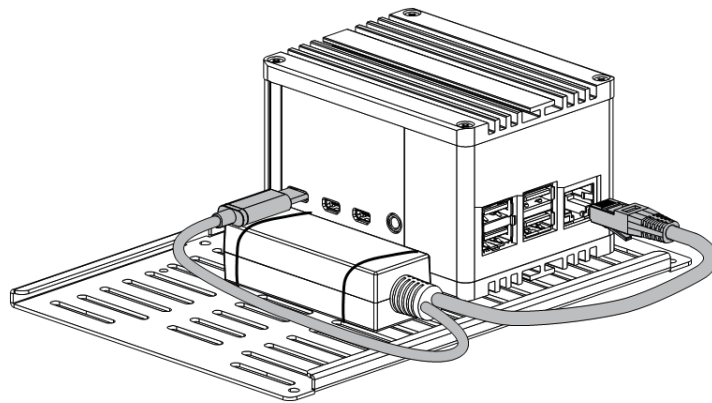

Figure 17: Placing and connection of the PoE Splitter

- Put the mounting plate with the secured RAK7244C WisGate Developer D4+ and PoE splitter back in the enclosure. Fix the plate with the screws.

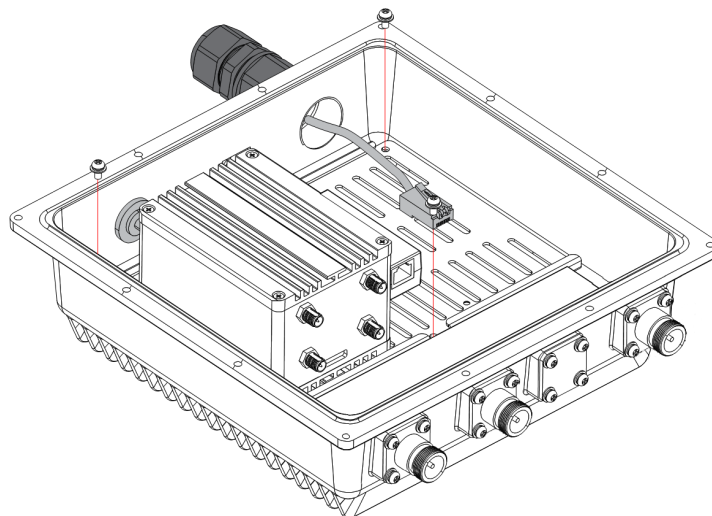

Figure 18: Fixing the mounting plate inside the enclosure

- Plug the RJ45 Network cable coming out from the cable gland to the PoE splitters RJ45 port. Connect the RP-SMA male antenna connector of the enclosure to the RP-SMA female antenna connector of the RAK7244C WisGate Developer D4+. Connect the SMA male GPS antenna connector of the enclosure to SMA female antenna connector of the RAK7244C Gateway. Connect the two RP-SMA male LTE antenna connectors of the enclosure to the two RP-SMA female connectors for the LTE antennas on the RAK7244C WisGate Developer D4+.

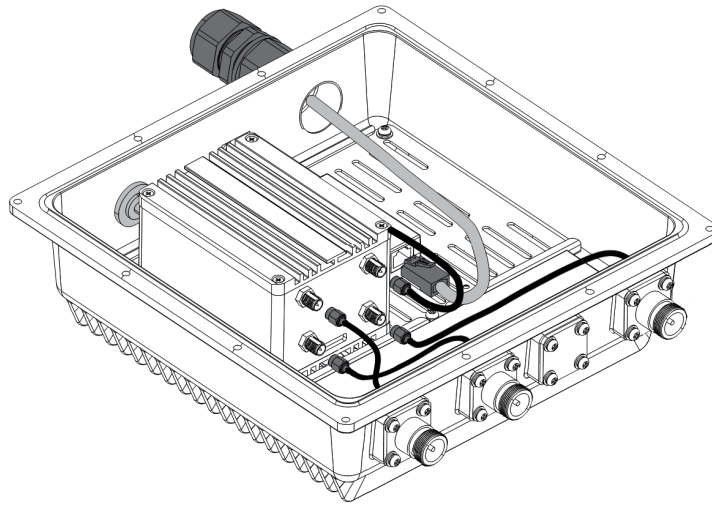

Figure 19: Connecting the network cable and the antennas

7. Close the RAKBox-GW-3's lid and fix it with the screws. Make sure that the rubber seal is placed correctly in the groove between the box and the lid to prevent leaks.

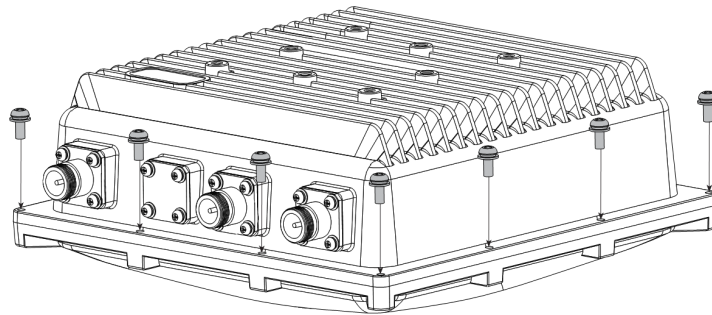

Figure 20: Closing the enclosure

Installation

Instructions on mounting and securing the mounting kit to the enclosure and the bearing pole.

1. Fix the included cross bracket on the bottom of the enclosure with four M6*12 bolts.

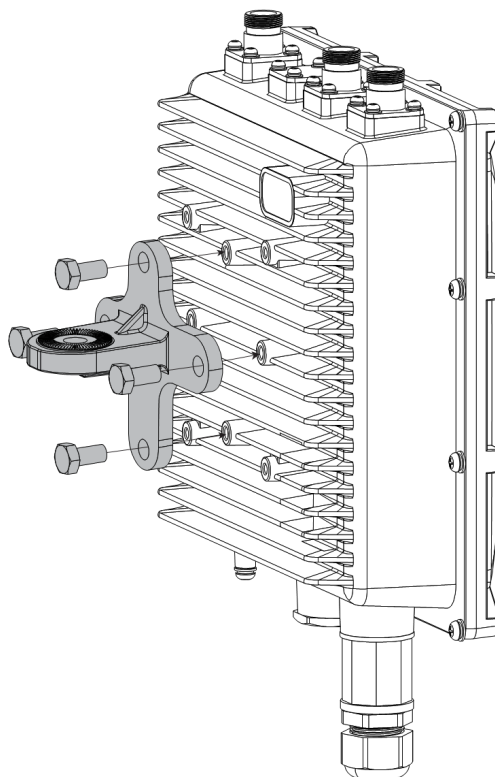

Figure 21: Mounting the cross bracket

2. Place the two pieces of the clamp around the pole and tighten them with the included M6*110 bolts, washers, and nuts.

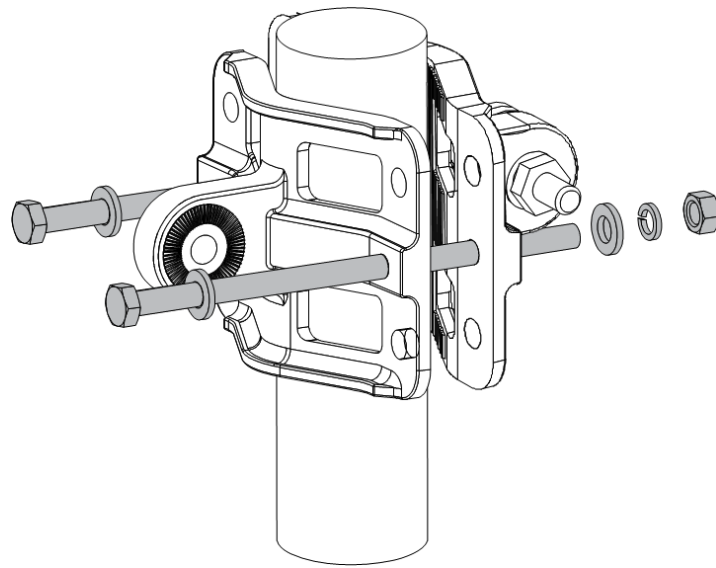

Figure 22: Mounting the clamp to the pole

3. Connect the pole clamp and the cross bracket by securing the last piece of the mounting kit in place using M6*30 bolts, washers, and nuts.

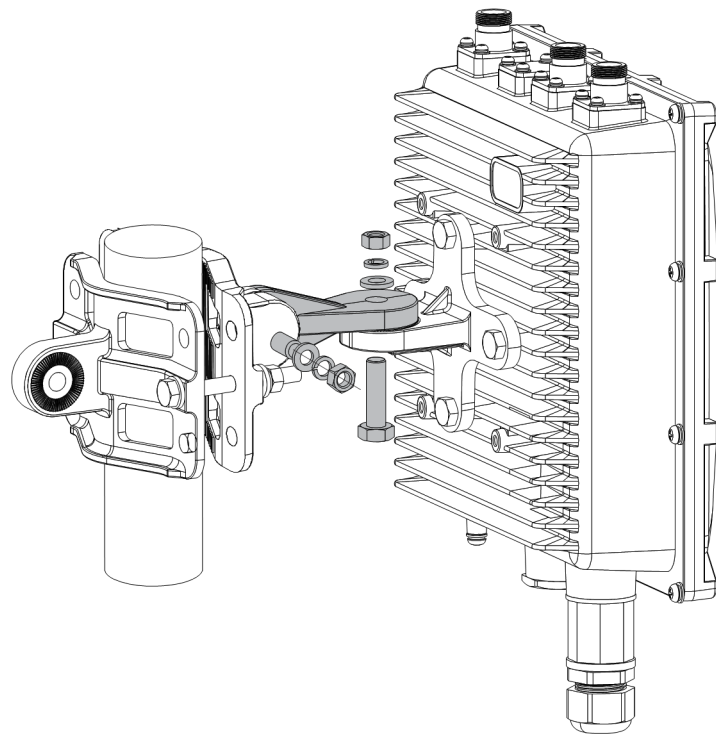

Figure 23: Fixing the enclosure to the pole clamp

Weather Protection

To better protect the Ethernet cable gland and the antenna connector from the weather, you need to cover them with PVC tape.

1. Clean the surface area of the connector that will be wrapped. Wrap a layer of PVC tape with a 50% overlap according to the rotation direction of the connector. Continue wrapping the PVC tape to about 10 mm below the end of the connector.

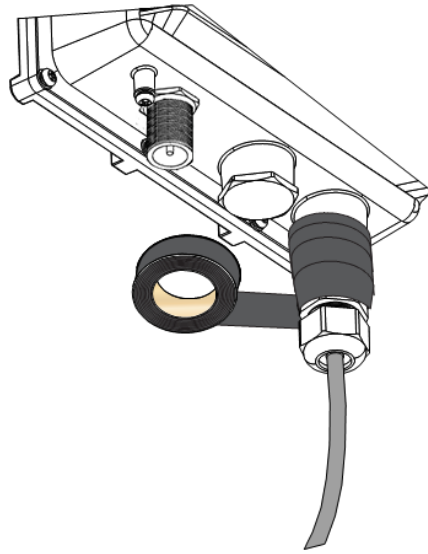

Figure 24: Wrapping with PVC tape

2. Cut off about 50 cm waterproof tape. Stretch it to double the length. Wrap three layers around the connector with a 50% overlap. Hold the tape in place with your hand for a few seconds.

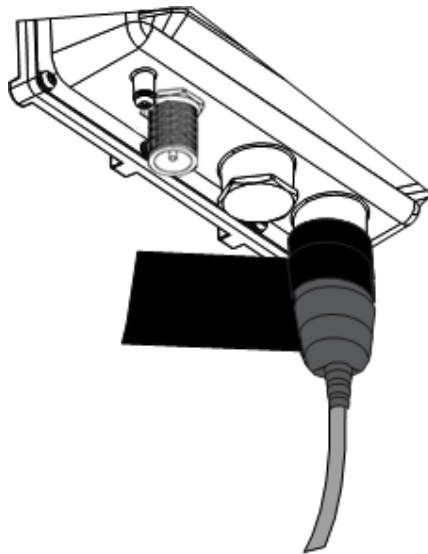

Figure 25: Wrapping with waterproof tape

3. Wrap three additional layers with PVC tape with natural uncoiling force and a 50% overlap. Make sure to cover the head and the tail of the connector.

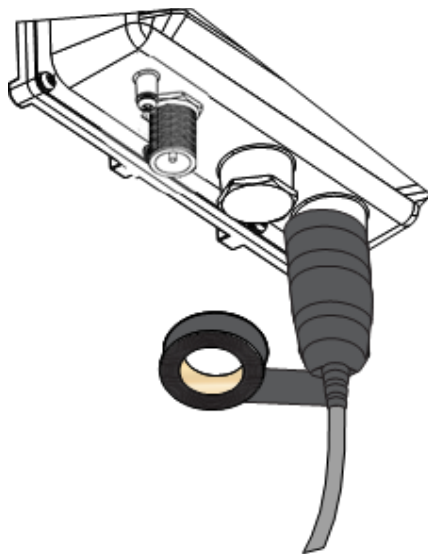

Figure 26: Final PVC wrapping

WisGate Developer D4P (RAK7244P) Outdoor Case Quick Assembly Guide

In this guide, the process of assembling and mounting an outdoor case for the RAK7244P WisGate Developer D4P will be shown step by step. Strict adherence to the steps guarantees a secured and durable outdoor casing.

Kit Inclusion

The package includes all the necessary parts for this project, without the RAK7244P WisGate Developer D4P itself.

1. Outdoor Enclosure Kit
2. PoE injector (in 100-240 V; out 48 V/0.5 A)
3. Power cord for the PoE Injector
4. Zip tie, PVC tape, and waterproof tape
5. Antenna cable type RG316, with N-type to RP-SMA male connectors for LoRa antenna
6. Antenna cable type RG316, with N-type to SMA male connectors for GPS antenna
7. GPS Antenna with mounting bracket

Assembly

A detailed explanation of the procedure of putting the RAK7244P WisGate Developer D4P inside the RAKBox-GW-3 is shown.

1. Open the RAKBox-GW-3 enclosure. Remove the top cover and take out the mounting plate.

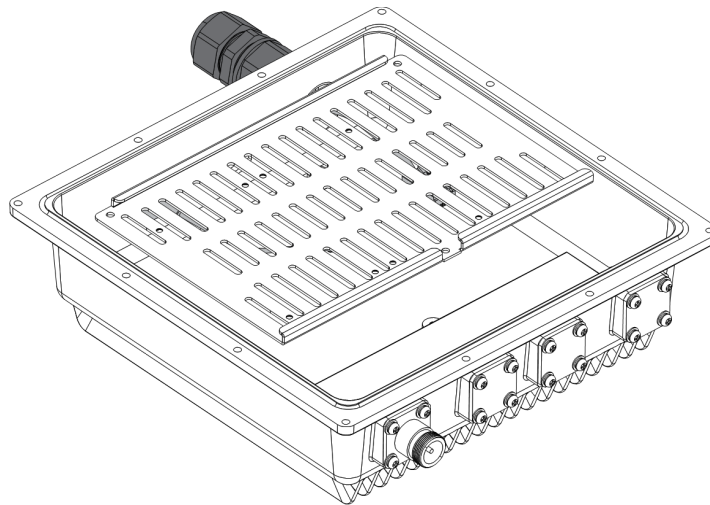

Figure 27: Mounting plate inside the RAKBox-GW-3 enclosure

2. Unscrew the four screws from the bottom cooling plate of the RAK7244P WisGate Developer D4P. Do not remove the plate itself.

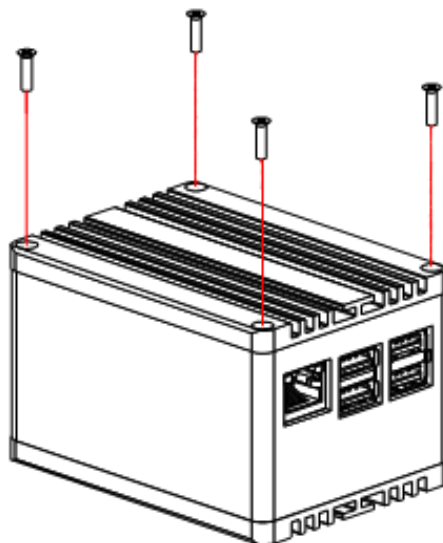

Figure 28: RAK7244P WisGate Developer D4P

- Align the RAK7244P WisGate Developer D4P to the proper holes of the mounting plate and fix it together with the previously removed screws.

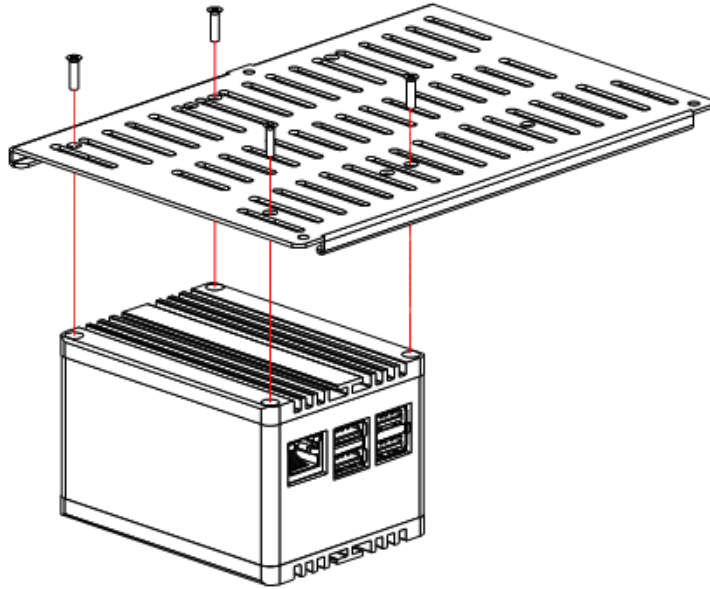

Figure 29: Fixing the RAK7244P WisGate Developer D4P to the mounting plate

- Put the mounting plate with the secured RAK7244P WisGate Developer D4P and PoE splitter back in the enclosure. Fix the plate with the screws.

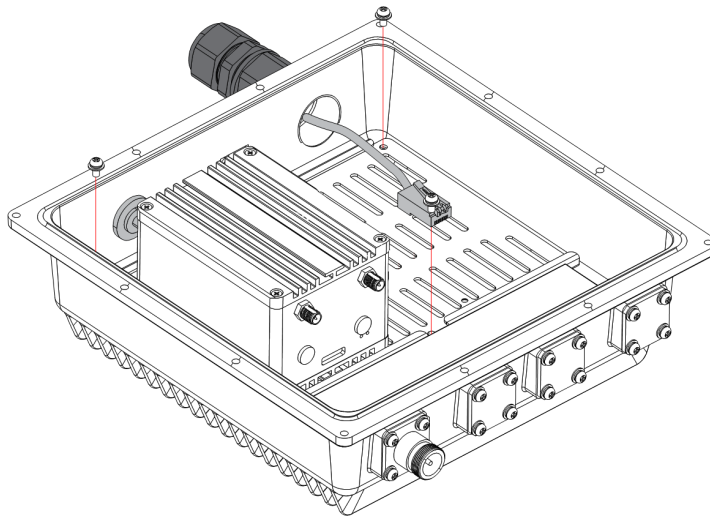

Figure 30: Fixing the mounting plate inside the enclosure

- Plug the RJ45 Network cable coming out from the cable gland to the RJ45 port of the RAK7244P. Connect the RP-SMA male antenna connector of the enclosure to the RP-SMA female antenna connector of the RAK7244P WisGate Developer D4P. Connect the SMA male GPS antenna connector of the enclosure to the SMA female GPS antenna connector of the RAK7244P WisGate Developer D4P.

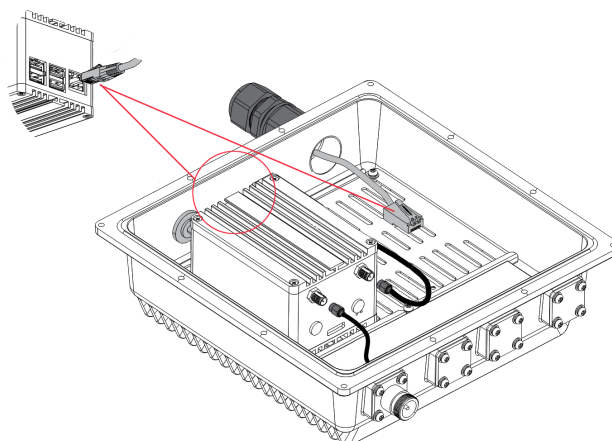

Figure 31: Connecting the network cable and the antennas

- Close the RAKBox-GW-3's lid and fix it with the screws. Make sure that the rubber seal is placed correctly in the groove between the box and the lid to prevent leaks.

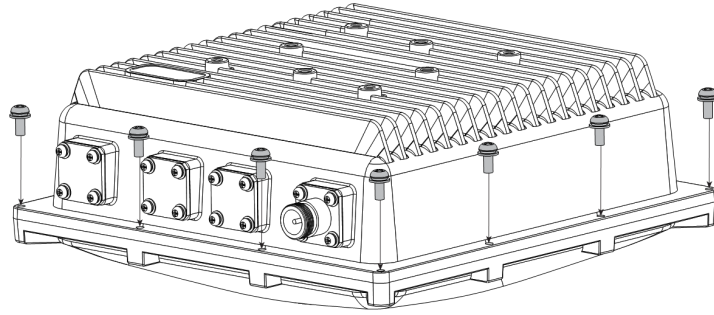

Figure 32: Closing the enclosure

Installation

Instructions on mounting and securing the mounting kit to the enclosure and the bearing pole.

1. Fix the included cross bracket on the bottom of the enclosure with four M6*12 bolts.

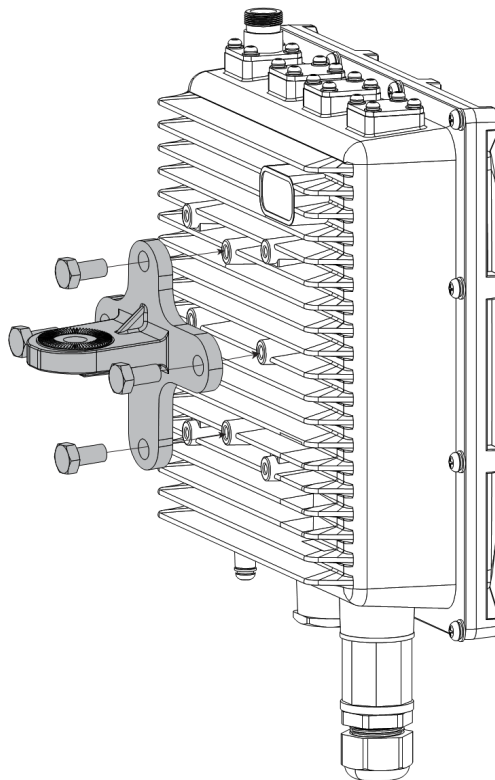

Figure 33: Mounting the cross bracket

2. Place two pieces of the clamp around the pole and tighten them with the included M6*110 bolts, washers, and nuts.

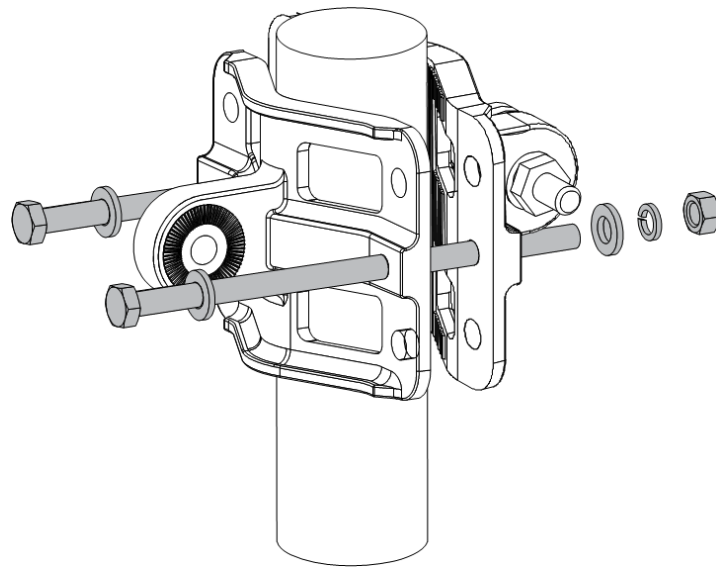

Figure 34: Mounting the clamp to the pole

3. Connect the pole clamp and the cross bracket by securing the last piece of the mounting kit in place using M6*30 bolts, washers, and nuts.

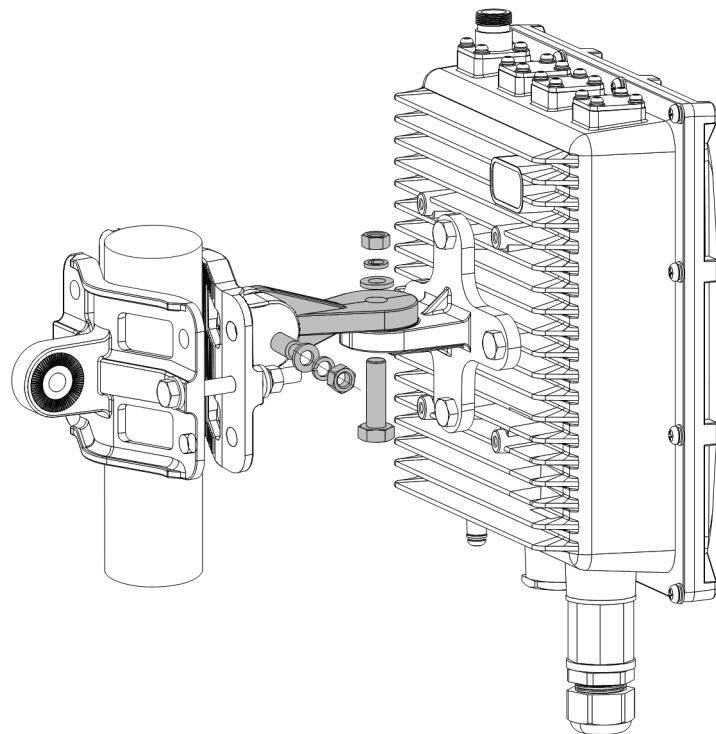

Figure 35: Fixing the enclosure to the pole clamp

Weather Protection

To better protect the Ethernet cable gland and the antenna connector from the weather, you need to cover them with PVC tape.

1. Clean the surface area of the connector that will be wrapped. Wrap a layer of PVC tape with a 50% overlap according to the rotation direction of the connector. Continue wrapping the PVC tape to about 10 mm below the end of the connector.

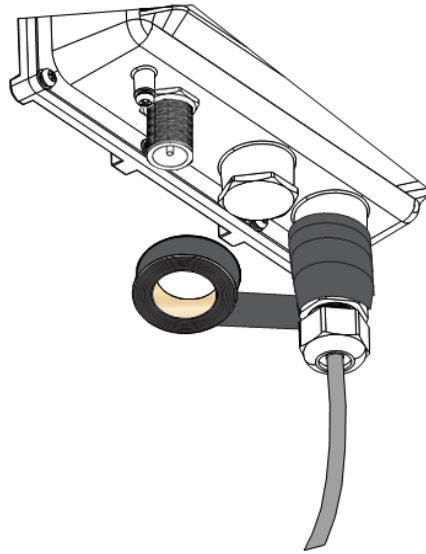

Figure 36: Wrapping with PVC tape

2. Cut off about 50 cm waterproof tape. Stretch it to double the length. Wrap three layers around the connector with a 50% overlap. Hold the tape in place with your hand for a few seconds.

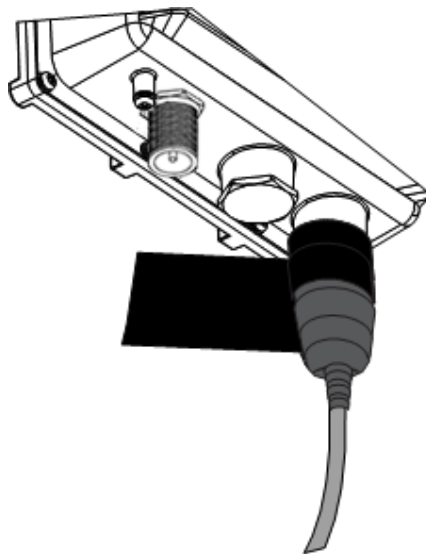

Figure 37: Wrapping with waterproof tape

3. Wrap three additional layers with PVC tape with natural uncoiling force and a 50% overlap. Make sure to cover the head and the tail of the connector.

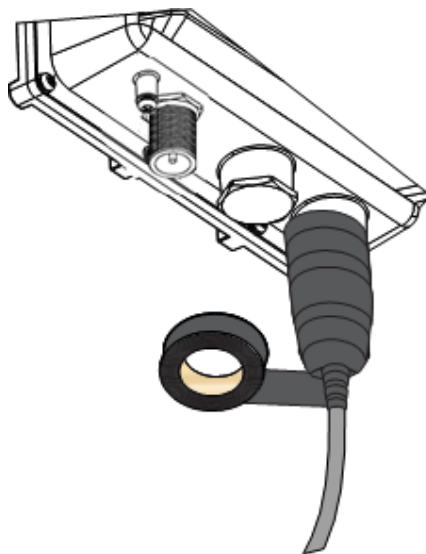

Figure 38: Final PVC wrapping