



# Product Specification Sheet

**Model No: CG0802512HB2-3Y**

<b>Dimensions</b>	80x80x25mm
<b>Bearing System</b>	Dual Ball Bearing
<b>Wire Option</b>	3 Wire with Tachometer, Length - 762mm (30in)
<b>Connector Option</b>	3-Pin 2510 MOLEX (Female Housing/Male Pin)
<b>Rated Voltage</b>	12 VDC
<b>Operating Voltage</b>	4.9V DC - 13.8V DC
<b>Rated Operating Current</b>	0.13 Amp running
<b>Rated Speed</b>	3500 ±10% RPM
<b>Air Flow</b>	43 CFM
<b>Static Air Pressure</b>	8.14 mmH <sub>2</sub> O
<b>Noise Level</b>	28 dBA
<b>Motor Protection Type</b>	By Impedance With Polarity Protection
<b>Environmental Protection</b>	None
<b>Life Expectance</b>	67,000 Hours at 25°C
<b>Operation Temperature</b>	-10°C to +70°C
<b>Net Weight</b>	66g
<b>Options</b>	Closed Corners

# DIMENSIONS DRAWING

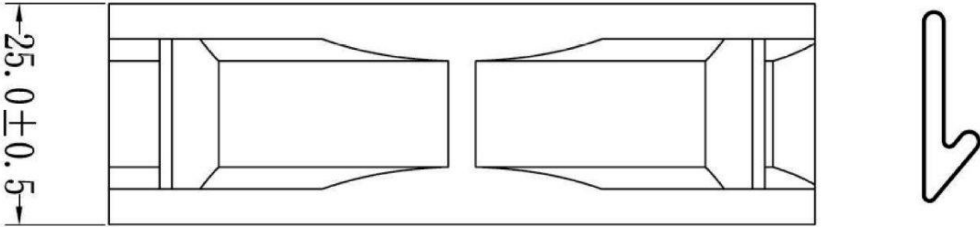
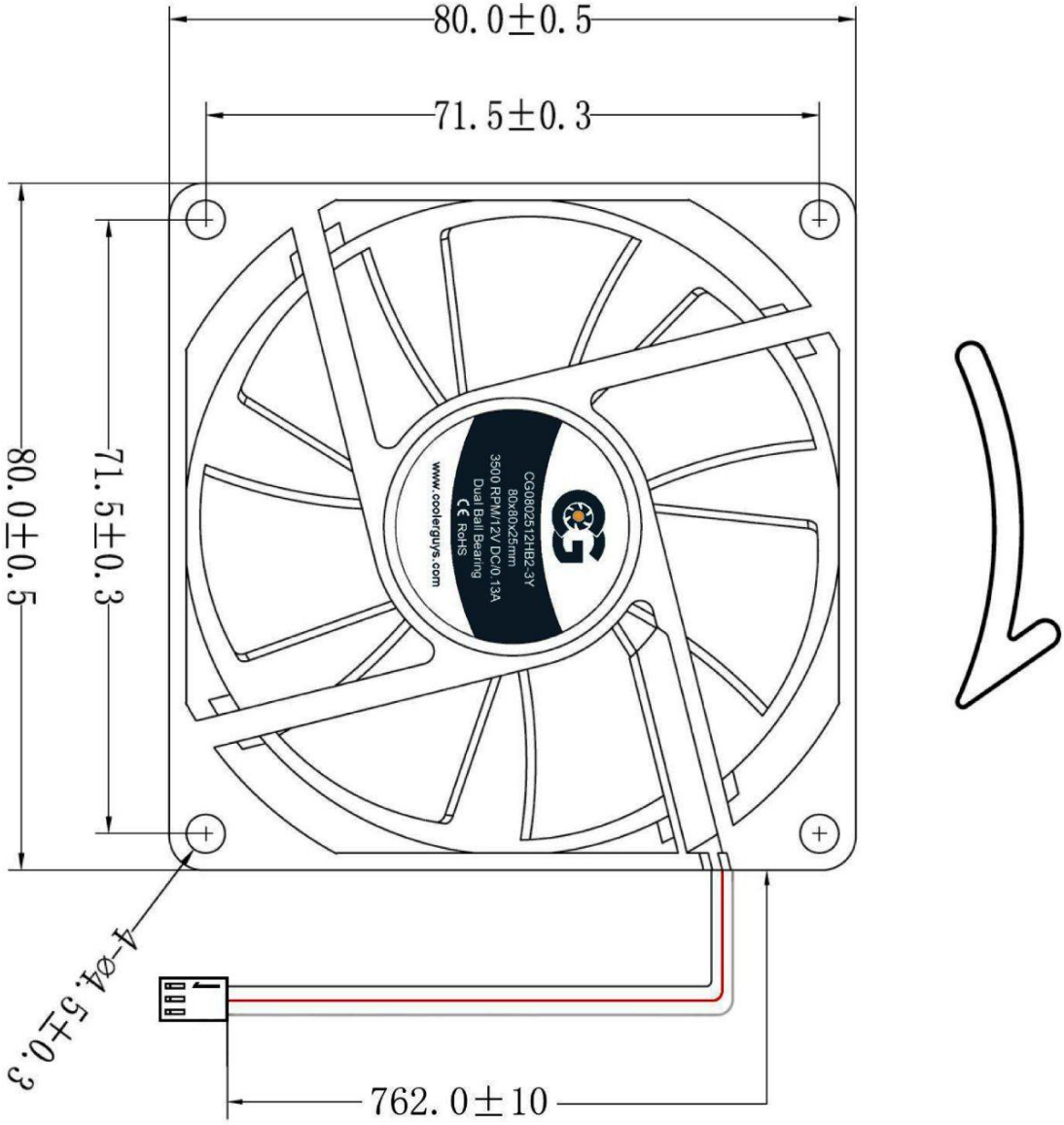

Disclaimer: Blade design may vary.