

6

5

4

3

2

1

D

D

C

C

B

B

A

A

ITEM NO.	SKU	TITLE	DESCRIPTION	QTY.
1	840556091929	COOLERGUY'S 120X120X25MM 12 VDC 3PIN LOW SPEED FAN CG12025L12B2-3Y	COOLERGUY'S 120X120X25MM 12 VDC 3PIN LOW SPEED FAN	2
2			2510 MOLEX 3 PIN CONNECTOR	2
3			3 WIRE WITH TACHOMETER, LENGTH - 762MM(30IN)	2
4	840556074236	COOLERGUY'S 13W DUAL 300X140MM MONOCRYSTALLINE SOLAR PANELS, WITH DUAL 150cm SWITCH WIRE AND 12V OUTPUT WITH BARREL 2.1 X 5.5mm CONNECTOR.	COOLERGUY'S 13W DUAL 300X140MM MONOCRYSTALLINE SOLAR PANELS	1
5			22AWG PARALLEL DC5521 MALE CABLE 150CM	1
6			ON/OFF SWITCH	1
7			WIRE SWITCH	1
8			5.5 X 2.1MM MALE BARREL CONNECTOR	1
9	840556082613	DUAL 120MM BRACKET ACRYLIC COATING	DUAL 120MM BRACKET ACRYLIC COATING	1
10	840556082705	120MM BLACK FAN FINGER GRILL	120MM BLACK FAN FINGER GRILL	4
11	840556100348	(1-4 PACKS) BOLTS (MACHINE SCREW) 40MM AND NUTS M4 (4 PACKS)	(1 - 4 PACKS) BOLTS (MACHINE SCREW) 40MM AND NUTS M4	2
12			M4 NUT	
13	840556071686	BARREL (2.1MM X 5.5MM) FEMALE BARREL TO 3PIN FAN ADAPTER DUAL SPLITTER	2.1MMX5.5MM FEMALE BARREL CONNECTOR	1
14			STANDARD 3 PIN FAN CONNECTOR	2
15			150MM(6IN) WIRE	2
16	840556092575	BLACK MOUNTING SCREWS FOR CABINET BRACKET: #6-13 X 5/8"	BLACK MOUNTING SCREWS FOR CABINET BRACKET: #6-13 X 5/8"	4

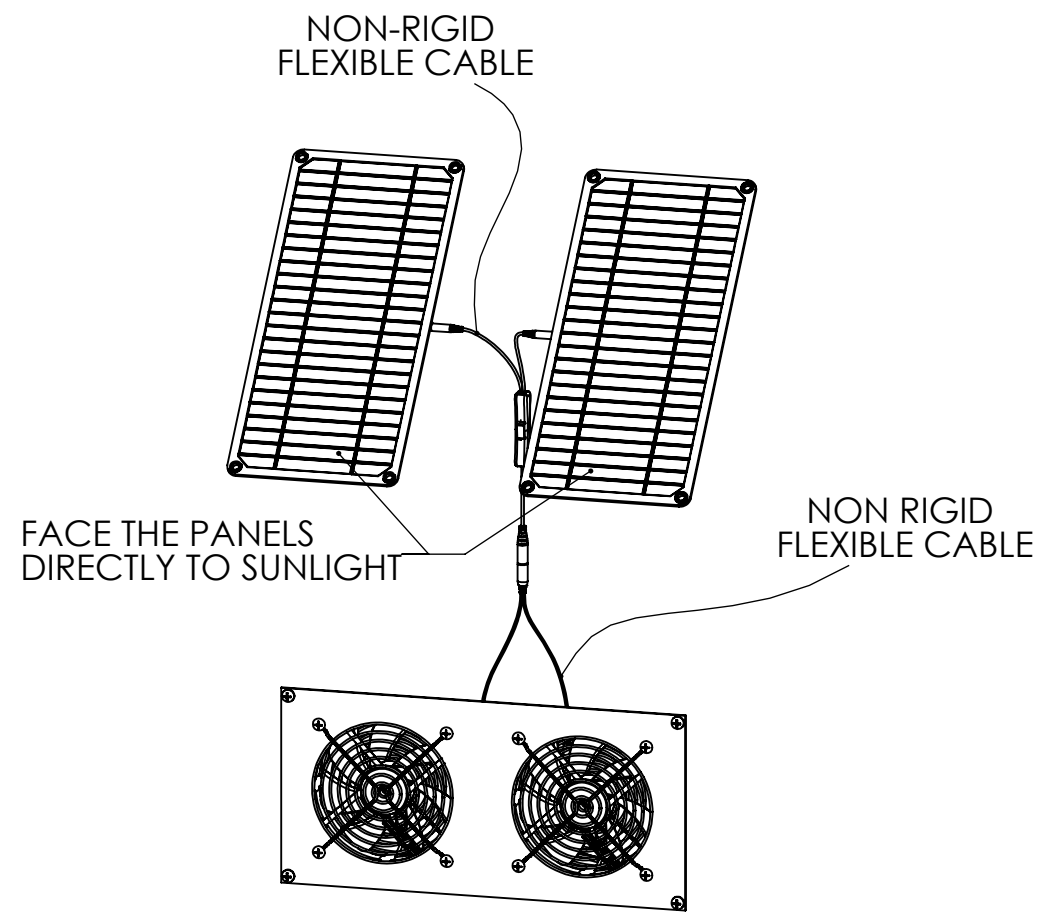

CG12025L12B2-3Y 840556091929 FAN SPECIFICATIONS		SOLAR PANEL SPECIFICATIONS	
DIMENSIONS:	120X120X25MM	SOLAR PANEL SIZE	300X140X2.5mm
BEARING SYSTEM:	DUAL BALL BEARING	SOLAR CELL TYPE	MONOCRYSTALLINE
WIRE OPTION:	3 WIRE WITH TACHOMETER, LENGTH - 762MM (30IN)	SOLAR CELL EFFICIENCY	20.50%
CONNECTOR OPTION:	3PIN 2510 MOLEX (FEMALE HOUSING/MALE PIN)	MAXIMUM POWER (P _{MAX})	6.5W
RATED VOLTAGE:	12 VDC	MAXIMUM POWER CURRENT (I _{MPP})	0.5A
OPERATING VOLTAGE:	4.9 VDC - 13.8 VDC	OPTIMUM OPERATING VOLTAGE (V _{MP})	12.4 VDC
RATED OPERATING CURRENT:	0.06 AMP RUNNING	OPEN-CIRCUIT VOLTAGE (V _{OC})	14.4 VDC
RATED SPEED:	1200 ±10% RPM	SHORT-CIRCUIT CURRENT (I _{SC})	0.48A
AIR FLOW:	90 CFM (COMBINED)	DUAL SOLAR PANEL WORKING TEMPERATURE	13W, 12 VDC, 1A (MAX) -40°C TO +85°C
STATIC AIR PRESSURE:	1.16 MMH ₂ O	JUNCTION BOX RATING	≥IP66
NOISE LEVEL:	23.4 DBA (COMBINED)	DUAL SOLAR PANEL WEIGHT	0.375KG
MOTOR PROTECTION TYPE:	BY IMPEDANCE WITH POLARITY PROTECTION	CABLE SPEC	22AWG DC5221 MALE CABLE, USE THE 304 SWITCH. 150CM
ENVIRONMENTAL PROTECTION:	NONE		
LIFE EXPECTANCE:	67,000 HOURS AT 25°C		
OPERATION TEMPERATURE:	-10α TO +65α		
NET WEIGHT:	274G		
OPTIONS:	OPEN CORNERS		

COOLERGUY'S

COOLERGUY'S SOLAR POWERED DUAL FAN COOLING KIT

SKU: 840556072232	A4
SCALE: NTS	SHEET 1 OF 4

6

5

4

3

2

1

6 5 4 3 2 1

D

C

B

A

D

C

B

A

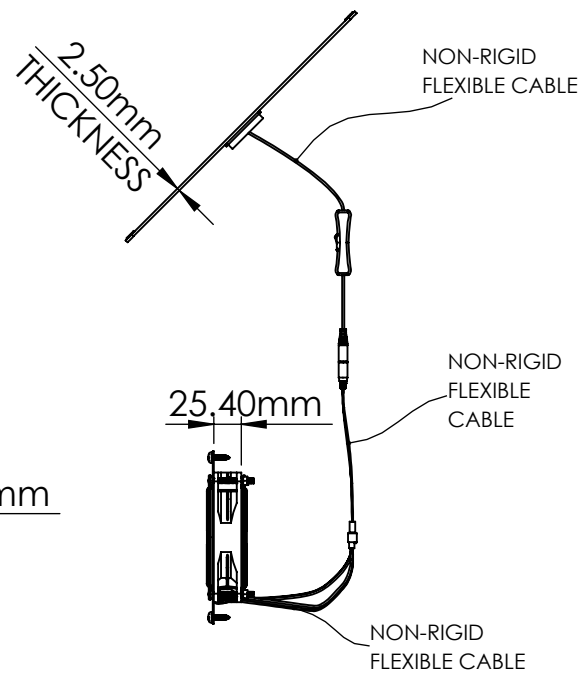
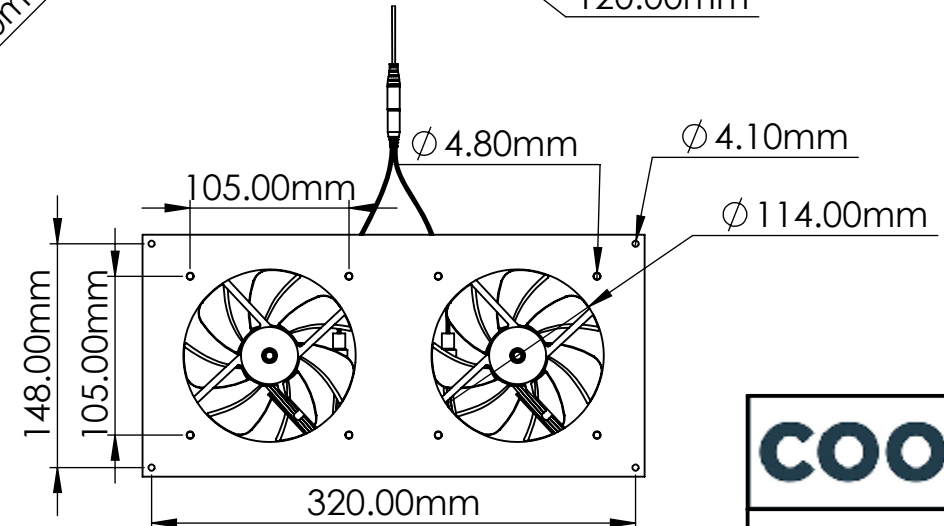
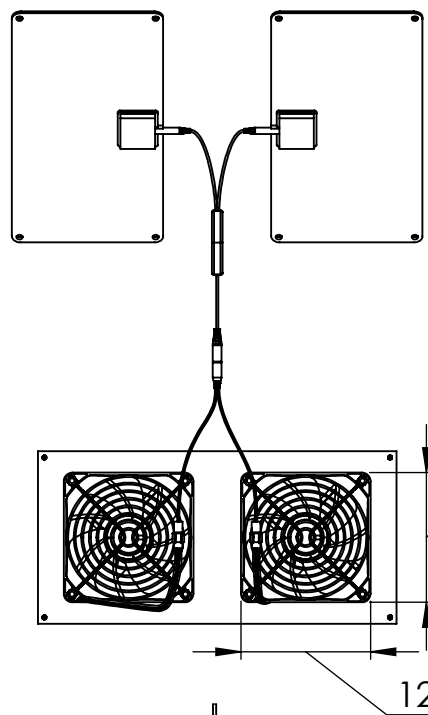
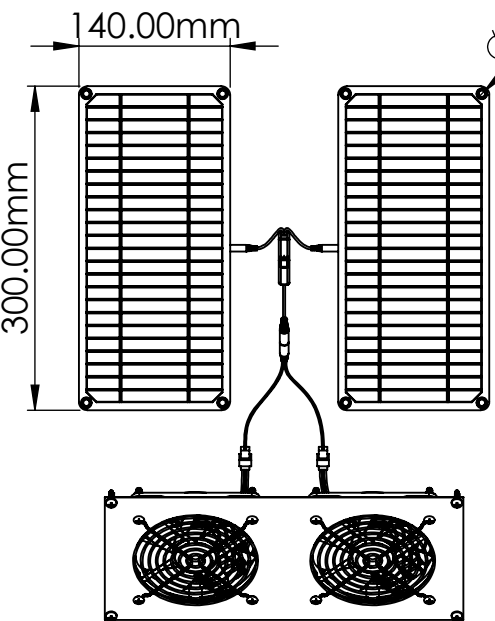
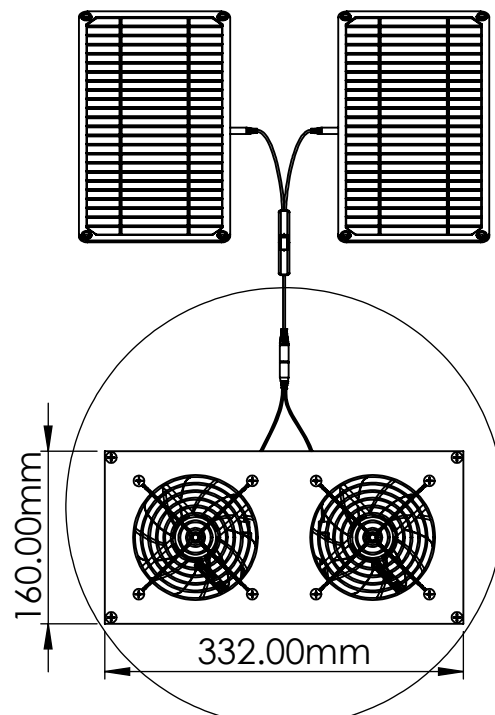

COOLERGUYS	
COOLERGUYS SOLAR POWERED DUAL FAN COOLING KIT	
SKU: 840556072232	A4
SCALE: NTS	SHEET 2 OF 4

6 5 4 3 2 1

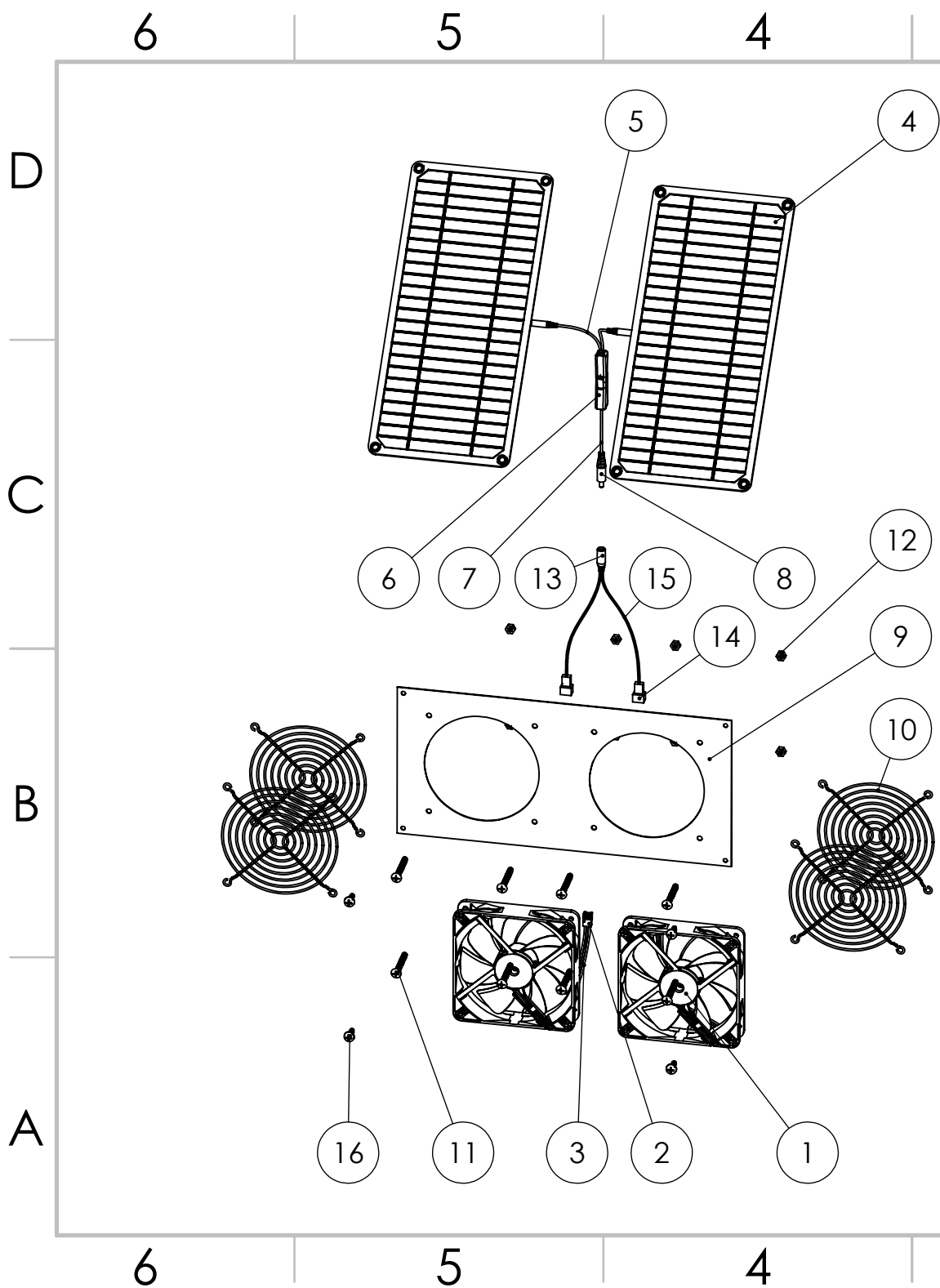

ITEM NO.	SKU	TITLE	DESCRIPTION	QTY.		
1	840556091929	COOLERGUYS 120X120X25MM 12 VDC 3PIN LOW SPEED FAN CG12025L12B2-3Y	COOLERGUYS 120X120X25MM 12 VDC 3PIN LOW SPEED FAN	2		
2			2510 MOLEX 3 PIN CONNECTOR	2		
3			3 WIRE WITH TACHOMETER, LENGTH - 762MM(30IN)	2		
4	840556074236	COOLERGUYS 13W DUAL 300X140MM MONOCRYSTALLINE SOLAR PANELS, WITH DUAL 150cm SWITCH WIRE AND 12V OUTPUT WITH BARREL 2.1 X 5.5mm CONNECTOR.	COOLERGUYS 13W DUAL 300X140MM MONOCRYSTALLINE SOLAR PANELS	1		
5			22AWG PARALLEL DC5521 MALE CABLE 150CM	1		
6			ON/OFF SWITCH	1		
7			WIRE SWITCH	1		
8			5.5 X 2.1MM MALE BARREL CONNECTOR	1		
9			840556082613	DUAL 120MM BRACKET ACRYLIC COATING	DUAL 120MM BRACKET ACRYLIC COATING	1
10			840556082705	120MM BLACK FAN FINGER GRILL	120MM BLACK FAN FINGER GRILL	4
11			840556100348	(1-4 PACKS) BOLTS (MACHINE SCREW) 40MM AND NUTS M4 (4 PACKS)	(1 - 4 PACKS) BOLTS (MACHINE SCREW) 40MM AND NUTS M4	2
12	M4 NUT					
13	840556071686	BARREL (2.1MM X 5.5MM) FEMALE BARREL TO 3PIN FAN ADAPTER DUAL SPLITTER	2.1MMX5.5MM FEMALE BARREL CONNECTOR	1		
14			STANDARD 3 PIN FAN CONNECTOR	2		
15			150MM(6IN) WIRE	2		
16	840556092575	BLACK MOUNTING SCREWS FOR CABINET BRACKET: #6-13 X 5/8"	BLACK MOUNTING SCREWS FOR CABINET BRACKET: #6-13 X 5/8"	4		

COOLERGUYS

COOLERGUYS SOLAR POWERED DUAL FAN COOLING KIT

SKU: 840556072232 A4

SCALE: NTS SHEET 3 OF 4

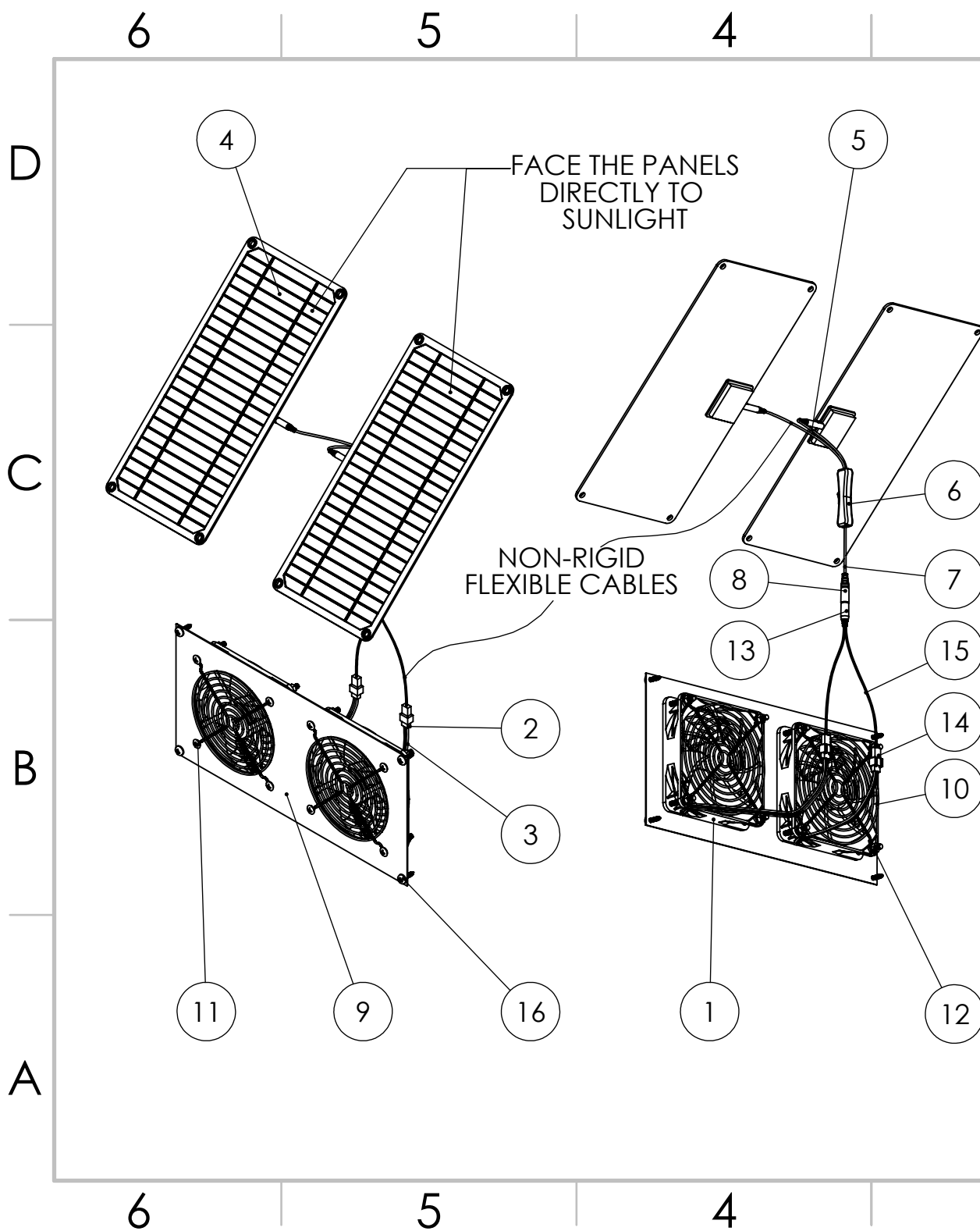

ITEM NO.	SKU	TITLE	DESCRIPTION	QTY.
1	840556091929	COOLERGUY'S 120X120X25MM 12 VDC 3PIN LOW SPEED FAN CG12025L12B2-3Y	COOLERGUY'S 120X120X25MM 12 VDC 3PIN LOW SPEED FAN	2
2			2510 MOLEX 3 PIN CONNECTOR	2
3			3 WIRE WITH TACHOMETER, LENGTH - 762MM(30IN)	2
4	840556074236	COOLERGUY'S 13W DUAL 300X140MM MONOCRYSTALLINE SOLAR PANELS, WITH DUAL 150cm SWITCH WIRE AND 12V OUTPUT WITH BARREL 2.1 X 5.5mm CONNECTOR.	COOLERGUY'S 13W DUAL 300X140MM MONOCRYSTALLINE SOLAR PANELS	1
5			22AWG PARALLEL DC5521 MALE CABLE 150CM	1
6			ON/OFF SWITCH	1
7			WIRE SWITCH	1
8			5.5 X 2.1MM MALE BARREL CONNECTOR	1
9	840556082613	DUAL 120MM BRACKET ACRYLIC COATING	DUAL 120MM BRACKET ACRYLIC COATING	1
10	840556082705	120MM BLACK FAN FINGER GRILL	120MM BLACK FAN FINGER GRILL	4
11	840556100348	(1-4 PACKS) BOLTS (MACHINE SCREW) 40MM AND NUTS M4 (4 PACKS)	(1 - 4 PACKS) BOLTS (MACHINE SCREW) 40MM AND NUTS M4	2
12			M4 NUT	
13	840556071686	BARREL (2.1MM X 5.5MM) FEMALE BARREL TO 3PIN FAN ADAPTER DUAL SPLITTER	2.1MMX5.5MM FEMALE BARREL CONNECTOR	1
14			STANDARD 3 PIN FAN CONNECTOR	2
15			150MM(6IN) WIRE	2
16	840556092575	BLACK MOUNTING SCREWS FOR CABINET BRACKET: #6-13 X 5/8"	BLACK MOUNTING SCREWS FOR CABINET BRACKET: #6-13 X 5/8"	4

COOLERGUY'S

COOLERGUY'S SOLAR POWERED DUAL FAN COOLING KIT

SKU: 840556072232

A4

SCALE: NTS

SHEET 4 OF 4