

ITEM NO.	SKU	TITLE	DESCRIPTION	QTY.
1	840556092049	COOLERGUY'S 80X80X25MM ULTRA QUIET DUAL BALL 12 VOLT FAN FAN MEDIUM SPEED	80X80X25MM WITH MEDIUM SPEED OF FAN MODEL	1
2			3 WIRE WITH TACHOMETER, LENGTH - 762MM(30IN)	
3			3-PIN 2510 MOLEX (FEMALE HOUSING/MALE PIN) CONNECTOR	
4	840556094500	COOLERGUY'S SINGLE 80mm FAN BRACKET BLACK POWDER COATED METAL	BLACK POWDER COATING METAL BRACKET FOR 80mm FANS	1
5	840556082897	80mm BLACK FAN GRILL	BLACK FAN GRILL FOR 80mm FANS	2
6	840556072294	COOLERGUY'S FAN POWER SUPPLY 100-240V AC TO 12V DC 1A OUTPUT 3PIN OR 4PIN PWM CONNECTOR	COOLERGUY'S FAN POWER SUPPLY 100-240V AC TO 12V DC 1A OUTPUT 3PIN OR 4PIN PWM CONNECTOR	1
7			STANDARD 3PIN OR 4PIN CONNECTOR	1
8			1.5M(60IN) LEAD CABLE	1
9	840556100348	(1 - 4 PACKS) BOLTS(MACHINE SCREW) 40MM AND NUTS M4	BOLTS(MACHINE SCREW) 40MM	1
10			M4 NUT	
11	840556092575	BLACK WOOD SCREWS M3.5 *12m	MOUNTING SCREWS FOR BRACKET	4

CG08025M12B2-3Y 840556092049

DIMENSIONS:	80X80X25MM
BEARING SYSTEM:	DUAL BALL BEARING
WIRE OPTION:	3 WIRE WITH TACHOMETER, LENGTH - 762MM (30IN)
CONNECTOR OPTION:	3PIN 2510 MOLEX (FEMALE HOUSING/MALE PIN)
RATED VOLTAGE:	12 VDC
OPERATING VOLTAGE:	4.9 VDC - 13.8 VDC
RATED OPERATING CURRENT:	0.05 AMP RUNNING
RATED SPEED:	2500 ±10% RPM
AIR FLOW:	32 CFM
STATIC AIR PRESSURE:	3.89 MMH2O
NOISE LEVEL:	23 DBA
MOTOR PROTECTION TYPE:	BY IMPEDANCE WITH POLARITY PROTECTION
ENVIRONMENTAL PROTECTION:	NONE
LIFE EXPECTANCE:	67,000 HOURS AT 25°C
OPERATION TEMPERATURE:	-10°C TO + 70°C
NET WEIGHT:	66G
OPTIONS:	CLOSED CORNERS

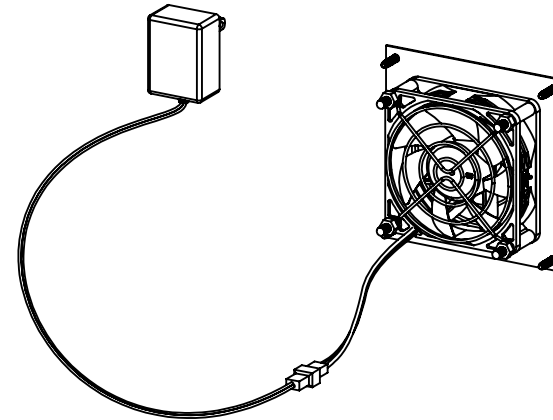
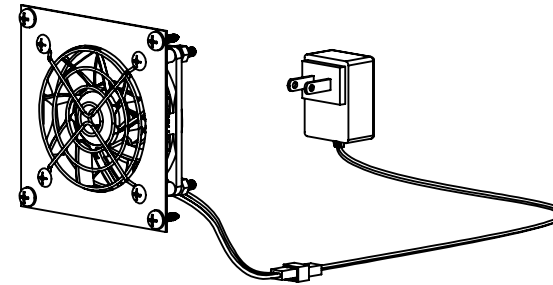

COOLERGUY'S

COOLERGUY'S SINGLE 80MM FAN
COOLING KIT - METAL BRACKET

SKU: 840556002406

A4

SCALE: NTS

SHEET 1 OF 3

6

5

4

3

2

1

D

D

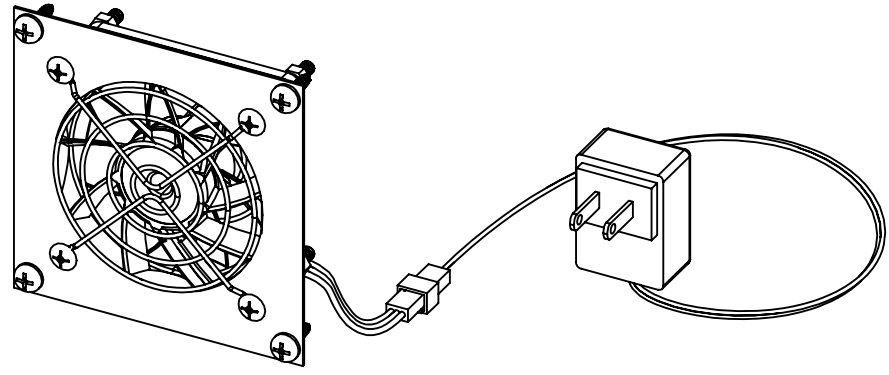
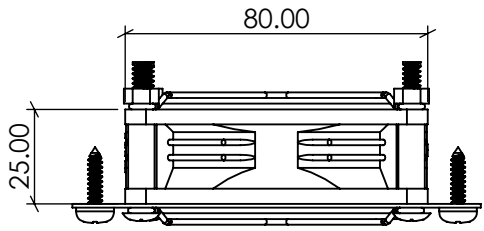

C

C

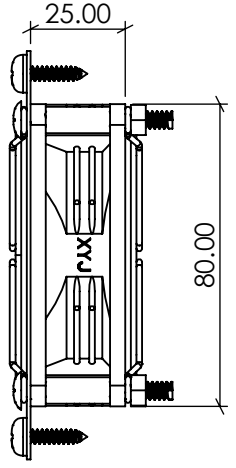
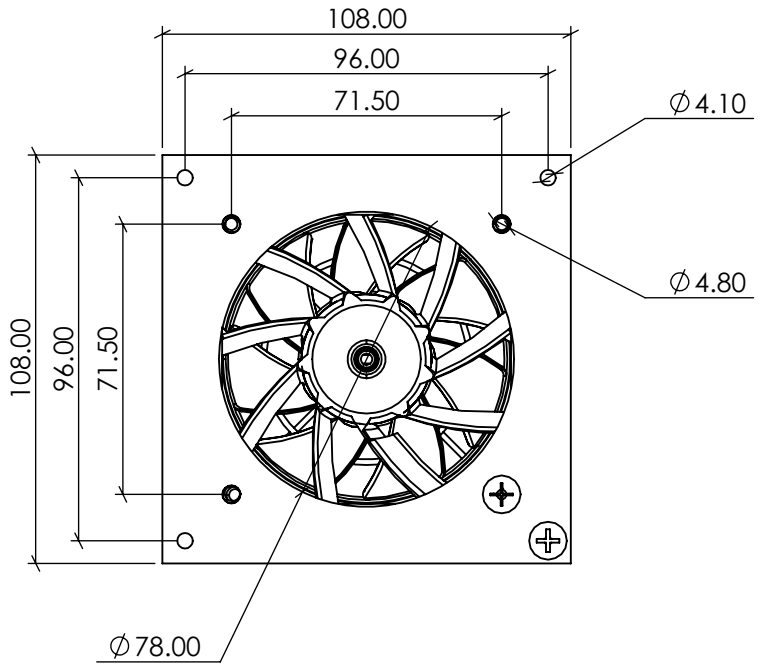

B

B

A

A

COOLERGUY'S

COOLERGUY'S SINGLE 80MM FAN
COOLING KIT - METAL BRACKET

SKU: 840556002406	A4
SCALE: NTS	SHEET 2 OF 3

6

5

4

3

2

1

ITEM NO.	SKU	TITLE	DESCRIPTION	QTY.
1	840556092049	COOLERGUY'S 80X80X25MM ULTRA QUIET DUAL BALL 12 VOLT FAN FAN MEDIUM SPEED	80X80X25MM WITH MEDIUM SPEED OF FAN MODEL	1
2			3 WIRE WITH TACHOMETER, LENGTH - 762MM(30IN)	
3			3-PIN 2510 MOLEX (FEMALE HOUSING/MALE PIN) CONNECTOR	
4	840556094500	COOLERGUY'S SINGLE 80mm FAN BRACKET BLACK POWDER COATED METAL	BLACK POWDER COATING METAL BRACKET FOR 80mm FANS	1
5	840556082897	80mm BLACK FAN GRILL	BLACK FAN GRILL FOR 80mm FANS	2
6	840556072294	COOLERGUY'S FAN POWER SUPPLY 100-240V AC TO 12V DC 1A OUTPUT 3PIN OR 4PIN PWM CONNECTOR	COOLERGUY'S FAN POWER SUPPLY 100-240V AC TO 12V DC 1A OUTPUT 3PIN OR 4PIN PWM CONNECTOR	1
7			STANDARD 3PIN OR 4PIN CONNECTOR	1
8			1.5M(60IN) LEAD CABLE	1
9	840556100348	(1 - 4 PACKS) BOLTS(MACHINE SCREW) 40MM AND NUTS M4	BOLTS(MACHINE SCREW) 40MM	1
10			M4 NUT	
11	840556092575	BLACK WOOD SCREWS M3.5 *12m	MOUNTING SCREWS FOR BRACKET	4

CG08025M12B2-3Y 840556092049

DIMENSIONS:	80X80X25MM
BEARING SYSTEM:	DUAL BALL BEARING
WIRE OPTION:	3 WIRE WITH TACHOMETER, LENGTH - 762MM (30IN)
CONNECTOR OPTION:	3PIN 2510 MOLEX (FEMALE HOUSING/MALE PIN)
RATED VOLTAGE:	12 VDC
OPERATING VOLTAGE:	4.9 VDC - 13.8 VDC
RATED OPERATING CURRENT:	0.05 AMP RUNNING
RATED SPEED:	2500 ±10% RPM
AIR FLOW:	32 CFM
STATIC AIR PRESSURE:	3.89 MMH2O
NOISE LEVEL:	23 DBA
MOTOR PROTECTION TYPE:	BY IMPEDANCE WITH POLARITY PROTECTION
ENVIRONMENTAL PROTECTION:	NONE
LIFE EXPECTANCE:	67,000 HOURS AT 25°C
OPERATION TEMPERATURE:	-10°C TO + 70°C
NET WEIGHT:	66G
OPTIONS:	CLOSED CORNERS

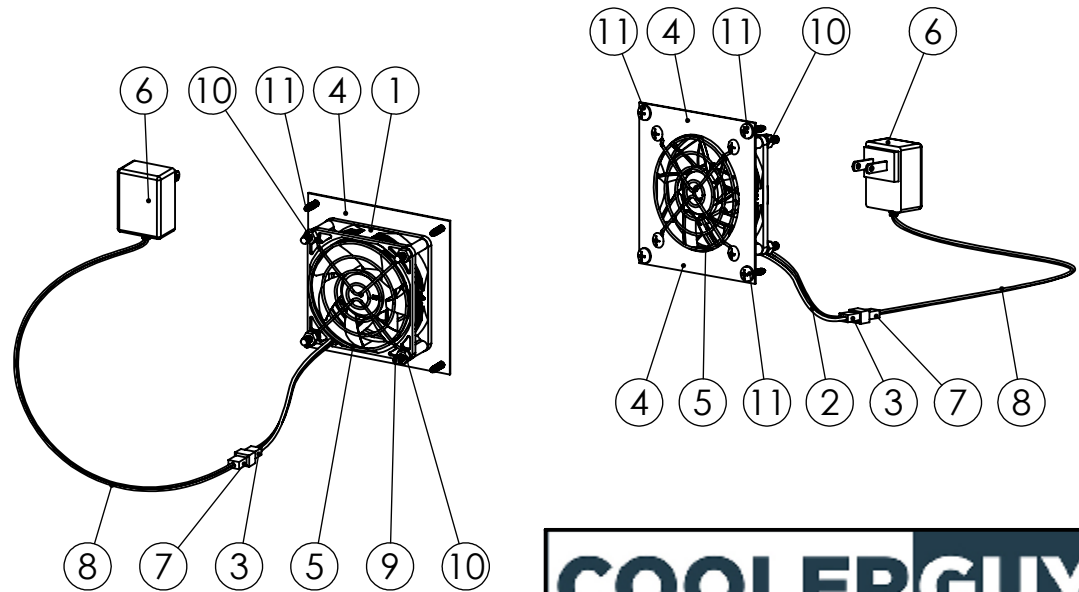
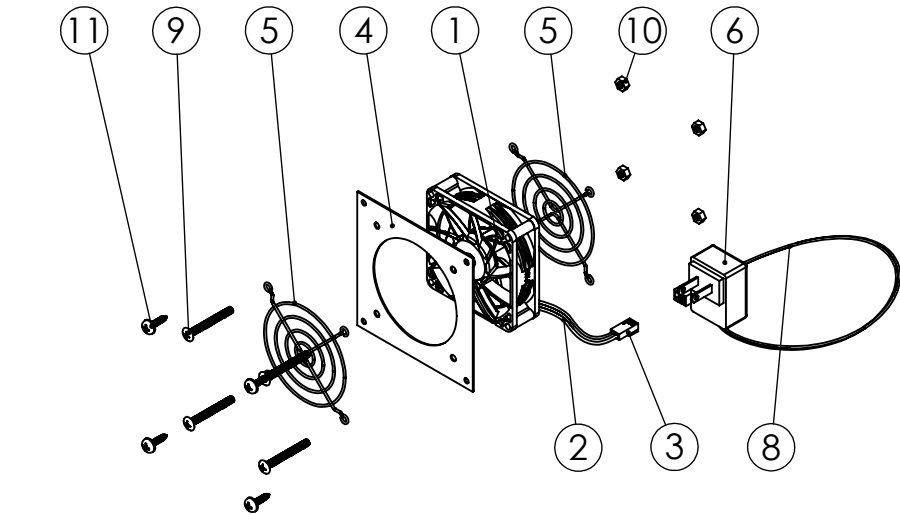

COOLERGUY'S

COOLERGUY'S SINGLE 80MM FAN
COOLING KIT - METAL BRACKET

SKU: 840556002406

A4

SCALE: NTS

SHEET 3 OF 3