



Churrasqueiras e Parrillas



CHARCOAL SUPER³⁵⁰



EXAMPLE PHOTO: 1,50m WIDE SUPER 350
WITH 11 SKEWERS, 3 GALLERIES AND
MANUAL LIFT GRILL.

SCHEER CHURRASQUEIRAS
RUA ROQUE CALLEGE, 133 |
CEP 95041-440 | UNIVERSITÁRIO |
CAXIAS DO SUL | RS | BRAZIL

BRAZIL:
+55 54 3224.3066
SCHEER.COM.BR

UNITED STATES:
+1 954 4152161
SCHEERUSA.COM

JAPAN:
+81 3 3280 1035
KYODAIMARKET.COM

AUSTRALIA:
+61 2 9986 2004
PROLINEEQUIPMENT.COM.AU



FEATURES | BENEFITS

CUSTOMIZED CONSTRUCTION

- Equipment's length customized according to the customer needs from 13 skewers (39 3/8" - 1,00m) up to 50 skewers (78 3/4" - 2m) with 02 or 03 galleries as table below.

LIFT GRILL SYSTEM

- Grilling area located next to the skewers section. It can be equipped with motorized or manual up/down lifting grill system.

HYGIENE

- Equipment coated in brushed stainless steel AISI 304 or AISI 430 (please specify when ordering).

STAINLESS STEEL SKEWERS

- Skewers made with stainless steel blade, zamaq roller and coated aluminum handle.

DOUBLE SPECIAL SCHEER BUSHING

- Special Scheer bushes that does not require oil lubrication.

HIGH QUALITY

- Equipment designed and built with high quality to provide the best results to the final user.

SIMPLE TO USE

- Equipment easy and simple to use.

DRIVE MECHANISM

- Individual gear drives each skewer, skewers next to each other rotate in opposite directions to avoid clipping of meats.

MACHINE STRUCTURE

- Internal tube structure carbon steel;
- 5" casters which helps the displacement for maintenance and cleaning;
- Carbon steel tank SAE 1020 cover with refractory bricks;
- High grade heat insulation under refractory bricks in fire pit saves 20-30% charcoal usage;
- Easy way to remove and maintain the refractory bricks with "T" bar system;
- Two years parts and labor warranty from date of purchase;
- Solid carbon steel bar of 1 1/4" with guide for the gears;
- Cast Iron gears 4"-101mm diameter (space between the skewers).

FRONT

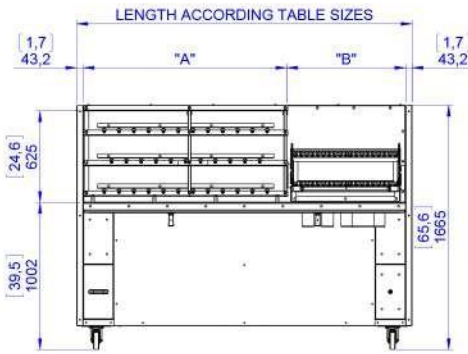

BACK*

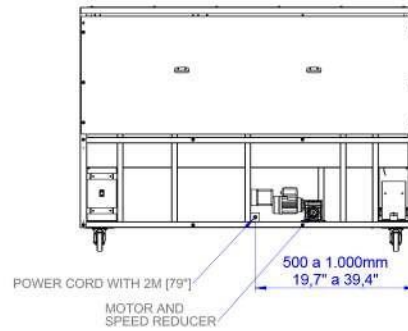

SIDE

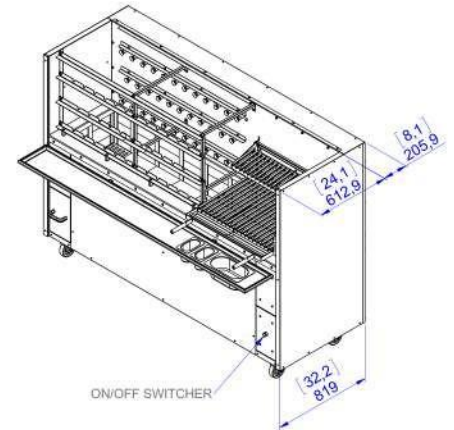

*Back clearance 100mm / 4 inches;
 **Fire pit cooking area depth 460mm / 18 inches x Length from table below.

TABEL SIZES

"A" - ROTISSERIE**

Overall Length	Galleries	Skewers
1000 / 39 3/8	2	13
	3	20
1200 / 47 1/4	2	17
	3	26
1500 / 59 1/16	2	23
	3	35
1800 / 70 7/8	2	29
	3	44
2000 / 78 3/4	2	33
	3	50

"B" - LIFT GRILL

Overall Length	COOKING AREA LENGTH / DENPTH
500 / 19 11/16	365 / 14,37 / 489 / 19,25
600 / 23 5/8	465 / 18,30 / 489 / 19,25
700 / 27 9/16	565 / 22,24 / 489 / 19,25
1000 / 39 3/8	865 / 34,05 / 489 / 19,25
1200 / 46 1/4	1065 / 41,92 / 489 / 19,25
1500 / 59 1/16	1365 / 53,74 / 489 / 19,25

**Dimensions in milimetres / inches.

HOOD

Ventilation calculations need to be confirmed by a local specialist mechanical ventilation consultant or contractor to make sure the system meets local codes.

For USA only:

MAX COOKING SURFACE TEMP °F	MINIMUM EXHAUST AIRFLOW (CFM/FT)*
400	275
600	275
700	300+

*Exhaust airflow is capable of being as low as listed above. Since charcoal will be giving off grease laden smoke, it is important to capture all the smoke by providing a larger amount of CFM for the capture of the smoke produced by these solid fuel appliances.

MAX COOKING SURFACE TEMP °F	LENGHT (FT)**	WIDTH (IN)***
400	3 min / 16 max	39 min / 72 max
600	3 min / 16 max	39 min / 72 max
700	5 min / 16 max	39 min / 72 max

Note:
 1. There needs to be a 6" overhang on either side of the appliance being used for correct sizing of the hood system. Ex: char broiler is 36". Hood length needs to be 42".
 2. Charcoal (solid fuel) appliances need to be hooded separate from any other appliances. Cannot mix gas and solid fuel appliances under same hood.

Exception, if the hood is up against a sidewall, disregard 6" overhang where hood is on sidewall.

UTILITY INFORMATION

ELECTRICITY

- This machine requires motor 110V or 240 V, 5.85 Amp, 50HZ or 60HZ single phase power; please specify when ordering;
- Electricity plug finished with 79' (2,00m) cord. Depending of the unit size this cord can vary;
- Manual starter.

MISCELLANEOUS

- Check local codes for fire and sanitary regulations, manufacturer is not responsible for installation.

OPTIONAL ITEMS

- Front counter to help chef's operation (foldable or not) and it can come with opening for GN tray;
- Ash collector drawer;
- Charcoal storage compartment;
- Front bar 4.75mm (stronger);
- Manual or automatic up/down grilling system;
- Side Lifter Grill - It is an automatic up/down grill located on the side panel of the unit. This part increases in 60mm / 2 23/64 the overall length of this equipment. Two Grill Options:



500 / 19 11/16
 1000 / 39 3/8