

# MENDOZA 903

Firepit



## EQUIPMENT SHEET | MENDOZA 903 Firepit

### AVAILABLE SIZES

- Equipment available in 2 sizes: 1570mm/61.81" and 1970mm/77.55".

Equipment Measurement (Grill + Firebox + Grill)
585+400+585mm/23,03+15,74+23,03" (total length 1570mm/61,81")
785+400+785mm/30,90+15,74+30,90" (total length 1970mm/77,55")

### BENEFITS

- Stainless steel structure, ensuring robustness, corrosion resistance and excellent durability to the equipment;
- Steering wheel with antireverse technology (grille remains at the desired height without the need for locking);
- Fire box for bench with refractory bricks and thermal insulation.

### EQUIPMENT INSTALLATION

- Easy installation, just place the equipment inside the bench;
- Do not install the product exposed to the weather or sea air.

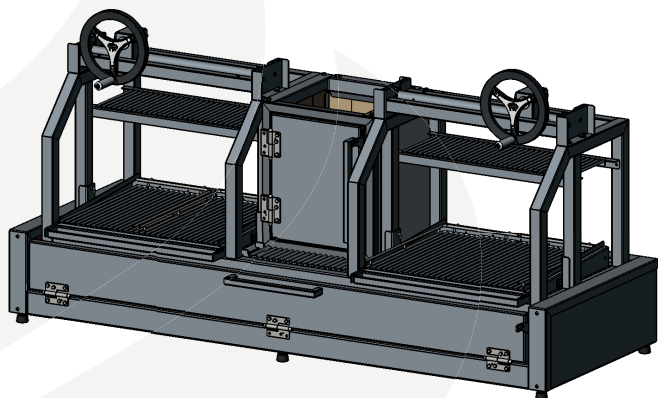

Example of the photo: Parrilla Mendoza 903 - 585+400+585mm/23,03+15,74+23,03"

## FIREPIT INSTALLATION

PROJECTED VIEW

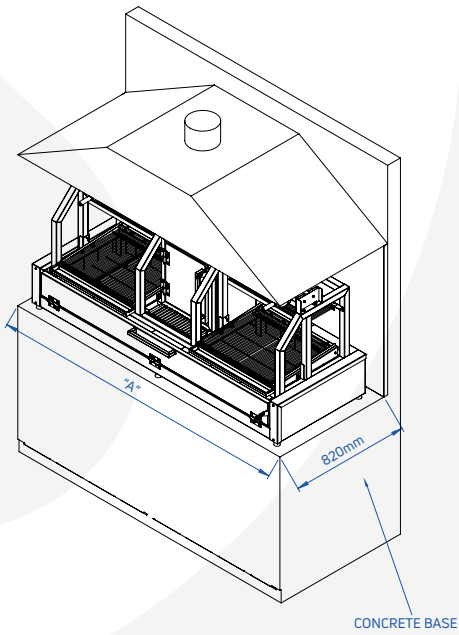

CUTTING SIDE VIEW

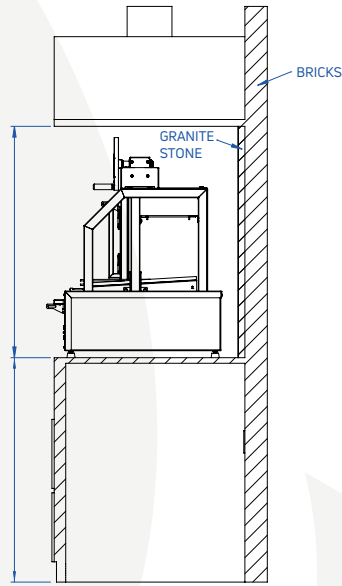

FRONT VIEW

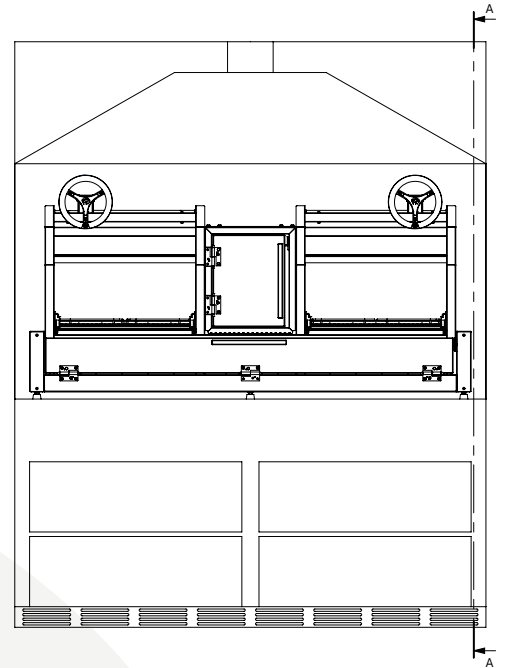

Section A

MEASUREMENT TABLE A

Equipment Measurement (Grill + Firebox + Grill)	Measure A
585+400+585mm/23,03+15,74+23,03" (total length 1570mm/61,81")	1750mm/68,89"
785+400+785mm/30,90+15,74+30,90" (total length 1970mm/77,55")	2150mm/84,64"

- All dimensions in millimeters (mm) and inches (").
- Other dimensions upon request.
- It is recommended to install a hood with a suction system to eliminate gases and smoke generated by burning coal and to remove heat generated inside the bench.
- The width of the hood must be greater than the width of the equipment.

## EQUIPMENT PACKAGING

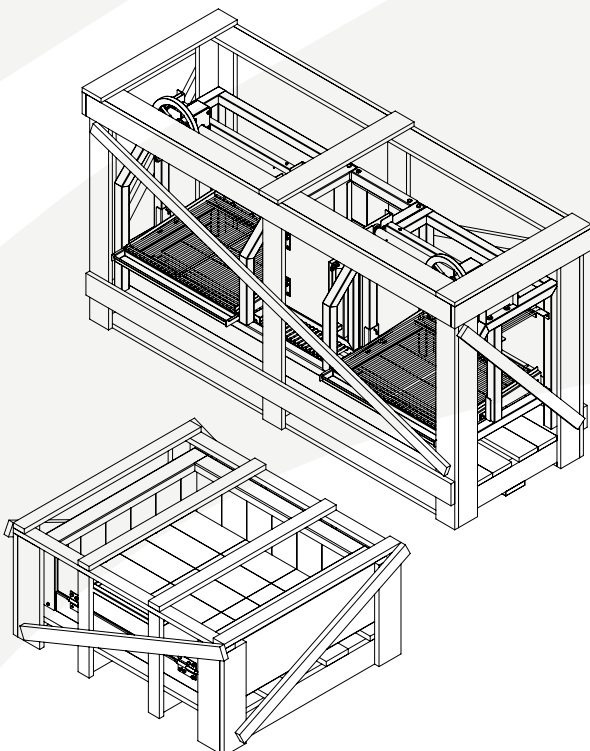

WEIGHTS AND MEASURES CONSIDERING STANDARD MEASUREMENT

Size of Mendoza 903	Weight (net)	Dimensions with packaging (in millimeters and inches)	Weight (gross)
1570mm/61,81"	337Kg/743lb	1800 x 750 x 1060mm/70,86 x 29,52 x 41,73"	385Kg/849lb
1970mm/77,55"	423Kg/932lb	2200 x 750 x 1060mm/86,61 x 29,52 x 41,73"	484Kg/1067lb

WEIGHTS AND MEASURES CONSIDERING STANDARD MEASUREMENT

Size of Firepit	Weight (net)	Dimensions with packaging (in millimeters and inches)	Weight (gross)
1705mm/67,12"	225Kg/496lb	1875 x 970 x 490mm/73,81 x 34,25 x 19,29"	268Kg/590lb
2105mm/82,87"	270Kg/595lb	2275 x 870 x 490mm/89,56 x 34,25 x 19,29"	319Kg/703lb



## OPTIONAL ACCESSORIES

To make your barbecue even better, Scheer offers you accessories of the highest quality and performance.



Charcoal Spreader

## IMPORTANT

- It is possible to use combustible materials, as long as they are inside the firebox;
- Burning wood must only be done inside the firebox, allowing the use of firewood, wood or sticks on the barbecue.

### SCHEER CHURRASQUEIRAS E PARRILLAS

Address: KM 148, BR-116, 17204 | CEP 95054-780  
Sagrada Família | Caxias do Sul | RS | Brasil

Website: [www.scheer.com.br](http://www.scheer.com.br)  
Contact: +55 54 3224.3066  
E-mail: [scheer@scheer.com.br](mailto:scheer@scheer.com.br)



### USA:

+1 9544152161 – ZAFILL.COM

### EUROPE:

+31 6 82902464 – ABMBBQ.NL

### JAPAN:

+81 3 3280 1035 – SCHEER.JP

### AUSTRALIA:

+61 2 9986 2004 – PROLINEEQUIPMENT.COM.AU

### SOUTH AFRICA:

+27 11 568 4598 – SCHEER.CO.ZA

