



CHARCOAL PARRILLA 652S



EXAMPLE PHOTO :
2200mm / 78 3/4
TWO LIFT GRILLS AND
400mm / 15 3/4
CENTRAL FIRE LIGHTER

FEATURES | BENEFITS

CUSTOMIZED CONSTRUCTION

- Equipment's length customized according to the customer needs from 800 / 31 1/2 up to 2500 / 98 7/16.

LIFT GRILL SYSTEM

- Grilling area is equipped with motorized up/down lifting grill system.

FIRE LIGHTER

- This is a particular area with door to feed the unit with charcoal, wood or a mixture can be used in fire pit so when charcoal is hot you just spread it along the fire pit. When using wood a fire wood basket is required.

HYGIENE

- Equipment coated in brushed stainless steel AISI 304 or AISI 430 (please specify when ordering).

"V" SHAPED GRILL

- "V" shaped mild steel grill with a grease collector tray.

HIGH QUALITY

- Equipment designed and built with high quality to provide the best results to the final user.

REST VEGETABLES GRILL

- Extra level of grill to be used as a rest for vegetables, garlic bread, etc.

SIMPLE TO USE

- Equipment easy and simple to use.

MACHINE STRUCTURE

- Internal tube structure carbon steel;
- 5" casters which helps the displacement for maintenance and cleaning;
- Carbon steel tank SAE 1020 cover with refractory bricks;
- High grade heat insulation under refractory bricks in fire pit saves 20-30% charcoal usage;
- Easy way to remove and maintain the refractory bricks with "T" bar system;
- Two years parts and labor warranty from date of purchase;

SCHEER CHURRASQUEIRAS
RUA ROQUE CALLEGE, 133 |
CEP 95041-440 | BAIRRO UNIVERSITÁRIO
CAXIAS DO SUL | RS | BRAZIL

BRAZIL:
+55 54 3224.3066
SCHEER.COM.BR

UNITED STATES:
+1 954 4152161
SCHEERUSA.COM

JAPAN:
+81 3 3280 1035
KYODAIMARKET.
COM

AUSTRALIA:
+61 2 9986 2004
PROLINEEQUIPMENT.
COM.AU



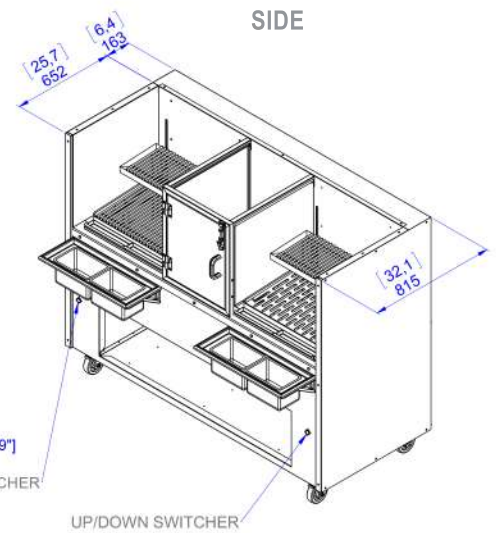
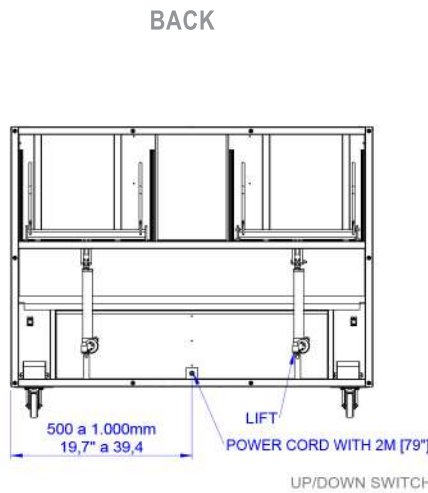
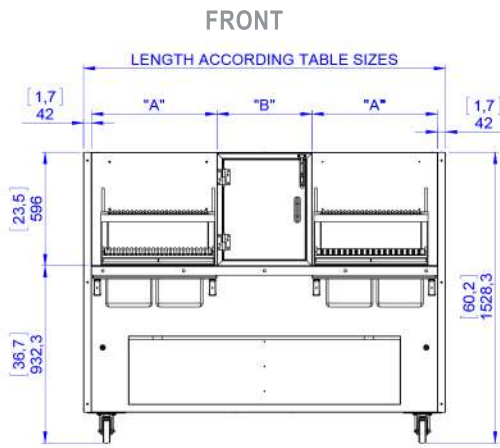

*Back clearance 100mm / 4 inches;

TABEL SIZES

"A" - PARRILLA** OVERALL LENGTH	"B" - FIRE LIGHTER OVERALL LENGTH	COOKING AREA LENGTH / DEPTH
800 / 31 3/8	400 / 15 3/4	665 / 26,18" / 545 / 21,45"
1000 / 39 3/8	500 / 19 11/16	865 / 34,05" / 545 / 21,45"
1200 / 47 1/4	600 / 23 5/8	1065 / 41,92" / 545 / 21,45"
1500 / 59 1/16	700 / 27 9/16	1365 / 53,74" / 545 / 21,45"
1800 / 70 7/8		1665 / 65,55" / 545 / 21,45"
2000 / 78 3/4		1865 / 73,42" / 545 / 21,45"
2200 / 86 5/8		2065 / 81,29" / 545 / 21,45"
2500 / 98 7/16		2365 / 93,11" / 545 / 21,45"

*Dimensions in milimetres / inches;

**For special size consult our staff;

***Grill section maximum length 1500mm / 59 1/16; when over this size unit will have two section or more.

HOOD

Ventilation calculations need to be confirmed by a local specialist mechanical ventilation consultant or contractor to make sure the system meets local codes.

For USA only:

MAX COOKING SURFACE TEMP °F	MINIMUM EXHAUST AIRFLOW (CFM/FT)*
400	275
600	275
700	300+

*Exhaust airflow is capable of being as low as listed above. Since charcoal will be giving off grease laden smoke, it is important to capture all the smoke by providing a larger amount of CFM for the capture of the smoke produced by these solid fuel appliances.

MAX COOKING SURFACE TEMP °F	LENGHT (FT)**	WIDTH (IN)***
400	3 min / 16 max	39 min / 72 max
600	3 min / 16 max	39 min / 72 max
700	5 min / 16 max	39 min / 72 max

Note:
 1. There needs to be a 6" overhang on either side of the appliance being used for correct sizing of the hood system. Ex: char broiler is 36". Hood length needs to be 42".
 2. Charcoal (solid fuel) appliances need to be hooded separate from any other appliances. Cannot mix gas and solid fuel appliances under same hood.

Exception, if the hood is up against a sidewall, disregard 6" overhang where hood is on sidewall.

UTILITY INFORMATION

ELECTRICITY

- This machine requires motor 110V or 240 V, 5.85 Amp, 50HZ or 60HZ single phase power; please specify when ordering;
- Electricity plug finished with 79' (2,00m) cord. Depending of the unit size this cord can vary;

MISCELLANEOUS

- Check local codes for fire and sanitary regulations, manufacturer is not responsible for installation.

OPTIONAL ITEMS

- Front counter to help chef's operation (foldable or not) and it can come with opening for GN tray;
- Ash collector drawer;
- Charcoal storage compartment;
- Round stainless steel grid;
- Fire wood basket;
- Flat stainless steel grid for fish;
- Black carbon steel finishing plate version instead of stainless steel.