



## PROFESSIONAL BBQ GRILL IG 500



EXAMPLE PHOTO IG 500 WITH  
50 SKEWERS AND 3 GALLERIES

SCHEER CHURRASQUEIRAS  
RUA ROQUE CALLEGE, 133 |  
CEP 95041-440 | UNIVERSITÁRIO |  
CAXIAS DO SUL | RS | BRAZIL

BRAZIL:  
+55 54 3224.3066  
SCHEER.COM.BR

UNITED STATES:  
+1 954 4152161  
SCHEERUSA.COM

JAPAN:  
+81 3 3280 1035  
KYODAIMARKET.COM

AUSTRALIA:  
+61 2 9986 2004  
PROLINEEQUIPMENT.COM.AU



## FEATURES | BENEFITS

### CUSTOMIZED CONSTRUCTION

Equipment's length customized according to the customer needs from 39 3/8" (1,00m) up to 98 7/16" (2,50m).

### HYGIENE

Equipment coated in brushed stainless steel AISI 304 or AISI 430 and including casters to help the cleaning proposes.

### FREE SMOKE FORMATION

It has a stainless steel water tank to collect grease and also to eliminate the smoke formation besides making easier the cleaning job. It has a stainless steel water tank to collect grease and also to eliminate the smoke formation besides making easier the cleaning job.

### FAST ROASTING USING INFRARED BURNERS

Heating source is infrared burners Scheer Gas grills are built with 8 up to 22 infrared burners corresponding to the size of the grill as table attached.

### INLET AND OUTLET WATER

Equipment has inlet water tap to fill it up during the beginning of operation and out let water tap to draining it out during the end of operation.

### DOUBLE SPECIAL SCHEER BUSHING

Special Scheer bushing that does not require oil lubrication.

### STAINLESS STEEL SKEWERS

Skewers made with stainless steel blade, zamaq roller and coated aluminum handle.

### HIGH QUALITY

Equipments designed and built with high quality to provide the best results to the final user.

### SIMPLE TO USE

Equipment easy and simple to use after installation.

### DRIVE MECHANISM

Individual gear drives each skewer, skewers next to each other rotate in opposite directions to avoid clipping of meats.

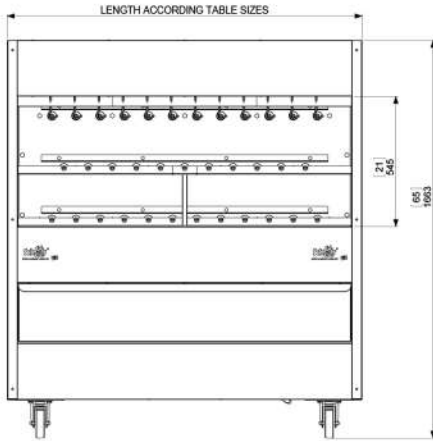
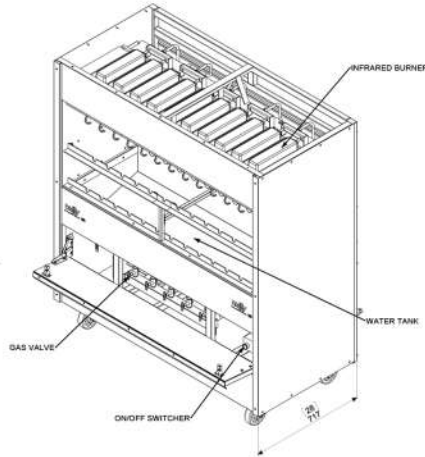
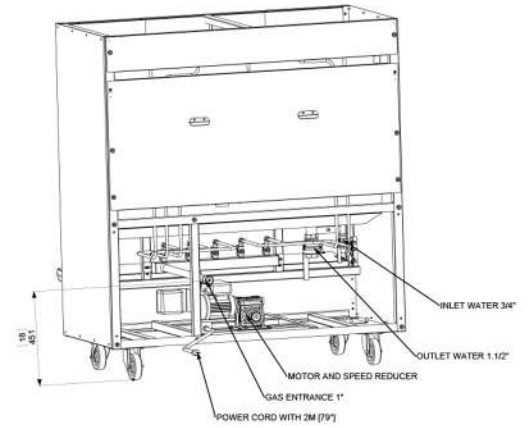
**FRONT**

**SIDE**

**BACK**

**TABLE SIZES (MILIMITERS / INCHES)**

Galleries	Skewers	Burners	BTUS	Width	Depth	Height
2	13	8	72000	1000 (39 3/8")	717 (28")	1663 (65")
2	17	10	90000	1200 (47 1/4")	717 (28")	1663 (65")
2	23	12	108000	1500 (59 1/16")	717 (28")	1663 (65")
2	29	16	144000	1800 (70 7/8")	717 (28")	1663 (65")
2	33	18	162000	2000 (78 3/4")	717 (28")	1663 (65")
2	37	20	180000	2200 (86 5/8")	717 (28")	1663 (65")
2	43	22	198000	2500 (98 7/16")	717 (28")	1663 (65")

Galleries	Skewers	Burners	BTUS	Width	Depth	Height
3	20	8	72000	1000 (39 3/8")	717 (28")	1663 (65")
3	26	10	90000	1200 (47 1/4")	717 (28")	1663 (65")
3	32	12	108000	1400 (54 1/4")	717 (28")	1663 (65")
3	35	12	108000	1500 (59 1/16")	717 (28")	1663 (65")
3	44	16	144000	1800 (70 7/8")	717 (28")	1663 (65")
3	50	18	162000	2000 (78 3/4")	717 (28")	1663 (65")
3	56	20	180000	2200 (86 5/8")	717 (28")	1663 (65")
3	65	22	198000	2500 (98 7/16")	717 (28")	1663 (65")

**HOOD**

Ventilation calculations need to be confirmed by a local specialist mechanical ventilation consultant or contractor to make sure the system meets local codes.

For USA only:

MAX COOKING SURFACE TEMP °F	MINIMUM EXHAUST AIRFLOW (CFM/FT)*
400	135
600	150
700	150

\*Exhaust airflow is capable of being as low as listed above. Since there is no grease laden smoke entering the airstream because it is being captured by means of the water tank in the appliance, these airflows can remain at 150 cfm/ft to exhaust the heat alone.

MAX COOKING SURFACE TEMP °F	LENGHT (FT)**	WIDTH (IN)***
400	3 min / 16 max	39 min / 72 max
600	3 min / 16 max	39 min / 72 max
700	5 min / 16 max	39 min / 72 max

Note: There needs to be a 6" overhang on either side of the appliance being used for correct sizing of the hood system. Ex: char broiler is 36". Hood length needs to be 42".

**UTILITY INFORMATION**
**GAS**

- Each infrared burner uses 9.000 BTU'S.
- All sectional units require a regulated gas supply. If using a flexible gas hose connection the inside diameter of the hose must not be smaller than main gas entrance (1") and must comply with local codes providing an adequate means of restraint to prevent undue strain on the gas connection;
- Natural gas or propane gas available;
- Manifold Pressure: 7 in W.C. for natural gas and 11 in W.C. for propane;
- For use in combustibile and noncombustibile location.
- A gas pressure regulator is required and it does not come with the unit.

**ELECTRICITY**

- Machine requires motor 110V or 220 V / 5.85 A / 50HZ or 60 HZ single phase power (specify when ordering);
- Electricity plug finished with 6' cord with 3 prong plug;
- Manual On / Off switch;
- Motor 1/4 hp.

**MISCELLANEOUS**

- Installation under a vented hood only.
- Check local codes for fire and sanitary regulations.
- The installer must plumb the line with backflow prevention. The hydraulic installation for inlet and outlet water must comply with local codes. The installation should be done by a qualified plumber.
- The manufacturer is not responsible for product installation.
- Approval by NSF.