

Custom Fireplace Program Co-linear Powervented Fireplaces

ENLIGHT COLLECTION - BAY Installation and Operating Manual NG & Propane

DO NOT DISCARD

Installer: Leave this manual with the appliance.
Consumer: Retain this manual for future reference.

WARNING: If the information in these instructions are not followed exactly, a fire or explosion may result causing property damage, personal injury or loss of life.

- Do not store or use gasoline or other flammable vapors and liquids in the vicinity of this or any other appliance.
- **WHAT TO DO IF YOU SMELL GAS**
 - Do not try to light any appliance.
 - Do not touch any electrical switch; do not use any phone in your building.
 - Immediately call your gas supplier from a neighbor's phone. Follow the gas supplier's instructions.
 - If you cannot reach your gas supplier, call the fire department.
- Installation and service must be performed by a qualified installer, service agency or the gas supplier.

WARNING



**HOT GLASS WILL
CAUSE BURNS.
DO NOT TOUCH GLASS
UNTIL COOLED.
NEVER ALLOW CHILDREN
TO TOUCH GLASS.**



We recommend that our gas hearth products be installed and serviced by professionals who are certified in the U.S. by the National Fireplace Institute (NFI) as NFI Gas Specialists.

1 - SAFETY INFORMATION

This fireplace complies with ANSI Z21.50-2019/CSA 2.22-2019 Vented Gas Fireplaces and CAN/CSA P.4.1-15.
Installation must conform with local building codes or in the absence of local building codes,
with the National Fuel Gas Code, ANSIZ223.1/NFPA 54 - Current Edition, or the Natural or Propane Installation Code, CSAB149.1

A. SAFETY ICON DESIGNATIONS

Various safety icons appear throughout this installation manual. Please familiarize yourself with the icons making sure you understand the serious consequences that may occur if ignored or of handling the products inappropriately.



IMPORTANT NOTE

This indicates additional instructions that you should consider during the installation.



DO NOT

This indicates something that you must never do.



RISK OF FIRE

This designates a danger of risk of fire or damage to property.



HOT GLASS WARNING

This indicates danger of serious bodily injury or property damage if glass is handled while still hot.



CAUTION

This indicates danger of serious bodily injury or property damage



STOP!

This indicates notes that may include reviewing warnings on other pages throughout the manual

B. IMPORTANT SAFETY CONSIDERATIONS

- Installation and repair should be done only by a qualified service person. The appliance should be inspected by a qualified service person before use. Annual inspection by a qualified service person is required to maintain warranty. More frequent cleaning may be required due to excessive lint from carpeting, bedding materials, etc. It is imperative that control compartments, burners and circulation air passageways of the appliance be kept clean.
 - Children and adults should be alerted to the hazards of high surface temperatures and should stay away to avoid burns or clothing ignition.
 - Young children should be carefully supervised when they are in the same room as the appliance. Toddlers, young children and others may be susceptible to accidental contact burns. A physical barrier is recommended if there are at risk individuals in the house. To restrict access to a fireplace or stove, install an adjustable safety gate to keep toddlers, young children and other at risk individuals out of the room and away from hot surfaces.
 - Clothing or other flammable material should not be placed on or near the appliance.
 - Adequate accessibility clearances for servicing and proper operation must be maintained.
 - This appliance must not share or be connected to a chimney flue serving any other appliance.
 - Keep area around the appliance clear of combustible materials, gasoline and other flammable vapor and liquids.
 - The flow of combustion and ventilation air must not be obstructed.
 - Due to high temperatures the appliance should be located out of traffic and away from furniture and draperies.
 - The glass front or any part removed for servicing the appliance must be replaced prior to operating the appliance. Work should be done by a qualified service technician.
 - Clean glass only when cool and only with non-abrasive cleansers.
 - Do not operate this appliance with the glass/frame assembly removed, cracked or broken. Replacement of the glass assembly must only be performed by a licensed or qualified service person. **DO NOT SUBSTITUTE MATERIALS.**
 - Do not strike or slam glass assembly.
 - Keep burner and control compartment clean.
 - Do not use this fireplace if any part has been under water. Immediately call a qualified service technician to inspect this appliance and to replace any part of the control system and any gas control which has been under water.
 - **DANGER: Under no circumstances should any solid fuel (wood, coal, paper or cardboard etc.) be used in this appliance.**
 - **STATE OF CA WARNING:** This product and the fuels used to operate this product (liquid propane or natural gas), and the combustion of such fuels, can expose you to chemicals including benzene, which is known to the State of California to cause cancer and reproductive harm.
- For more information go to: www.P65Warnings.ca.gov.

2 - COMMONWEALTH OF MASSACHUSETTS REQUIREMENTS



NOTE: THE FOLLOWING REQUIREMENTS REFERENCE VARIOUS MASSACHUSETTS AND NATIONAL CODES NOT CONTAINED IN THIS MANUAL.

For all sidewall horizontally vented gas fueled equipment installed in every dwelling, building or structure used in whole or in part for residential purposes, including those owned or operated by the Commonwealth and where the side wall exhaust vent termination is less than (7) feet above finished grade in the area of the venting, including but not limited to decks and porches, the following requirements shall be satisfied:

INSTALLATION OF CARBON MONOXIDE DETECTORS

At time of installation of side wall horizontally vented gas fueled equipment, the installing plumber or gas-fitter shall observe that a hard wired carbon monoxide detector with an alarm and battery back-up is installed on the floor level where the gas equipment is to be installed. In addition, the installing plumber or gas-fitter shall observe that a battery operated or hard wired carbon monoxide detector is installed on each additional level of the dwelling, building or structure served by the side wall horizontal vented gas fueled equipment. It shall be the responsibility of the property owner to secure the services of qualified licensed professionals for the installation of hard wired carbon monoxide detectors.

In the event that the side wall horizontally vented gas fueled equipment is installed in a crawl space or attic, the hard wired carbon monoxide detector with alarm and battery back-up may be installed on the next adjacent floor level.

In the event that the requirements of this subdivision can not be met at the time of completion of installation, the owner shall have a period of thirty (30) days to comply with the above requirements; provided, however, that during said thirty (30) day period, a battery operated carbon monoxide detector with an alarm shall be installed.

APPROVED CARBON MONOXIDE DETECTORS

Each carbon monoxide detector as required in accordance with the above provisions shall comply with NFPA 720 and be ANSI/UL 2034 listed and IAS certified.

SIGNAGE

A metal or plastic identification plate shall be permanently mounted to the exterior of the building at a minimum of eight (8) feet above grade directly in line with the exhaust vent terminal for the horizontally vented gas fueled heating appliance or equipment. The sign shall read, in print no less the one-half inch (1/2) in size, "GAS VENT DIRECTLY BELOW. KEEP CLEAR OF ALL OBSTRUCTIONS".

INSPECTION

The state or local gas inspector of the side wall horizontally vented gas fueled equipment shall not approve the installation unless, upon inspection, the inspector observes carbon monoxide detectors and signage installed in accordance with the provisions of 248 CMR 5.08 (2) (a) 1 through 4.

EXEMPTIONS

The following equipment is exempt from 248 CMR 5.08 (2) (a) 1 through 4: The equipment listed in Chapter 10 entitled "Equipment Not Required To Be Vented" in the most current edition of NFPA 54 as adopted by the Board; and Product Approved side wall horizontally vented gas fueled equipment installed in a room or structure separate from the dwelling, building or structure used in whole or in part for residential purposes.

MANUFACTURES REQUIREMENTS GAS EQUIPMENT VENTING SYSTEM PROVIDED

When the manufacturer of Product Approved side wall horizontally vented gas equipment provides a venting system design or venting system components with the equipment, the instructions provided by the manufacturer for installation of the equipment and the venting system shall include:

Detailed instructions for the installation of the venting system design or the venting system components; and a complete parts list for the venting system design or venting system.

MANUFACTURES REQUIREMENTS GAS EQUIPMENT VENTING SYSTEM NOT PROVIDED

When the manufacturer of Product Approved side wall horizontally vented gas equipment does not provide the parts for venting the flue gases, but identifies "special venting systems", the following requirements shall be satisfied by the manufacturer:

The referenced "special venting systems" instructions shall be included with the appliance or equipment installation instructions and; the "special venting systems" shall be Product Approved by the Board, and the instructions for that system shall include a parts list and detailed Installation instructions.

A copy of all installation instructions for all Product Approved side wall horizontally vented gas fueled equipment, all venting instructions, all parts lists for venting instructions, and/or all venting design instructions shall remain with the appliance or equipment at the completion of the installation.

3 - SPECIFICATIONS

			DIMENSIONS: INCHES [MILLIMETERS]							
MODEL	B-VENT FLUE	AIR INTAKE COLLAR	Finishing Width - Front	Finishing Height	Finishing Width - Ends	Height To Top Trim	Overall Height	Center Of Vent	Depth	Overall Width
	Diameter	Diameter	A	B	C	D	E	F	G	H
3BY-20GL	8"	10"	N/A	20 [508]	22-3/16 [564]	38 [1,067]	46 [1,168]	20-7/8 [530]	24-1/32 [610]	41-3/4 [1,065]
4BY-20GL	8"	10"	N/A	20 [508]	22-3/16 [564]	38 [1,067]	46 [1,168]	26-7/8 [683]	24-1/32 [610]	53-3/4 [1,365]
5BY-20GL	8"	10"	N/A	20 [508]	22-3/16 [564]	38 [1,067]	46 [1,168]	32-7/8 [835]	24-1/32 [610]	65-3/4 [1,670]
6BY-20GL	10"	10"	N/A	20 [508]	22-3/16 [564]	38 [1,067]	46 [1,168]	38-7/8 [987]	24-1/32 [610]	77-3/4 [1,975]
7BY-20-GL	10"	10"	N/A	20 [508]	22-3/16 [564]	38 [1,067]	46 [1,168]	44-7/8 [1,140]	24-1/32 [610]	89-3/4 [2,280]
8BY-20GL	10"	12"	N/A	20 [508]	22-3/16 [564]	40 [1,016]	52 [1,321]	50-7/8 [1,292]	24-1/32 [610]	101-3/4 [2,584]
3BY-24GL	8"	10"	N/A	24 [610]	22-3/16 [564]	42 [1,067]	50 [1,270]	20-7/8 [530]	24-1/32 [610]	41-3/4 [1,065]
4BY-24GL	8"	10"	N/A	24 [610]	22-3/16 [564]	42 [1,067]	50 [1,270]	26-7/8 [683]	24-1/32 [610]	53-3/4 [1,365]
5BY-24GL	8"	10"	N/A	24 [610]	22-3/16 [564]	42 [1,067]	50 [1,270]	32-7/8 [835]	24-1/32 [610]	65-3/4 [1,670]
6BY-24GL	10"	10"	N/A	24 [610]	22-3/16 [564]	42 [1,067]	50 [1,270]	38-7/8 [987]	24-1/32 [610]	77-3/4 [1,975]
7BY-24GL	10"	10"	N/A	24 [610]	22-3/16 [564]	42 [1,067]	50 [1,270]	44-7/8 [1,140]	24-1/32 [610]	89-3/4 [2,280]
3BY-24GL	10"	12"	N/A	24 [610]	22-3/16 [564]	44 [1,118]	56 [1,422]	50-7/8 [1,292]	24-1/32 [610]	101-3/4 [2,584]
3BY-30GL	8"	10"	N/A	30 [762]	22-3/16 [564]	48 [1,219]	56 [1,422]	20-7/8 [530]	24-1/32 [610]	41-3/4 [1,065]
4BY-30GL	8"	10"	N/A	30 [762]	22-3/16 [564]	48 [1,219]	56 [1,422]	26-7/8 [683]	24-1/32 [610]	53-3/4 [1,365]
5BY-30GL	8"	10"	N/A	30 [762]	22-3/16 [564]	48 [1,219]	56 [1,422]	32-7/8 [835]	24-1/32 [610]	65-3/4 [1,670]
6BY-30GL	10"	10"	N/A	30 [762]	22-3/16 [564]	48 [1,219]	56 [1,422]	38-7/8 [987]	24-1/32 [610]	77-3/4 [1,975]
7BY-30GL	10"	10"	N/A	30 [762]	22-3/16 [564]	48 [1,219]	56 [1,422]	44-7/8 [1,140]	24-1/32 [610]	89-3/4 [2,280]
8BY-30GL	10"	12"	N/A	30 [762]	22-3/16 [564]	50 [1,270]	62 [1,574]	50-7/8 [1,292]	24-1/32 [610]	101-3/4 [2,584]
3BY-36GL	8"	10"	N/A	36 [914]	22-3/16 [564]	54 [1,372]	62 [1,575]	20-7/8 [530]	24-1/32 [610]	41-3/4 [1,065]
4BY-36GL	8"	10"	N/A	36 [914]	22-3/16 [564]	54 [1,372]	62 [1,575]	26-7/8 [683]	24-1/32 [610]	53-3/4 [1,365]
5BY-36GL	8"	10"	N/A	36 [914]	22-3/16 [564]	54 [1,372]	62 [1,575]	32-7/8 [835]	24-1/32 [610]	65-3/4 [1,670]
6BY-36GL	10"	10"	N/A	36 [914]	22-3/16 [564]	54 [1,372]	62 [1,575]	38-7/8 [987]	24-1/32 [610]	77-3/4 [1,975]
7BY-36GL	10"	10"	N/A	36 [914]	22-3/16 [564]	54 [1,372]	62 [1,575]	44-7/8 [1,140]	24-1/32 [610]	89-3/4 [2,280]
8BY-36GL	10"	12"	N/A	36 [914]	22-3/16 [564]	56 [1,422]	68 [1,727]	50-7/8 [1,292]	24-1/32 [610]	101-3/4 [2,584]
3BY-48GL	8"	10"	N/A	48 [1,219]	22-3/16 [564]	66 [1,676]	74 [1,880]	20-7/8 [530]	24-1/32 [610]	41-3/4 [1,065]
4BY-48GL	8"	10"	N/A	48 [1,219]	22-3/16 [564]	66 [1,676]	74 [1,880]	26-7/8 [683]	24-1/32 [610]	53-3/4 [1,365]
5BY-48GL	8"	10"	N/A	48 [1,219]	22-3/16 [564]	66 [1,676]	74 [1,880]	32-7/8 [835]	24-1/32 [610]	65-3/4 [1,670]
6BY-48GL	10"	10"	N/A	48 [1,219]	22-3/16 [564]	66 [1,676]	74 [1,880]	38-7/8 [987]	24-1/32 [610]	77-3/4 [1,975]
7BY-48GL	10"	10"	N/A	48 [1,219]	22-3/16 [564]	66 [1,676]	74 [1,880]	44-7/8 [1,140]	24-1/32 [610]	89-3/4 [2,280]
8BY-48GL	10"	12"	N/A	48 [1,219]	22-3/16 [564]	68 [1,727]	80 [2,032]	50-7/8 [1,292]	24-1/32 [610]	101-3/4 [2,584]
3BY-60GL	8"	10"	N/A	60 [1,521]	22-3/16 [564]	78 [1,981]	86 [2,184]	20-7/8 [530]	24-1/32 [610]	41-3/4 [1,065]
4BY-60GL	8"	10"	N/A	60 [1,521]	22-3/16 [564]	78 [1,981]	86 [2,184]	26-7/8 [683]	24-1/32 [610]	53-3/4 [1,365]
5BY-60GL	8"	10"	N/A	60 [1,521]	22-3/16 [564]	78 [1,981]	86 [2,184]	32-7/8 [835]	24-1/32 [610]	65-3/4 [1,670]
6BY-60GL	10"	10"	N/A	60 [1,521]	22-3/16 [564]	78 [1,981]	86 [2,184]	38-7/8 [987]	24-1/32 [610]	77-3/4 [1,975]
7BY-60GL	10"	10"	N/A	60 [1,521]	22-3/16 [564]	78 [1,981]	86 [2,184]	44-7/8 [1,140]	24-1/32 [610]	89-3/4 [2,280]
8BY-60GL	10"	12"	N/A	60 [1,521]	22-3/16 [564]	80 [2,032]	92 [2,337]	50-7/8 [1,292]	24-1/32 [610]	101-3/4 [2,584]

The dimensions in green are the allowable finishing width and height required to fit the glass into the fireplace. Finishing materials must not overlap onto glass.

3 - SPECIFICATIONS

A. DIMENSIONS

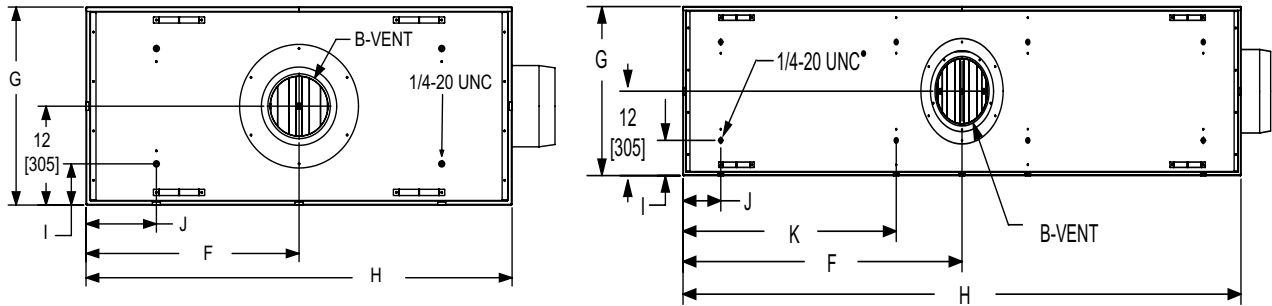

TOP VIEW

I, J & K	The hood shall be supported at specific locations using 1/4-20 UNC threaded rods. You will find the dimensions for I, J & K in Section 3 (Prepare The Fireplace).
----------	---

FRONT VIEW

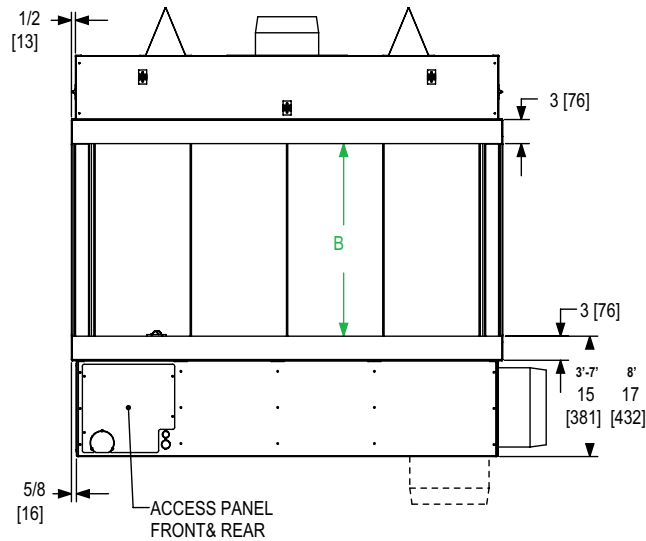

LEFT SIDE VIEW

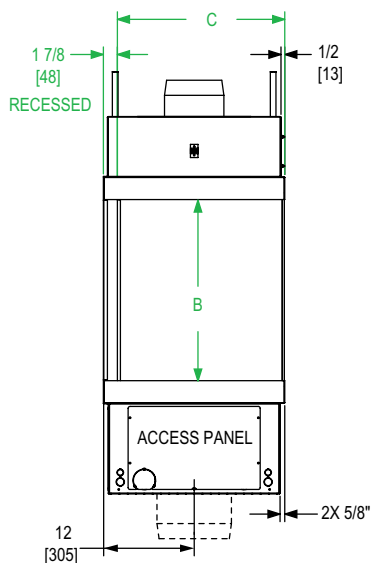

RIGHT SIDE VIEW

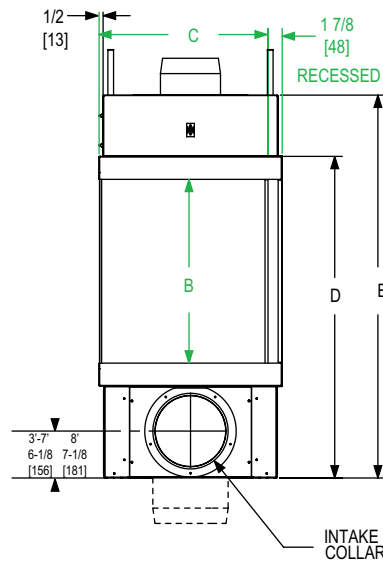

Figure 3A

3 - SPECIFICATIONS

B.1 GAS & ELECTRIC ACCESS LOCATIONS (3', 4', 5', 6' & 7')

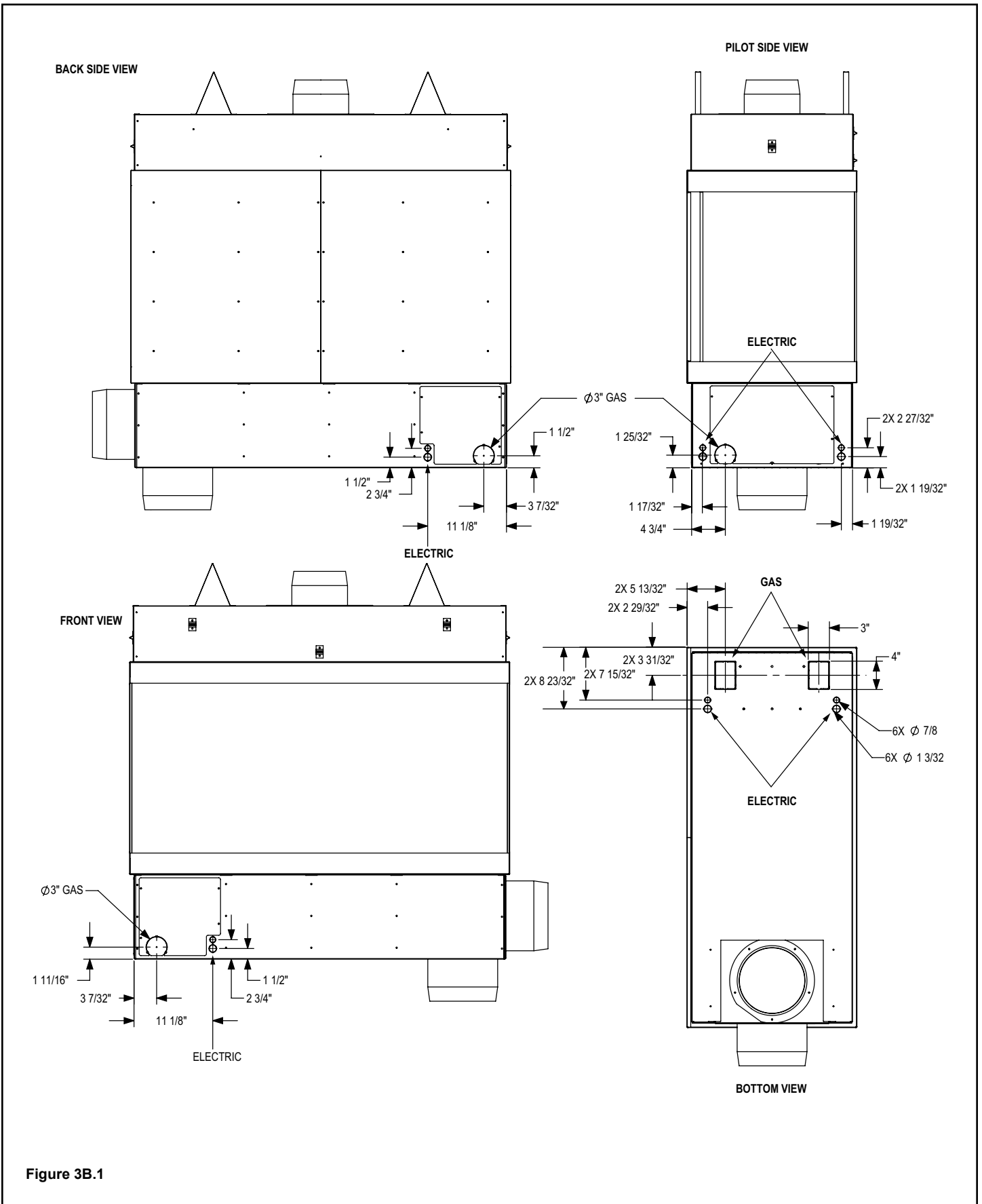

Figure 3B.1

3 - SPECIFICATIONS

B. 2 GAS & ELECTRIC ACCESS LOCATIONS (8')

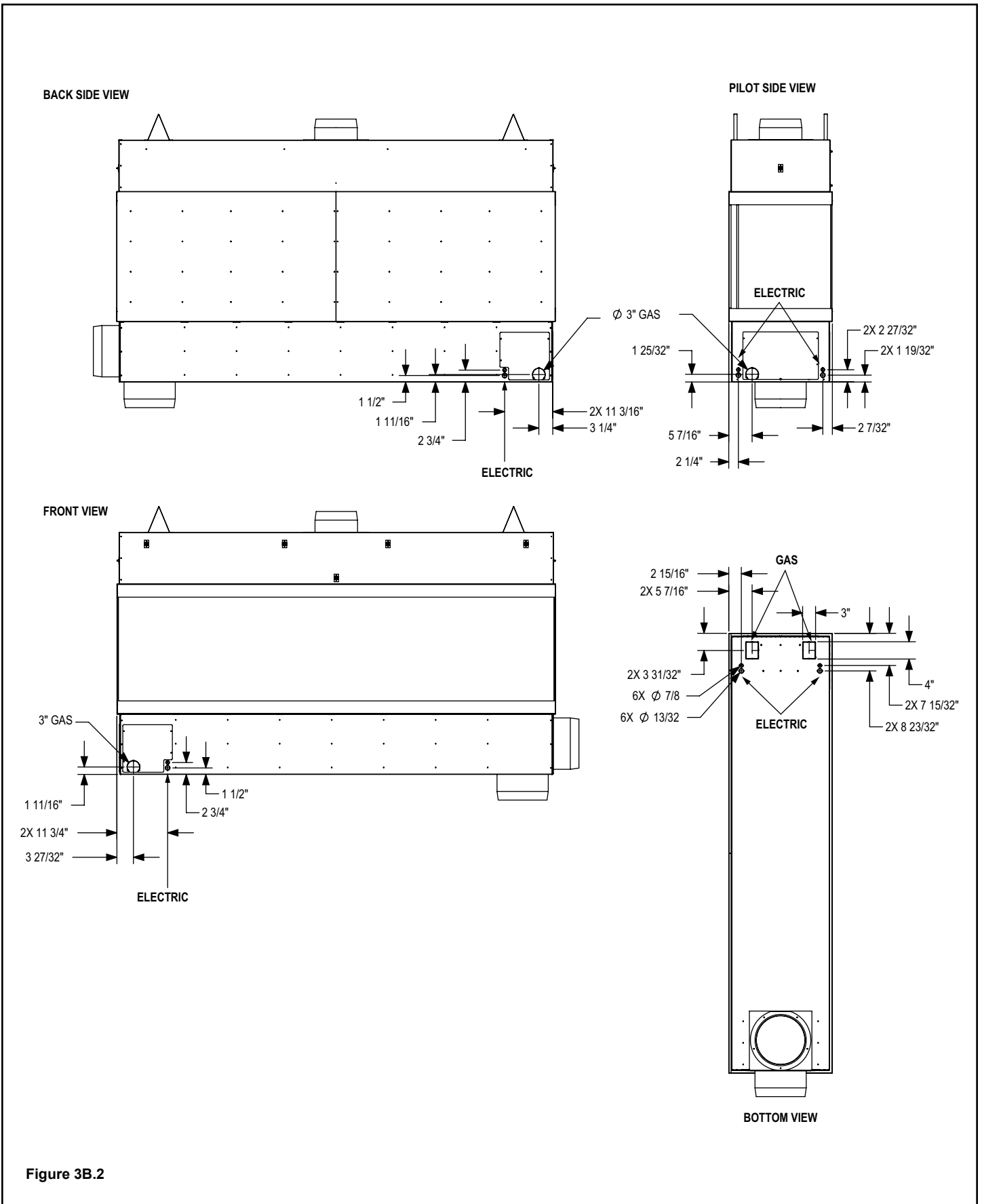

Figure 3B.2

3 - SPECIFICATIONS

C. SPECIFICATIONS

Model #	DESCRIPTION	B-VENT	OA	REG PV	IN-LINE PV	BTU'S	NG ORIFICE	Propane ORIFICE
3'	ANY HEIGHT	8"	10"	RS12	RSIF160	40,000	(2X) #43	(2X) #55
4'	ANY HEIGHT	8"	10"	RS12	RSIF160	60,000	(3X) #43	(3X) #55
5'	ANY HEIGHT	8"	10"	RS12	RSIF160	80,000	(4X) #43	(4X) #55
6'	ANY HEIGHT	10"	10"	RS14	RSIF180	100,000	(5X) #43	(5X) #55
7'	ANY HEIGHT	10"	10"	RS14	RSIF180	120,000	(6X) #43	(6X) #55
8'	ANY HEIGHT	10"	12"	RS14	RSIF180	140,000	(7X) #43	(7X) #55



WARNING: NON-COMBUSTIBLE ZONE: USE ONLY NON-COMBUSTIBLE MATERIAL IN THIS AREA FOR ENTIRE WIDTH OF FIREPLACE. DO NOT USE WOOD, SHEETROCK, ETC., IN THIS ZONE.



NOTE: OTHER CLEARANCES APPLY. ALL CLEARANCES MUST BE MAINTAINED.
Refer to Section 4 (Framing), Section 5 (Non-combustible Zone) and Section 10 (Finishing) for more information.



NOTE: The qualified installer should follow the procedure best suited for the installation.

D. INSTALLATION OVERVIEW

1. Frame should be built after the fireplace is installed or extra clearance must be planned for at the intake collar. Framing must allow for vent installation.
2. If masonry (optional) will be used, prepare foundation for the masonry load. A lintel is required to support the added weight above the fireplace.
3. Install hearth if desired.
4. Insert fireplace into framing.
5. Double check clearances to combustibles.
6. Complete gas line installation.
7. Complete electrical hook-up.
8. Complete venting installation.
9. Install facing material, mantel or cabinetry.
10. Install glass media/natural stone, and any interior options including mirrors and/or driftwood log set.
11. Verify proper operation of fireplace and all components.

E. PLACEMENT CLEARANCE REQUIREMENTS

- This fireplace must be installed on a level surface capable of supporting the fireplace and venting.
- Fireplace must be placed directly on wood or non-combustible surface (not linoleum or carpet) extending entire depth and width of fireplace.
- This fireplace may be installed in a bedroom.

3 - SPECIFICATIONS

F. CLEARANCES

From unit left & right sides	1"	25mm
To flooring under fireplace	0	0
Unit top to ceiling	6"	152mm
Unit side to adjacent sidewall	1"	25mm

Figure 3F

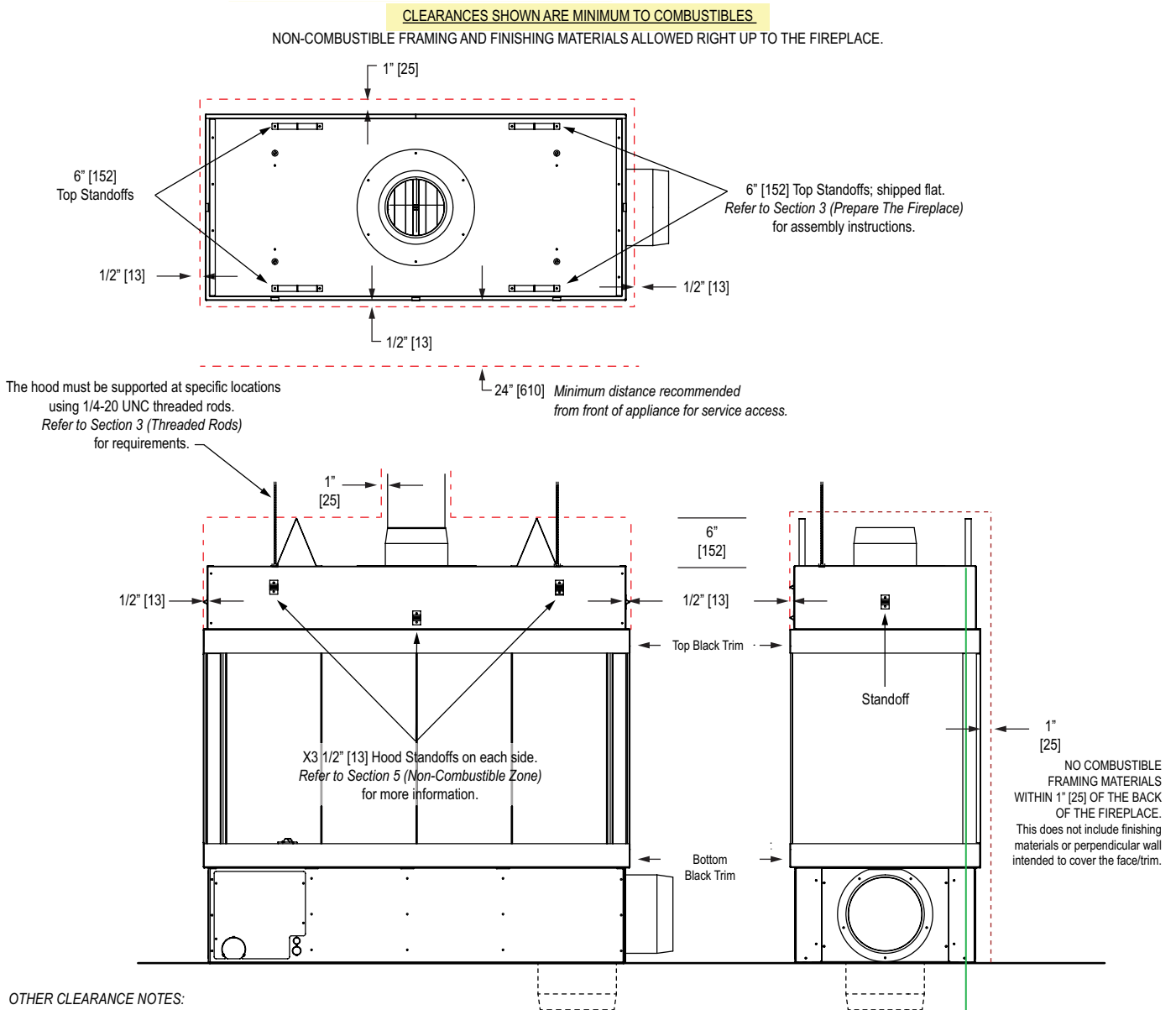

OTHER CLEARANCE NOTES:

- No combustible material within 6" [152] of the top of the fireplace.
- No combustible material within 1 [25] around the B-Vent flue.
- Combustible finishing materials may cover the 3" [76] top and bottom black trim. Do not overlap glass.
- Combustible framing allowed right up to the fireplace below the viewing area only.
- A combustible mantel may be placed at the top of the viewing area. Do not overlap glass.
- A combustible hearth extension may be used below the viewing area. Do not overlap glass.
- Do not place on carpet, vinyl or soft surfaces.

Can be a recess and/or combustible perpendicular wall extending past the face of the fireplace. Refer to Section 2 (Left Corner Dimensions) for more measurements.

4 - PREPARE THE FIREPLACE



CAUTION: FIREPLACE IS NOT LOAD-BEARING.



NOTE: OTHER CLEARANCES APPLY. ALL CLEARANCES MUST BE MAINTAINED.

A. STANDOFF INSTALLATION

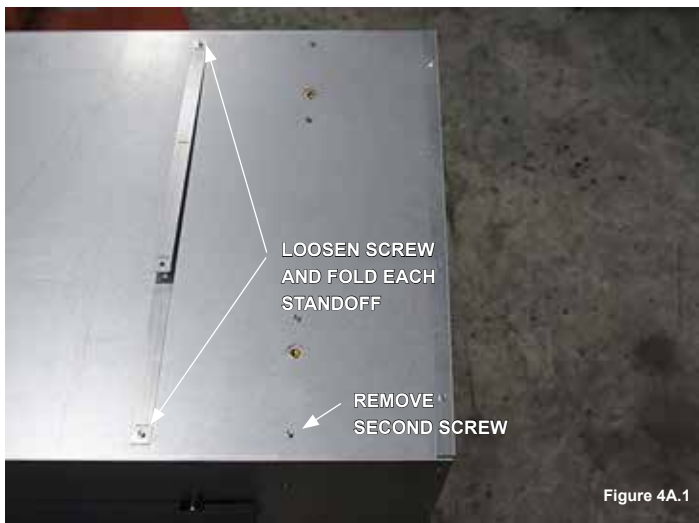

Figure 4A.1



Figure 4A.2

STEP 1: Refer to Figure 4A.1

The (4) standoffs will be shipped in a flat state placed on the firebox top. Locate the standoffs and loosen the screws holding them in place.

STEP 2: Refer to Figure 4A.2

Fold the center of the standoff up and both ends out at the perforated lines. Using Figure 4A.2 for reference, locate the second pre-installed screw on the firebox top at each standoff location. Remove the screw, pivot the folded standoff into location and re-install the screw to secure the standoff. Tighten up the screw that was loosened in Step 1.

STANDOFFS

The fireplace has top standoffs that are secured with two (2) screws each (left and right sides of top).

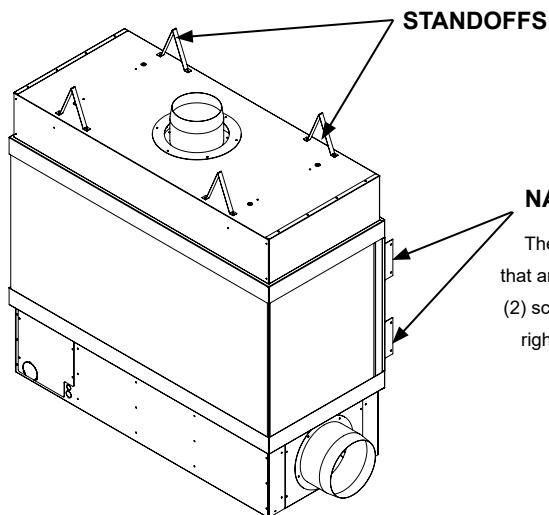
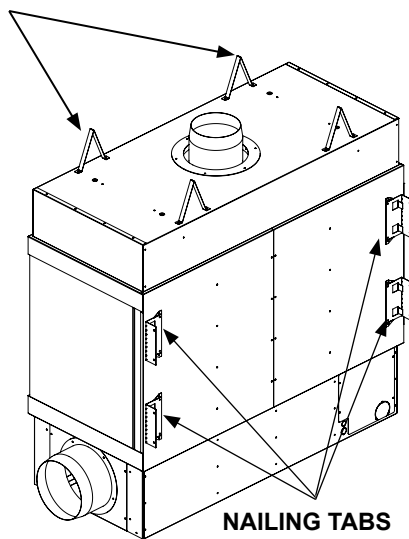

NAILING TABS

The fireplace has tabs that are secured with two (2) screws each (left and right sides of fireplace).

Figure 4A.3

Placement of the standoffs and nailing tabs.

4 - PREPARE THE FIREPLACE

B. NAILING TABS



Figure 4B.1

STEP 1: Refer to Figure 4B.1

The four (4) nailing tabs will be shipped in a flat state placed on the firebox back. Locate the nailing tabs and remove the screws holding them in place.



Figure 4B.2

STEP 2: Refer to Figure 4B.2

Bend the two (2) small tabs out on each nailing flange at the perforated lines. Using Figure 4A.4 for reference, locate the pre-drilled holes on the firebox side each nailing tab will be placed at.



Figure 4B.3

STEP 3: Refer to Figure 4B.3 & Figure 4B.4

Set each nailing tab in place and secure using two (2) screws each. Bend the nailing tab out from fireplace at the remaining perforated line.



Figure 4B.4



Figure 4B.5

The nailing tabs will ensure the 1" minimum clearance is kept to combustible framing. Refer to Figure 4B.5

Depending on your installation and how you frame it out, you may not use the provided nailing tabs.

4 - PREPARE THE FIREPLACE

C. SHIPPING SUPPORT BRACKETS

The hood must be supported at specific locations using 1/4-20 UNC threaded rods.

Temporary support brackets are put in place for shipping and installation support and must stay in place until fireplace hood is fully supported.

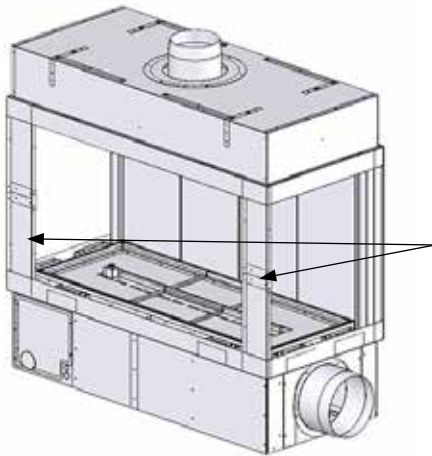

1. Install the threaded rods in the appropriate locations for I, J & K as noted below in Framing - A.
2. Level the fireplace.
3. Ensure fireplace is fully supported and leveled and then remove support brackets.

CAUTION! RISK OF INJURY!

DO NOT remove support brackets until fireplace is fully supported and level.

Figure 4C

Temporary Shipping Support Bracket

D. THREADED RODS

The bay fireplace requires 2 threaded rods to be placed at the glass-to-glass intersections.

Placement of the required threaded rods is at the I & J intersection at the front left and back BAYs notated as REQUIRED I & J locations.

Additional locations are provided if your installation needs more support notated as OPTIONAL I, J & K locations.

Once the required threaded rods are in place and the the hood fully supported, the temporary support brackets may be taken off.

See Page 11 for threaded rod installation option.

Figure 4D.1 - 3' 4' & 5' Models
Top View

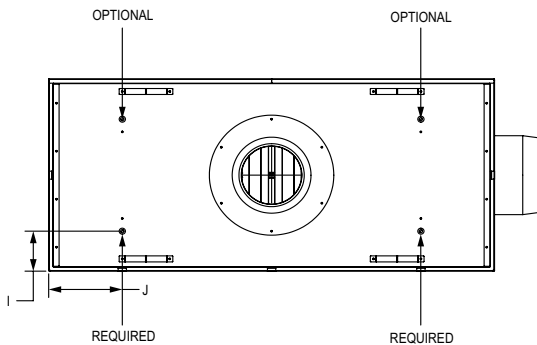
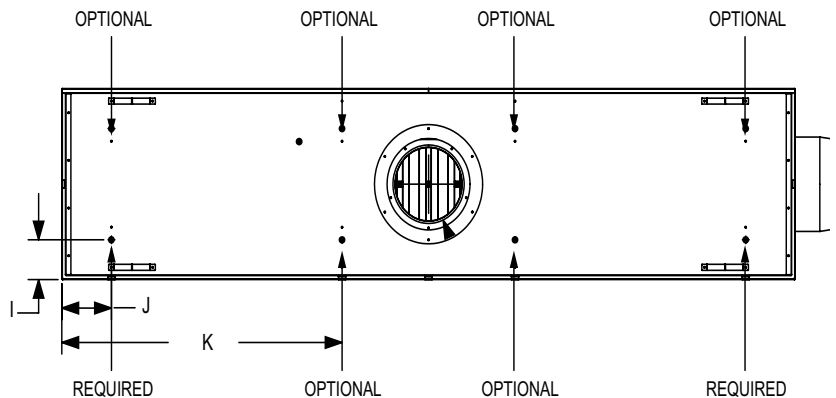

Figure 4D.2 - 6', 7' & 8' Models
Top View



The hood shall be supported at specific locations using 1/4-20 UNC threaded rods.								
Qty 2 threaded rods are required in the front and back left hand corner glass-to-glass intersections (I & J)								
All other locations are optional if additional support is needed.								
MODEL	QTY	Additional	I		J		K	
	REQ	OPT	INCHES	MM	INCHES	MM	INCHES	MM
3' BY	2	2	5	127	6-3/8	162	NA	NA
4' BY	2	2	5	127	8-7/8	225	NA	NA
5' BY	2	2	5	127	11-7/8	302	NA	NA
6' BY	2	6	5	127	6-7/8	175	26-7/8	683
7' BY	2	6	5	127	6-7/8	175	32-7/8	835
8' BY	2	6	5	127	6-7/8	175	38-7/8	987

4 - PREPARE THE FIREPLACE

E. THREADED RODS INSTALLATION (EXAMPLE)

There are several different ways to support the fireplace top and one option is to use a Unistrut installed over the fireplace that is secured to structurally sound framing. Refer to Figure 4B.

For each threaded rod installation you may need:



Super Strut
or Uni-Strut



Qty 1
1/4-20
Eyebolt



Qty
1 Threaded
Quick Link



Qty 1
1/4-20
Turnbuckle



Qty 1
1/4-20
Threaded Rod
or All Thread



Qty 1
Fender
Washer



Up To Qty 3
1/4-20
Nut

(Qty Per Threaded Rod Used)



Figure 4B

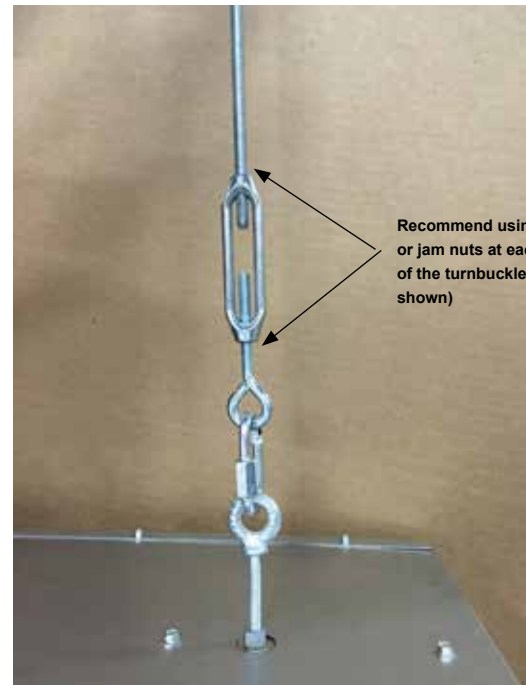

- Install the threaded rod fully into the threaded fastener located on top of the fireplace.
- Insert the threaded rod into a hole in the Unistrut straight above the threaded fastener located on top of the fireplace.
- Use a fender washer and nut on the top end of the threaded rod to adjust the height of the fireplace opening. Make sure the opening dimension is exact all the way around. Use Loctite to secure the nut from from loosening (not shown).
- If the top of the threaded rod is to be secured into blind threaded fastener or if there isn't clearance above to adjust the rod, you can use a turnbuckle to adjust the height.
- Install an eyebolt fully into the threaded nut located on top of the fireplace.
- Use a quick link to connect the eye bolt to the reverse thread side of the turnbuckle.
- Thread the threaded rod into the normal side of the turnbuckle.
- Use the locktight or jam nuts to secure the turnbuckle from loosening.

5 - FRAMING & MANTEL REQUIREMENTS



NOTE: Framing dimensions should allow for wall covering thickness and fireplace facing materials. When using a hearth, adjust rough opening size as necessary to maintain at least minimum clearance requirements.



CAUTION: Install fireplace on metal, concrete or hard wood surface extending the full width and depth of fireplace.



CAUTION: Vent cap location must be in compliance with guidelines in *Section 8 (Venting)* of this manual.

If masonry is to be used (optional), prepare the necessary foundation for the masonry load. When masonry construction is being used, a lintel must be used over top of fireplace to support the added weight. Build hearth to desired size and height. If a hearth extension is desired, combustible material may be used.



NOTE: REFER TO DIMENSIONS SECTION FOR ALLOWABLE FINISHING DIMENSIONS REQUIRED TO FIT THE GLASS PANELS INTO THE FIREPLACE. FINISHING MATERIALS MUST NOT OVERLAP THE DIMENSIONS HIGHLIGHTED IN GREEN IN *SECTION 2 (DIMENSIONS)*. NEVER COVER THE GLASS WITH FINISHING MATERIALS.



NOTE: DO NOT PIERCE ANY OF THE BLACK PAINTED SURFACES WITH SCREWS, RIVETS, ETC. THIS INCLUDES THE 3" [76] BLACK TOP AND BOTTOM GLASS TRIM AND ANY PAINTED SIDES ADJACENT TO THE GLASS.

IMPORTANT FRAMING NOTES:

THE FIREPLACE IS NOT LOAD-BEARING

FRAMING SHOULD BE BUILT AFTER THE FIREPLACE IS INSTALLED OR EXTRA CLEARANCE MUST BE PLANNED FOR AT THE INTAKE COLLAR AND FOR THE THICKNESS OF MATERIALS USED.

FRAMING DIMENSIONS ASSUMING 1/2" [13] DRYWALL AND NON-COMBUSTIBLE BOARD USED.

THESE DIMENSIONS REPRESENT THE FRAMING DIMENSIONS FOR COMBUSTIBLE MATERIAL.

NON-COMBUSTIBLE FRAMING AND FINISHING MATERIALS MAY BE USED WITHIN THESE DIMENSIONS RIGHT UP TO THE UNIT.

NO COMBUSTIBLE MATERIAL WITHIN 6" [152] OF THE TOP OF THE FIREPLACE.

NO COMBUSTIBLE MATERIAL WITHIN 1" [25] OF THE SIDES, BACK AND FRONT OF THE FIREPLACE.

COMBUSTIBLE MATERIAL SHALL NOT BE PLACED DIRECTLY ON THE FACE OF THE FIREPLACE, TOP AND SIDES.

SEE SECTION 5 (NON-COMBUSTIBLE ZONE) AND SECTION 10 (FINISHING) FOR DETAILS REGARDING 1/2" [25] STANDOFFS.

STEEL SURFACE MAY BE COVERED WITH NON-COMBUSTIBLE FINISHING MATERIAL.

1" CLEARANCE TO THE B-VENT MUST BE MAINTAINED.

5 - FRAMING & MANTEL REQUIREMENTS

Model	Framing Width	Framing Height	Framing Depth
	A	B	C
3BY-20GL	40-3/4 [1,035]	52 [1,321]	25-1/32 [636]
4BY-20GL	52-3/4 [1,340]	52 [1,321]	25-1/32 [636]
5BY-20GL	64-3/4 [1,645]	52 [1,321]	25-1/32 [636]
6BY-20GL	76-3/4 [1,949]	52 [1,321]	25-1/32 [636]
7BY-20GL	88-3/4 [2,254]	52 [1,321]	25-1/32 [636]
8BY-20GL	100-3/4 [2,559]	58 [1,473]	25-1/32 [636]
3BY-24GL	40-3/4 [1,035]	56 [1,422]	25-1/32 [636]
4BY-24GL	52-3/4 [1,340]	56 [1,422]	25-1/32 [636]
5BY-24GL	64-3/4 [1,645]	56 [1,422]	25-1/32 [636]
6BY-24GL	76-3/4 [1,949]	56 [1,422]	25-1/32 [636]
7BY-24GL	88-3/4 [2,254]	56 [1,422]	25-1/32 [636]
8BY-24GL	100-3/4 [2,559]	62 [1,574]	25-1/32 [636]
3BY-30GL	40-3/4 [1,035]	62 [1,574]	25-1/32 [636]
4BY-30GL	52-3/4 [1,340]	62 [1,574]	25-1/32 [636]
5BY-30GL	64-3/4 [1,645]	62 [1,574]	25-1/32 [636]
BY-30GL	76-3/4 [1,949]	62 [1,574]	25-1/32 [636]
7BY-30GL	88-3/4 [2,254]	62 [1,574]	25-1/32 [636]
8BY-30GL	100-3/4 [2,559]	68 [1,727]	25-1/32 [636]
3BY-36GL	40-3/4 1,035]	68 [1,727]	25-1/32 [636]
4BY-36GL	52-3/4 [1,340]	68 [1,727]	25-1/32 [636]
5BY-36GL	64-3/4 [1,645]	68 [1,727]	25-1/32 [636]
6BY-36GL	76-3/4 [1,949]	68 [1,727]	25-1/32 [636]
7BY-36GL	88-3/4 [2,254]	68 [1,727]	25-1/32 [636]
8BY-36GL	100-3/4 [2,559]	74 [1,880]	25-1/32 [636]
3BY-48GL	40-3/4 1,035]	80 [2,032]	25-1/32 [636]
4BY-48GL	52-3/4 [1,340]	80 [2,032]	25-1/32 [636]
5BY-48GL	64-3/4 [1,645]	80 [2,032]	25-1/32 [636]
6BY-48GL	76-3/4 [1,949]	80 [2,032]	25-1/32 [636]
7BY-48GL	88-3/4 [2,254]	80 [2,032]	25-1/32 [636]
8BY-48GL	100-3/4 [2,559]	86 [2,184]	25-1/32 [636]
3BY-60GL	40-3/4 1,035]	92 [2,337]	25-1/32 [636]
4BY-60GL	52-3/4 [1,340]	92 [2,337]	25-1/32 [636]
5BY-60GL	64-3/4 [1,645]	92 [2,337]	25-1/32 [636]
6BY-60GL	76-3/4 [1,949]	92 [2,337]	25-1/32 [636]
7BY-60GL	88-3/4 [2,254]	92 [2,337]	25-1/32 [636]
8BY-60GL	100-3/4 [2,559]	98 [2,489]	25-1/32 [636]

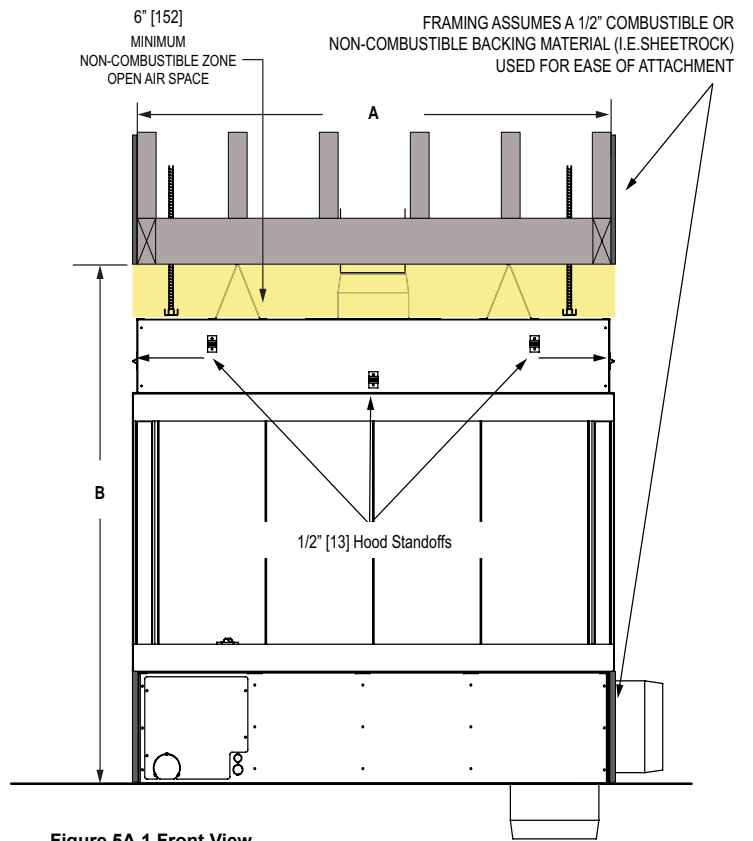

Figure 5A.1 Front View

Refer to Section 5 (Non-combustible Zone) for more information on the 1/2" [13] clearance standoffs.

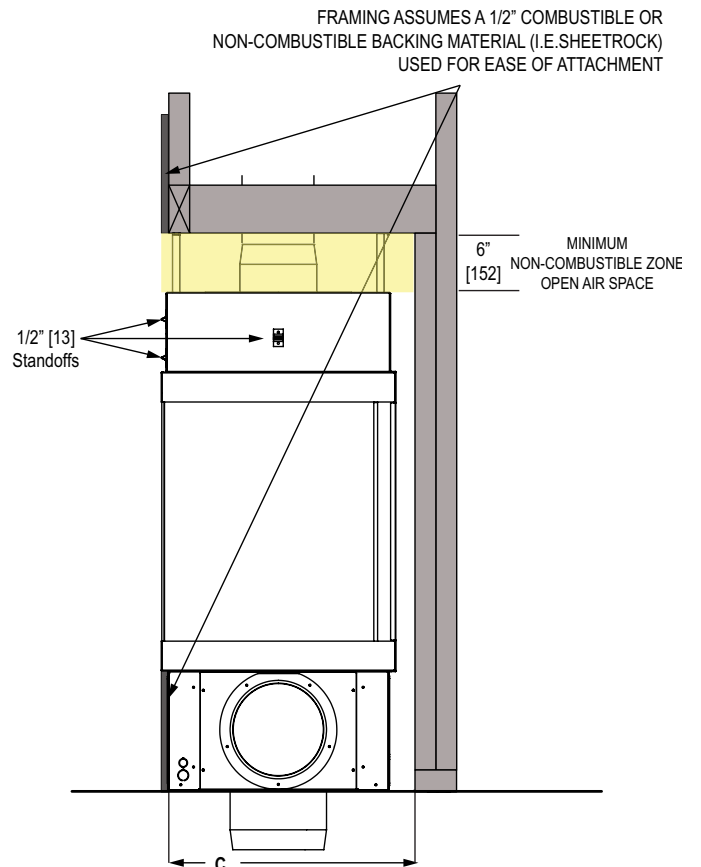

Figure 5A.1 Left Side View

5 - FRAMING & MANTEL REQUIREMENTS

B.1 NON-COMBUSTIBLE ZONE - USING THE PROVIDED 1/2" STANDOFFS

The fireplace has standoffs installed on the front of the fireplace standard from the factory. They are located on the upper left, center and right front of the fireplace and are to ensure that the 1/2" [12.7mm] required clearance to combustibles on the surface of the fireplace is maintained.

If the standoffs are removed, only non-combustible material can be installed against the surface of the fireplace such as a non-combustible backer cement board. 1/2" [12.7mm] minimum thickness must be used in the space* between the top of the 3" trim to the combustible framing the full width of the fireplace. The space* includes a 7" [178mm] minimum above the top of the fireplace that is recommended for ease of attachment. * = 15" [381] for 3'-7" units and 19" [483] for 8' units.



1/2" [12.7mm] Standoff

Refer to Figure 5B.1 below for a standard installation using the provided 1/2" standoffs.
Refer to Figure 5B.2 for requirements when not using the provided 1/2" standoffs.

WARNING! Risk of Fire
Comply with all the minimum clearances as specified.

Notes About TV Placement:
A mantel is not required if you are placing a TV above the opening.
No minimum clearance required for a TV above the fireplace opening.

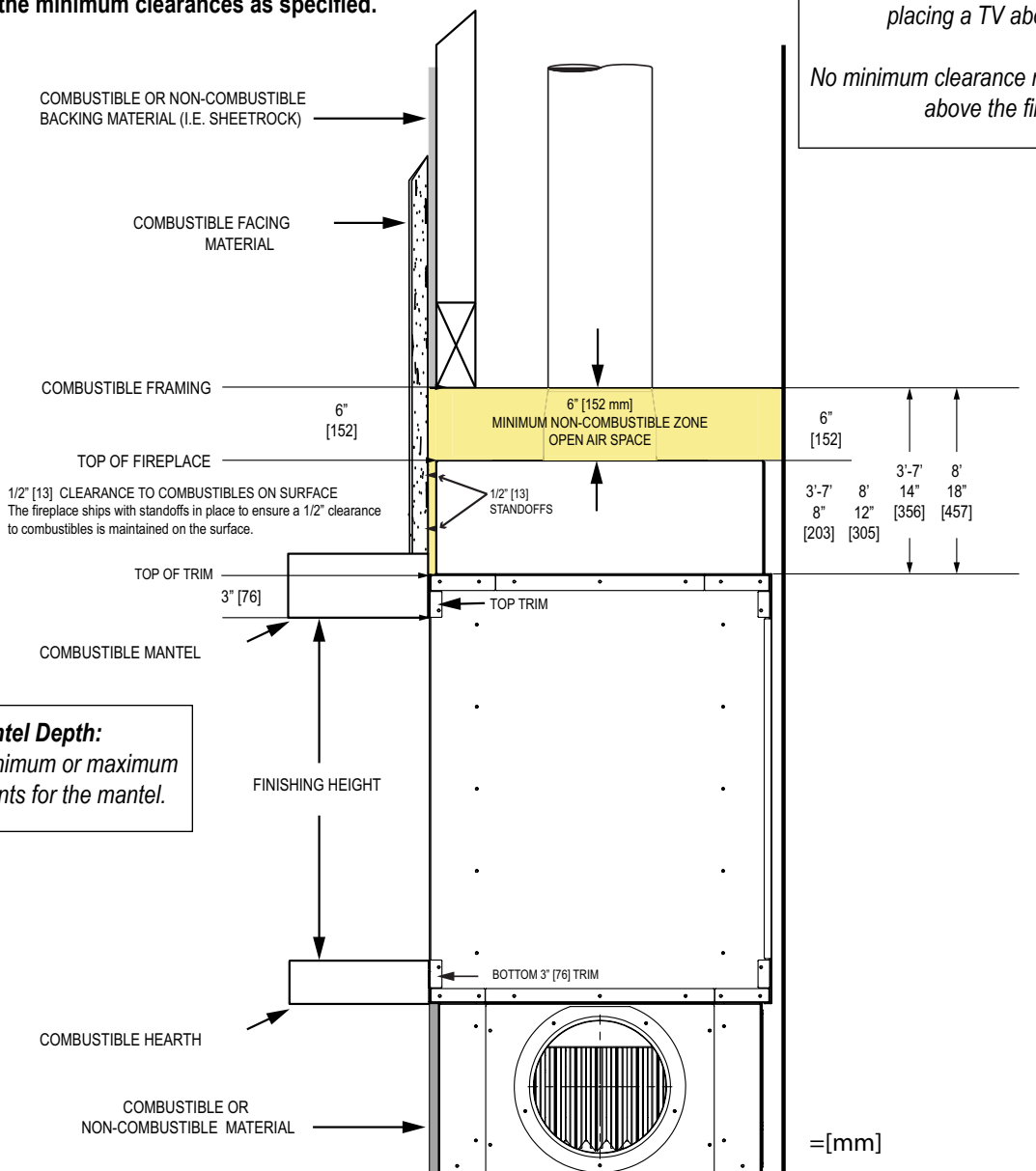

Note About Mantel Depth:
There are no minimum or maximum depth requirements for the mantel.

SINGLE SIDED EXAMPLE: RIGHT SIDE VIEW
APPLIES TO BOTH SIDES AND ENDS IF USING A MULTI-SIDED FIREPLACE

NOTE: Refer to Section 11 (Finishing The Wall) for more information.

Figure 5B.1

5 - FRAMING & MANTEL REQUIREMENTS

B.2 NON-COMBUSTIBLE ZONE - **NOT** USING THE PROVIDED 1/2" STANDOFFS

The fireplace has standoffs installed on the front of the fireplace standard from the factory. They are located on the left, center and right front hood of the fireplace and are to ensure that the 1/2" [12.7mm] required clearance to combustibles on the surface of the fireplace is maintained.

If the standoffs are removed, only non-combustible material can be installed against the surface of the fireplace such as a non-combustible backer cement board. 1/2" [12.7mm] minimum thickness must be used in the space* between the top of the 3" trim to the combustible framing the full width of the fireplace. The space* includes a 7" [178mm] minimum above the top of the fireplace that is recommended for ease of attachment. * = 15" [381] for 3'-7" units and 19" [483] for 8' units.



1/2" [12.7mm] Standoff

Refer to Figure 5B.2 below for requirements when not using the provided 1/2" standoffs.
Refer to Figure 5B.1 for a standard installation using the provided 1/2" standoffs.

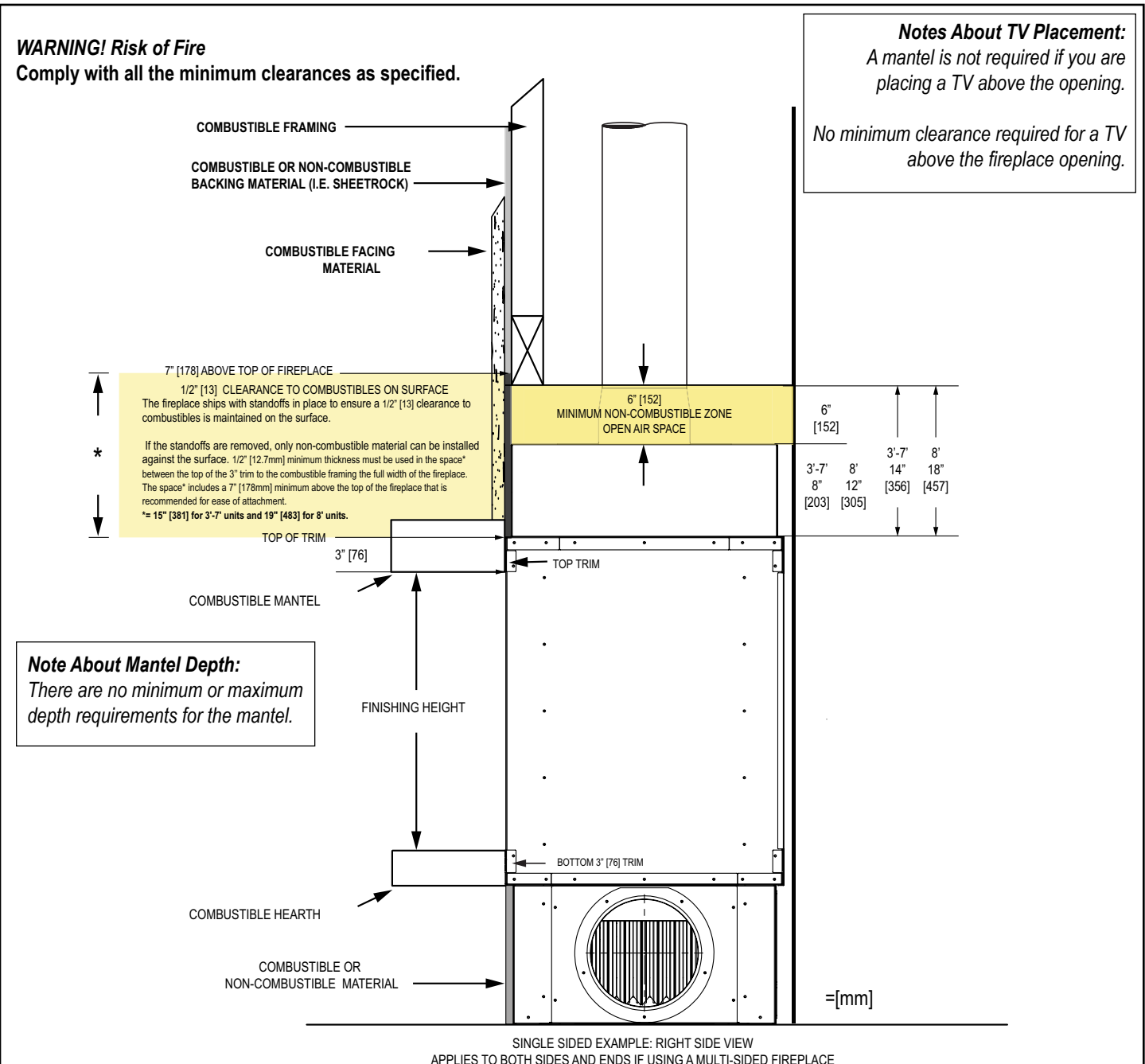

NOTE: Refer to Section 11 (Finishing The Wall) for more information.

Figure 5BB.2

6 - GLASS FRAME ASSEMBLY

A. GLASS FRAME ASSEMBLY IDENTIFICATION

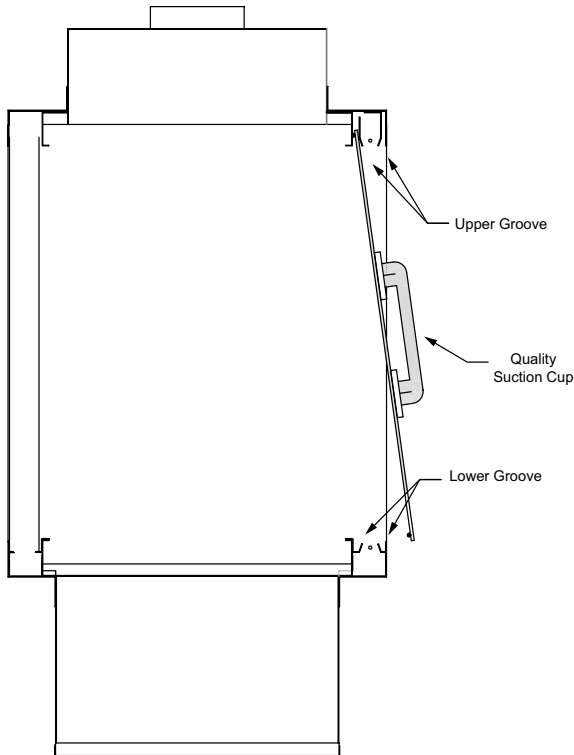

Figure 6A

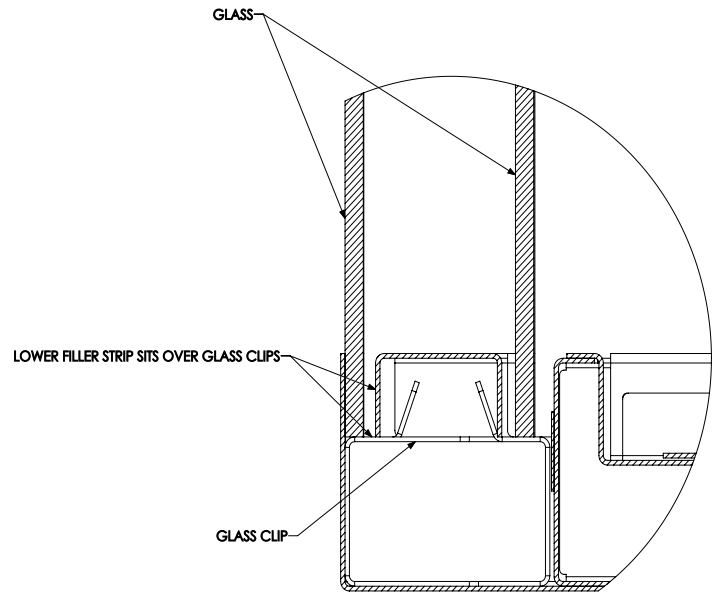

Figure 6B.1



CAUTION: TO PREVENT GLASS FRAME ASSEMBLY FROM FALLING FROM FIREPLACE AND BECOMING DAMAGED, FOLLOW THE INSTRUCTIONS EXACTLY WHEN REMOVING AND INSTALLING GLASS FRAME ASSEMBLY.



STOP: DO NOT OPERATE THIS FIREPLACE WITH THE GLASS REMOVED, CRACKED OR BROKEN. REPLACEMENT OF GLASS ASSEMBLY SHOULD BE DONE BY A LICENSED OR QUALIFIED SERVICE PERSON.



WARNING: DO NOT REMOVE GLASS ASSEMBLY WHEN HOT!!!!



NOTE: GLASS REMOVAL AND INSTALLATION MUST BE PERFORMED WITH TWO PEOPLE.



NOTE: Glass must be removed using quality suction cups. DO NOT attempt to remove the glass without using proper suction cups.



NOTE: IN CASE OF CHIPPED OR BROKEN GLASS
Due to the size and sensitivity of shipping the glass separately, it is best to have the replacement glass cut locally if needed. Have your local dealer assist you with contacting Stellar Hearth Products directly to get the proper glass specifications.

6 - GLASS FRAME ASSEMBLY

Refer to Section 6 (Glass Frame Assembly Identification Figures 6A & 6B.1) when installing and removing the glass frame assembly.

B. INSTALL GLASS FRAME ASSEMBLY



Figure 6B.2 - Outer Glass Edge Protector



Figure 6B.3 - Vertical Trim Piece



Figure 6B.4 - Horizontal Trim Piece

IMPORTANT: PLASTIC GLASS EDGE PROTECTORS

The fireplace is shipped with a plastic edge protector on the outer pane of glass only.

See Figure 6B.2

Inner Glass

1. Unwrap the panes of glass carefully making sure to protect the edges.
2. Apply the suction cups to the inner glass assembly, following instructions included with the suction cups.
3. Lift the glass into place. The top edge slips into the top groove; lift into the groove until the bottom is clear of the bottom trim. Slide the glass down into the inner bottom groove. See Figure 6A
4. Push vertical glass trim into place on each side. See Figure 6B.3
5. Place the long horizontal trim piece between the lower glass clips. Slide back against the vertical trim piece. See Figure 6B.3 and Figure 6B.4.

Outer Glass

6. Apply the suction cups to the outer unframed glass and lift it into place in the same manner as the inner glass.



WARNING: RISK OF INJURY!

DO NOT remove glass until unit is cooled to room temperature. Glass breakage could occur.

C. REMOVE GLASS FRAME ASSEMBLY

1. Apply the suction cups to the outer glass panel following the instructions included with the suction cups.
2. Gently lift the glass until the bottom edge is clear of the groove it sits in.
3. Bring the bottom edge of the glass towards you while lowering it to disengage it from the top groove.
4. Sit the glass on a padded surface to protect it. **IMPORTANT:** Protect the glass's edges.
5. Remove the lower trim piece that sits between the layer of glass.
6. Remove the inner trim vertical pieces.
7. Using the suction cups, remove the inner glass in the same manner.

7 - GAS LINE SPECIFICATIONS

This fireplace is manufactured for use with Natural Gas or Propane.

- CAUTION:** Installation of the gas line must only be done by a qualified person in accordance with local building codes, if any. If not, follow ANSI Z223.1.
- NOTE:** The appliance and its individual shutoff valve must be disconnected from the gas supply piping system during any pressure testing of that system at pressures in excess of ½ psi.
- NOTE:** The appliance must be isolated from the gas supply piping system by closing its individual manual shut-off valve during any pressure testing of the gas line at test pressures equal to or less than ½ psi (3.5 kPa).
- NOTE:** For high altitude installations, consult Stellar Hearth Products directly for proper rating methods.

GAS LINE CONNECTION	Propane	NG
MINIMUM INLET GAS PRESSURE	11.0 inches W.C. (recommended)	7.0 inches W.C. (recommended)
MAXIMUM INLET GAS PRESSURE	14.0 inches W.C.	10.0 inches W.C.
MANIFOLD PRESSURE (HI)	10.0 inches W.C.	3.5 inches W.C.
ORIFICE SIZE	See Specifications Chart in Section 3.C	See Specifications Chart in Section 3.C
INPUT BTU/HR	See Specifications Chart in Section 3.C	See Specifications Chart in Section 3.C

NOTE: Have the gas supply line installed in accordance with local codes. If not, follow ANSI Z223.1. Installation should be done by a qualified installer approved and/or licensed as required by the locality. In the Commonwealth of Massachusetts installation must be performed by a licensed plumber or gas fitter.

NOTE: A listed (and Commonwealth of Massachusetts approved) 1/2 in. [13] T-handle manual shut-off ball valve and flexible connector are connected to the 1/2" [13] control valve inlet.

Figure 7

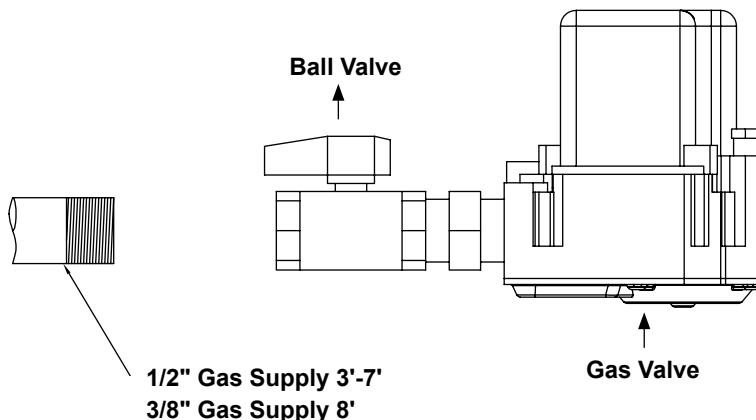

**ADDITIONAL INFORMATION
IN SECTION 2.B (GAS & ELECTRIC ACCESS LOCATIONS)**

8 - VENTING



CAUTION: Consult the local and national installation codes to assure adequate combustion and ventilation air is available.



NOTE: Flame height and appearance will vary depending upon venting configuration and type of fuel used. Venting requirements apply to both Natural and Propane gas.



STOP: MAINTAIN ALL CLEARANCES AS STATED IN THIS INSTALLATION MANUAL.

A. APPROVED VENTING

Model #	DESCRIPTION	B-VENT	OUTSIDE AIR	STANDARD POWERVENT	IN-LINE POWERVENTV
3'	ANY HEIGHT	8"	10"	RS12	RSIF160
4'	ANY HEIGHT	8"	10"	RS12	RSIF160
5'	ANY HEIGHT	8"	10"	RS12	RSIF160
6'	ANY HEIGHT	10"	10"	RS14	RSIF180
7'	ANY HEIGHT	10"	10"	RS14	RSIF180
8'	ANY HEIGHT	10"	12"	RS14	RSIF180

B. POWERVENT SUPPLY VOLTAGE

POWERVENT MODEL NUMBER	VAC	AMP	H/P
RS12 (3', 4', & 5' Models)	120	1.2	1/9
RS14 (6', 7' & 8' Models)	120	1.4	1/7
RSIF160 (3', 4', & 5' Models)	120	2.9	3/7
RSIF180 (6', 7' & 8' Models)	120	5.3	13/16

C. SYSTEM SUPPLY VOLTAGE

POWERVENT MODEL NUMBER	VAC	AMPS
RS12 (3', 4', & 5' Models)	120	3.2
RS14 (6', 7' & 8' Models)	120	3.4
RSIF160 (3', 4', & 5' Models)	120	4.9
RSIF180 (6', 7' & 8' Models)	120	7.3

*Amperage listed is the maximum required for the appliance with all options.

Refer to the vent systems manufacturer's installation manual for complete installation instructions. Installation must conform with the venting requirements and restrictions as outlined in this manual. SEE CHART ABOVE FOR SIZE diameter B-Type Venting that must be used. UL/CSA approved B-Vent only. **DO NOT** decrease the vent size.

Vent runs are approved for up to 110 feet with quantity of eleven 90 degree elbows.

Vent runs may also contain a downward component. The downward component may be a maximum of 6 feet plus the distance to the center line of the elbow. See Figure 8A.1.

This will be about 87" for 8" diameter pipe and 92" for 10" diameter pipe.

Due to natural buoyancy of flue gas products, venting downward increases restriction.

Every inch of vertical drop counts as triple inches subtracted off the total vent run.

Example: a maximum drop of 92" means the total allowed vent run is decreased by 276" (23')

Once a downward component has been utilized, the vent cannot go upwards again. Moisture may get trapped in the vent pipe.

Important: Be sure to do your own calculations based on the center line dimension given from the pipe manufacture you are using for your installation.

Figure 8A

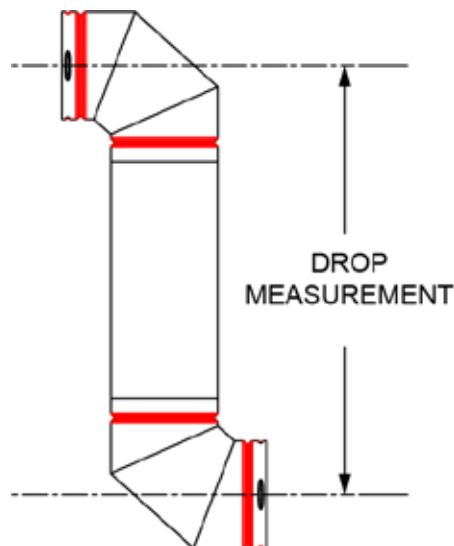

NOTE: All pipe and elbow joints must be sealed. This includes the longitudinal seam on the pipe. High Temp RTV Silicone and/or foil tape **MUST** be used on each joint/seam. Failure to do so may cause lack of vacuum and may not trigger the vacuum switch.

8 - VENTING

D. RS SERIES POWERVENT SPECIFICATIONS

Available Power Venting

A power vent (RS12 & RS14) is approved for use with this appliance. It is crucial that all B-Vent pipe and elbow joints, and the longitudinal seam are sealed using a high temperature RTV Silicone and/or foil tape.

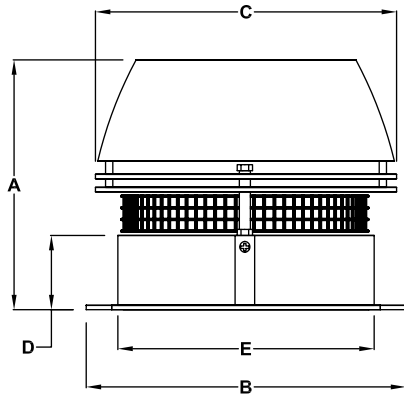

Figure 8A.2

MODEL	RS12	RS14
Fan Type	Axial vane	Axial vane
Motor Type	Totally enclosed, variable speed, Class H	Totally enclosed, variable speed, Class H
Voltage (VAC)	1 x 120	1 x 120
RPM	1600	1600
CFM	950	1400
Amperage (Amps)	1.2	1.4
Motor Output HP (kW)	1/9 (0.08)	1/7 (0.1)
Weight lbs (kg)	37 (17)	47 (21)
Dimension A in. (mm)	11.5 (292)	13.1 (334)
Dimension B x B in.(mm)	14.3 (364)	16.6 (422)
Dimension C in. (mm)	13.5 (344)	15.5 (395)
Dimension D in. (mm)	3.3 (85)	3.9 (100)
Dimension E in. (mm)	11.6 (294)	13.5 (342)
Temperature Rating-Intermittent	575 °F / 300 °C	575 °F / 300 °C
Temperature Rating-Continuous	482 °F / 250 °C	482 °F / 250 °C

E. CHIMNEY COLLAR DIMENSIONS

Chimney Collar Dimensions

A chimney collar is included for use with the RS12 and RS14. The chimney collar is used to attach the RS power vent.

Figures 8A.3 and 8A.4 show the dimensions of the chimney collar.

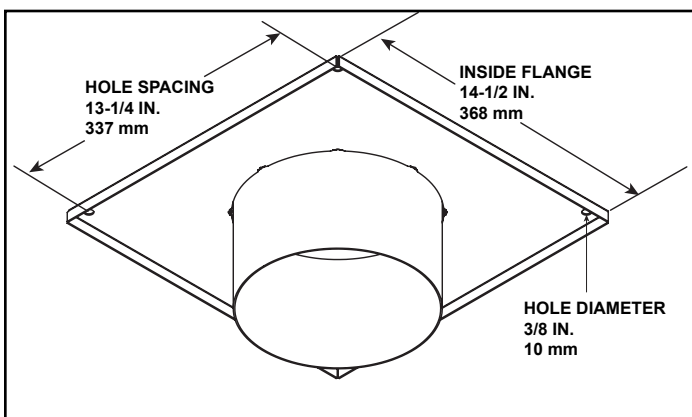

Figure 8A.3 8 Inch Chimney Collar Dimensions (RS12)

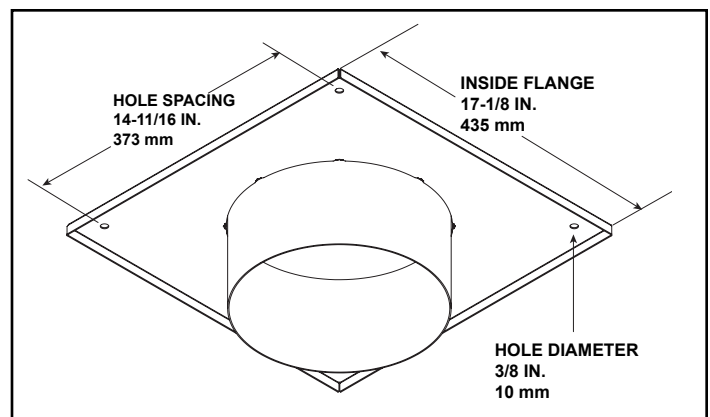

Figure 8A.4 10 Inch Chimney Collar Dimensions (RS14)

8 - VENTING

F. RSIF SERIES POWERVENT SPECIFICATIONS

Available In-Line Power Venting

An in-line power vent (RSIF160 or RSIF180 is approved for use with this appliance. It is crucial that all B-Vent pipe and elbow joints, and the longitudinal seam are sealed using a high temperature RTV Silicone and/or foil tape.

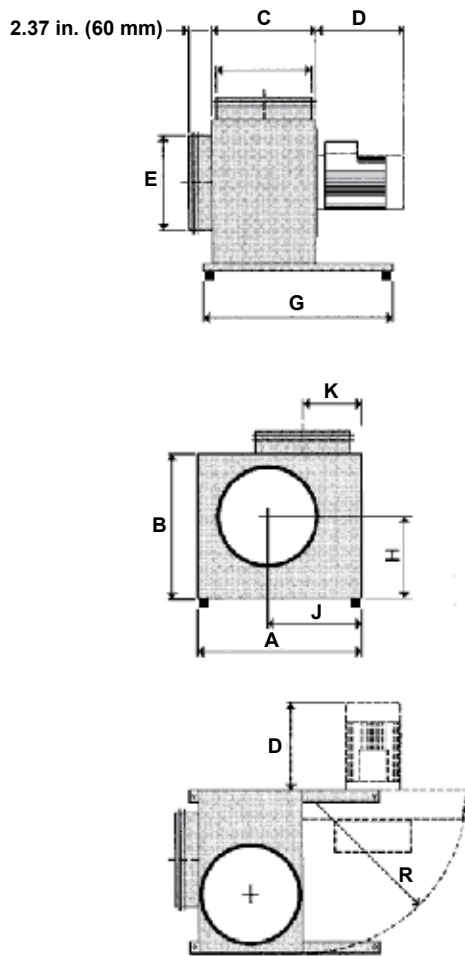

MODEL		RSIF160	RSIF180
Fan Type		Centrifugal Impeller (F-Wheel)	Centrifugal Impeller (F-Wheel)
Motor Type		TEFC	TEFC
Voltage (VAC)		1 x 120	1 x 120
Amperage Amps		2.9	5.3
Motor Output hp (kW)		3/7 (.32)	13/16 (.61)
RPM		1600	1600
Weight lbs (kg)		38 (17)	60 (27)
Duct Connection (E) in. (mm)		8 (203)	8 (203)
Dimension A in. (mm)		14.57 (370)	16.15 (410)
Dimension B in. (mm)		12.60 (320)	13.98 (355)
Dimension C in. (mm)		9.26 (235)	9.26 (235)
Dimension D in. (mm)		5.52 (140)	7.68 (195)
Dimension E in. (mm)		7.9 (200)	7.9 (200)
Dimension G in. (mm)		15.75 (400)	15.75 (400)
Dimension H in. (mm)		7.10 (180)	7.88 (200)
Dimension J in. (mm)		8.27 (210)	9.26 (235)
Dimension K in. (mm)		5.12 (130)	5.12 (130)
Dimension R in. (mm)		14.57 (370)	16.15 (410)

Figure 8A.5

Optional Universal Exhaust and Outdoor Air-Intake Louver information found in Section 9 (Venting Options)

G. IN-LINE POWERVENT PREPARATIONS- RSIF 180

Perform the following steps when installing the RSIF180 on 6', 7' & 8' models.

1. Attach the provided 10 inch B-Vent collar to the intake side of the powervent. The intake side is located opposite the fan motor as shown in Figure 8G.1. The 10 inch B-Vent collar is packaged separately from the powervent. See Figure 8G.2.
2. Note the silhouette circle printed on the intake side of the powervent. The pre-drilled screw holes within the circle will be matched with the holes on the intake collar of the base plate. See Figure 8G.3.
3. Place the intake collar base plate onto the silhouette, matching up the holes as shown in Figure 8G.4. Fasten the base plate to the silhouette using five self-tapping screws.
4. Add the rope gasket included with the kit to the outlet side of the inline powervent.
5. An adapter to increase from eight inch pipe to ten inch pipe is required on the outlet side of the in-line powervent. The adapter is included in the RSIF180 kit. See Figure 8G.5. Connect the adapter directly to the eight inch outlet collar of the in-line powervent. Connect the ten inch exhaust B-Vent to the collar and continue the vent run.

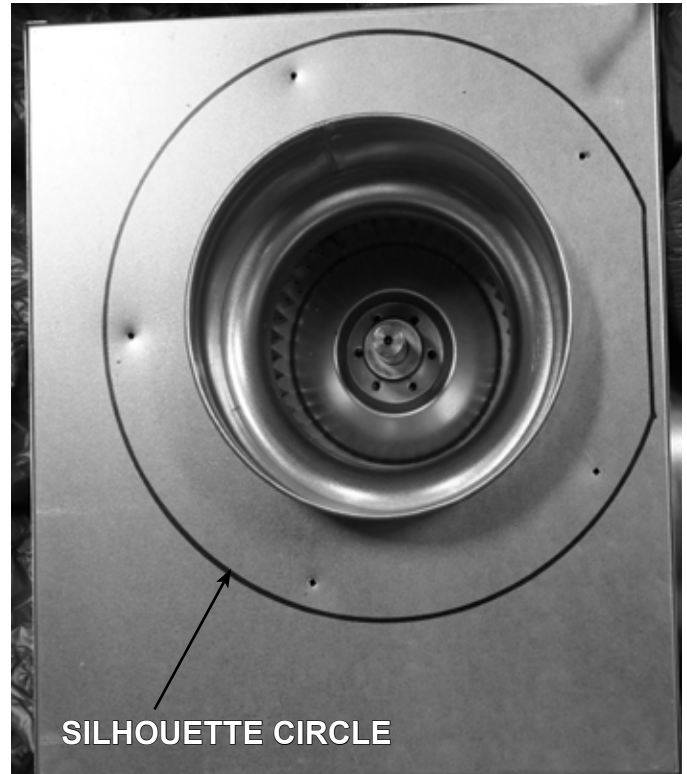

Figure 8G.3 Silhouette Circle on Intake

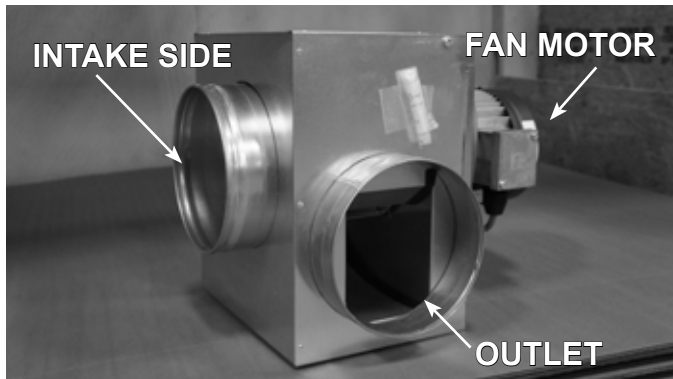

Figure 8G.1 In-Line Powervent (RSIF180)

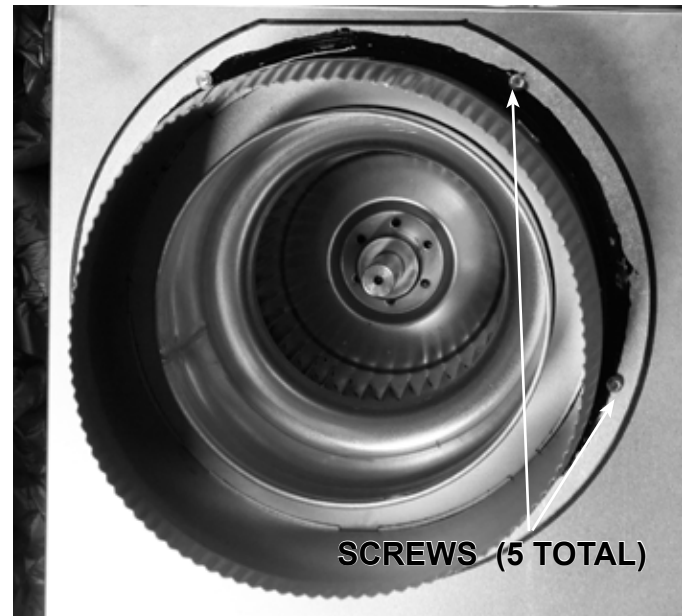

Figure 8G.4 Base Plate Fastened to Intake

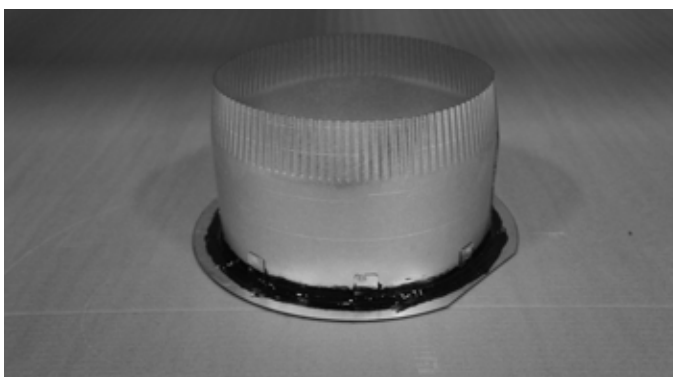

Figure 8G.2 Ten Inch B-Vent Collar



Figure 8G.5

8 - VENTING

H. HORIZONTAL VENT SYSTEM CLEARANCES

ALL APPROVED VENTING	TOP	BOTTOM	SIDES
HORIZONTAL	1 inch [25mm]	1 inch [25mm]	1 inch [25mm]

I. WALL PASS-THROUGH - Follow all local codes for requirement of firestops.

8 - VENTING

J. PITOT TUBE INFORMATION

There is a 1/4" pitot tube mounted in the center of the flue collar and is connected to the pressure switch. (Figure 8E)
This monitors the pressure in the flue and is necessary for proper operation.
Take care to keep the end of the tube clean.

IMPORTANT: THIS TUBE MUST NOT BE BENT, CLOGGED, REMOVED, OR ALTERED IN ANY WAY.

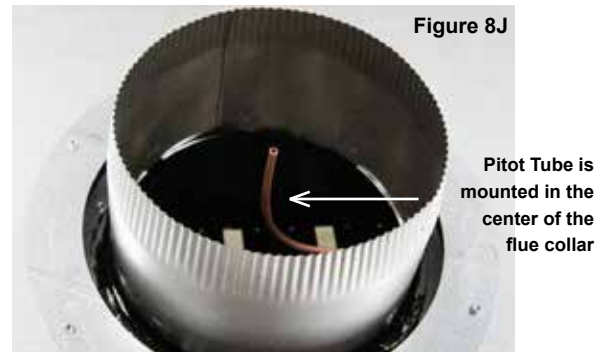

8 - VENTING

K. VERTICAL TERMINATIONS

- The fireplace must terminate with the included approved powered termination cap.
- **NO SUBSTITUTION IS ACCEPTABLE.**
- Carefully follow the instructions included with the approved powered termination cap.
- **DO NOT** use an additional speed control on this powervent.
- You must use the included Capacitor.

L. HORIZONTAL TERMINATION VENT CAP LOCATION & CLEARANCES

This gas appliance must not be connected to a chimney serving any other appliance.

- **DO NOT RECESS TERMINATION KIT INTO OUTSIDE BUILDING MATERIALS** - i.e.: brick, stone, siding, etc. If necessary, extend framing so that termination kit will be exposed once building materials are installed.
- Vent termination must not be located where it will become plugged by snow or other material. The flow of combustion and ventilation air must not be obstructed.

LOCATION CLEARANCES:

- A. Above grade, veranda, porch, deck, balcony - 12 inches [305 mm].
- B. Operable window or door - 12 inches [305 mm].
- C. Permanently closed window* - 12 inches [305 mm] (recommended to prevent condensation on window).
- D. Ventilated soffit* - 24 inches [610 mm].
- E. Unventilated soffit* - 12 inches [305 mm].
- F. Outside corner* - 6 inches [152 mm].
- G. Inside corner* to non-combustibles - 12 inches [305 mm]. Inside corner* to combustibles - 24 inches [610 mm].
- H. Meter / Regulator: Not to be installed above a gas meter/regulator assembly within 3 ft. [914 mm] horizontally from the center-line of the regulator.
- I. Gas Service regulator vent outlet - 3 ft. [914 mm].
- J. Non-mechanical air supply inlet to building or the combustion air inlet to any other appliance.
US: 9" [229 mm] CANADA: 12 inches [305 mm].
- K. Mechanical air supply inlet.
US: 3 ft. [914 mm] above if within 10 ft. [3.05 m] horizontal. Massachusetts installations: 10 ft. [3.05 m].
CANADA: 6 ft. [1.83 m].
- L. Above paved side-walk or paved driveway located on public property - 7 ft. [2.13 m].
- M. Under veranda, porch, deck, or balcony [must be fully opened on a minimum of 2 sides] - Combustible - 24 inches [610 mm],
Non-Combustible - 12 inches [305 mm].
- N. Between two horizontal terminations - 12 inches [305 mm]. (Not shown in Figure 8I).
- O. Between two vertical terminations - 12 inches [305 mm]. Terminations may be same height (Not shown in Figure 8I).
N & O: Minimum of 12 inches [305 mm] required when two exhaust termination caps are placed next to each other. Measurement must be taken from inside edge of one steel chimney adapter to the inside edge of the other steel chimney adapter. A metal divider plate with same length and height as termination cap is required to be installed between the caps. Divider plate is not required if caps are at least 24 inches [610 mm] apart, measured edge to edge.
- P. Above furnace exhaust or inlet - 12 inches [305 mm]. (Not shown in Figure 8I).

*Clearance must be in accordance with local installation codes & the requirements of the gas supplier.



NOTE: A vent cannot be located directly above a side-walk or paved driveway that is located between two single family dwellings and serves both dwellings.

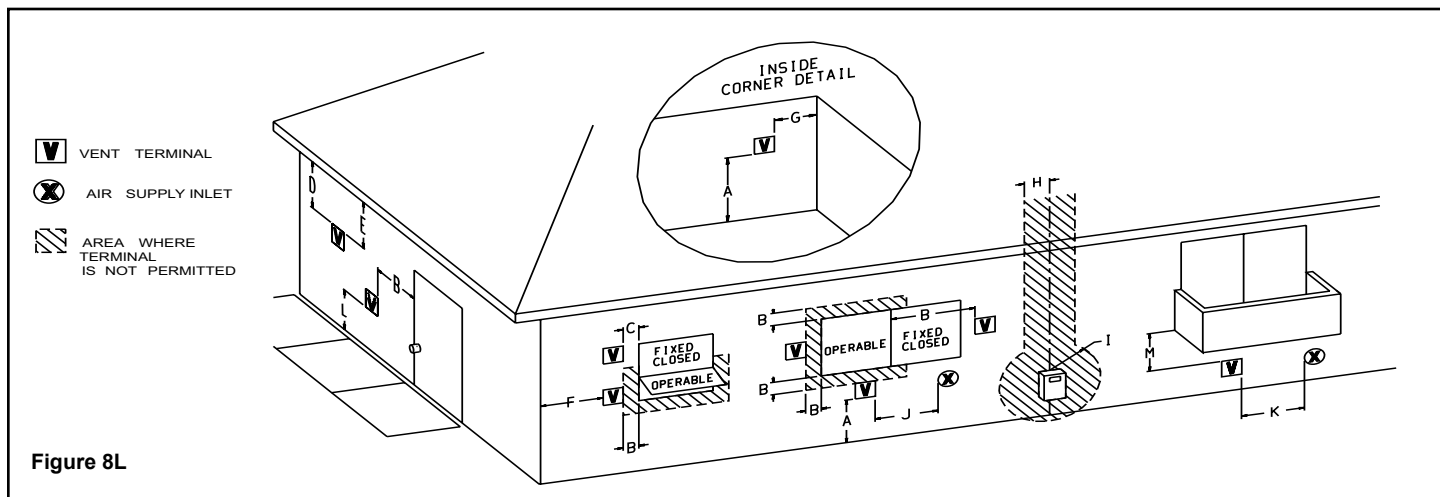
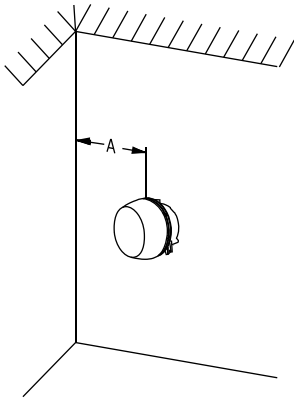

Figure 8L

8 - VENTING

M. HORIZONTAL TERMINATION VENT CAP LOCATION & CLEARANCES

Inside Corner



A = Combustible 24" (609.6mm)
= Non-combustible 12" (304.8mm)

Outside Corner

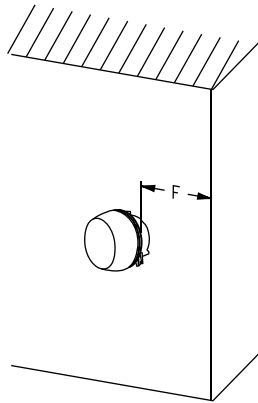

F = Combustible 6" (152mm)
= Non-combustible 6" (152mm)

Recessed Location

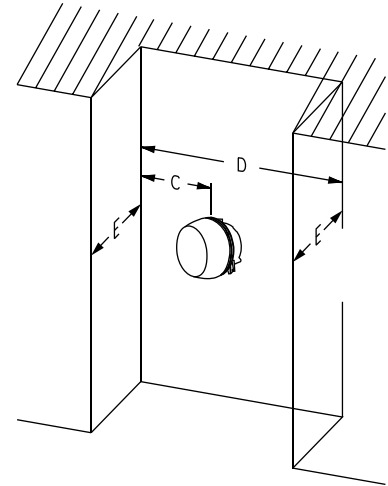

C = Clearance from corner in recessed location
= Combustible 24" (609.6mm)
= Non-combustible 12" (304.8mm)

D = Minimum width for back wall of a recessed location
= Combustible 64" (1,625.6mm)
= Non-combustible 40" (1,016mm)

E = Maximum depth of 48" (1,219mm) for recessed location

Balcony with perpendicular side wall

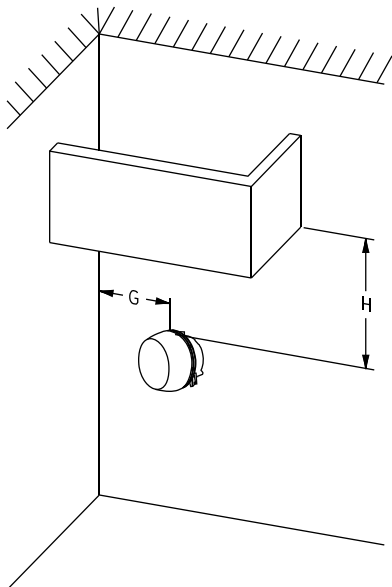

G = Combustible 24" (609.6mm)
= Non-combustible 12" (304.8mm)

H = Combustible 24" (609.6mm)
= Non-combustible 12" (304.8mm)

Balcony with no side wall

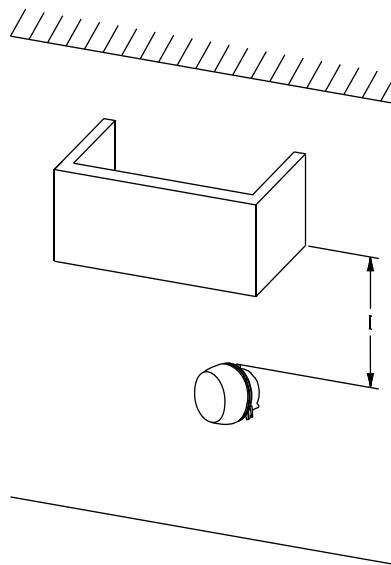

I = Combustible 24" (609.6mm)
= Non-combustible 12" (305mm)

IMPORTANT:
All dimensions are from the edge of the cap.

Figure 8M

8 - VENTING

N. POWERVENT AND AIR-INTAKE PLACEMENT CLEARANCES

RS SERIES POWERVENT

X = Intake
PV = Vent

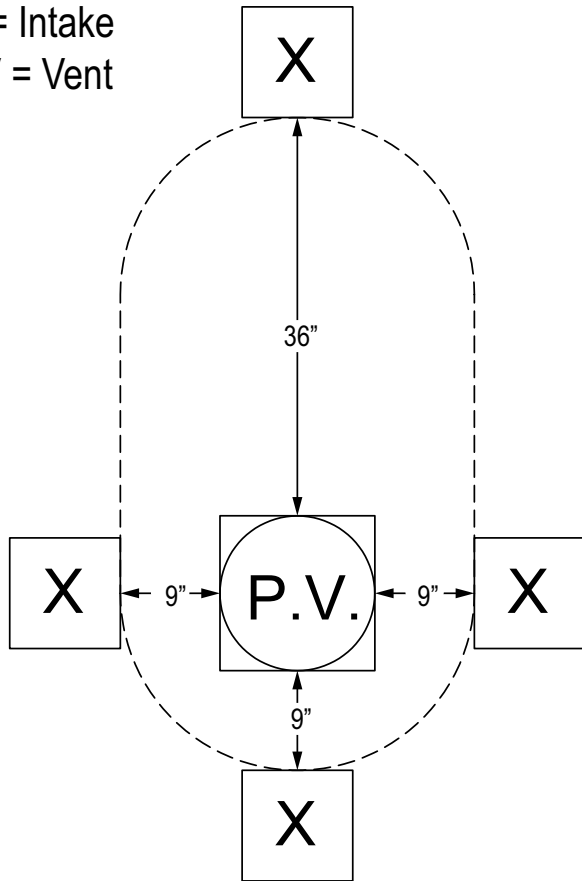

Minimum Clearance Using a RS Series Powervent
Intake Placed Above Vent = 36"
Intake Place To Left Side, Right Side or Below Vent = 9"

Figure 8N.1

IN-LINE POWERVENT (LOUVER 8/10)

X = Intake
PV = Vent

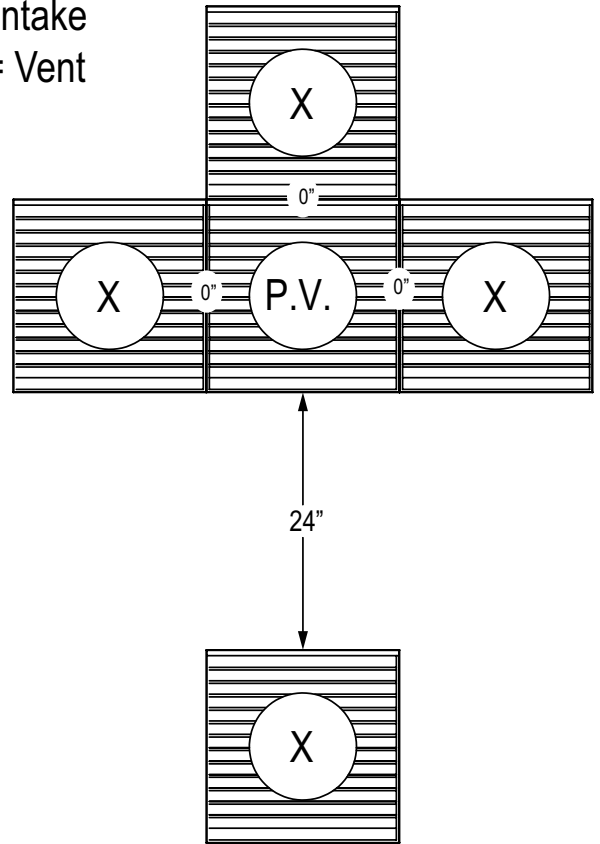

Minimum Clearance Using an In-Line Powevent
Intake Placed Below Vent = 24"
Intake Place To Left Side, Right Side or Above Vent = 0"

Figure 8N.2

8 - VENTING

O. VERTICAL VENT CAP LOCATION AND CLEARANCES

ROOF PITCH	H (Min.) Ft.	H (Min.) M.
FLAT TO 6/12	1.0*	0.30
OVER 6/12 TO 7/12	1.25*	0.38
OVER 7/12 TO 8/12	1.5*	0.46
OVER 8/12 TO 9/12	2.0*	0.61
OVER 9/12 TO 10/12	2.5*	0.76
OVER 10/12 TO 11/12	3.25*	0.99
OVER 11/12 TO 12/12	4.0	1.22
OVER 12/12 TO 14/12	5.0	1.52
OVER 14/12 TO 16/12	6.0	1.83
OVER 16/12 TO 18/12	7.0	2.13
OVER 18/12 TO 20/12	7.5	2.27
OVER 20/12 TO 21/12	8.0	2.44

* = 3 foot minimum in snowy regions

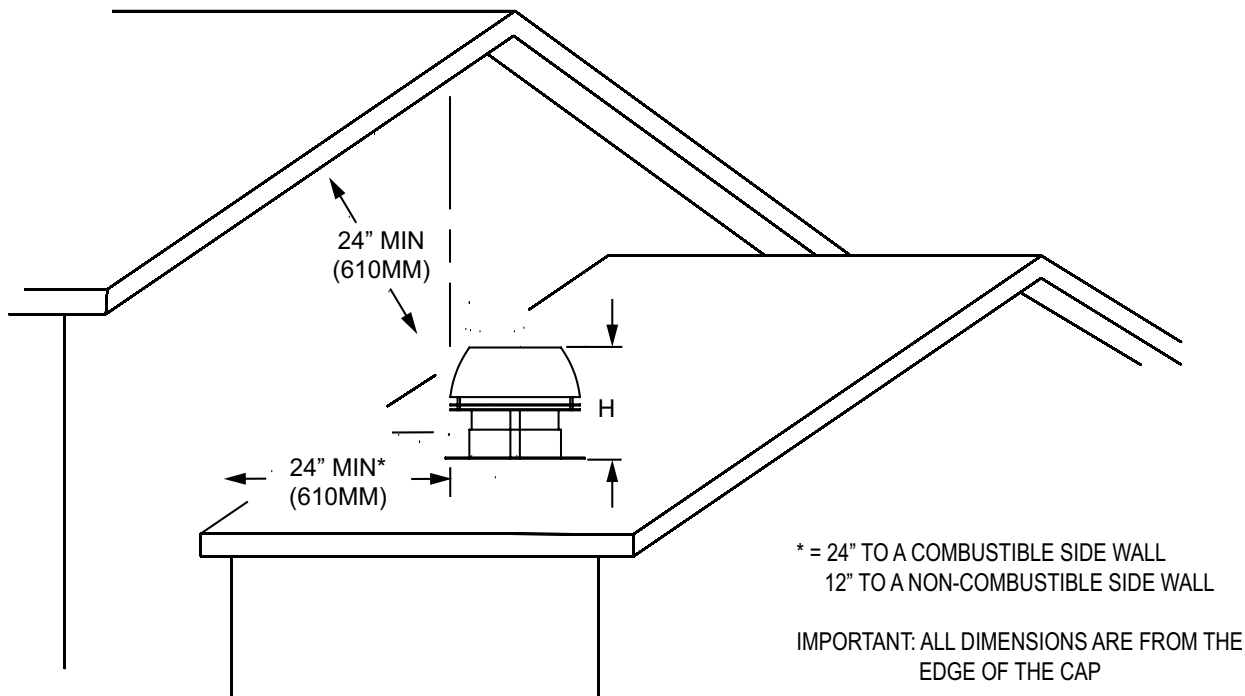

Figure 80

8 - VENTING

P. ROOF TERMINATION CAP INSTALLATION - WITH AND WITHOUT DAMPER

Roof Termination Without Optional Mechanical Damper

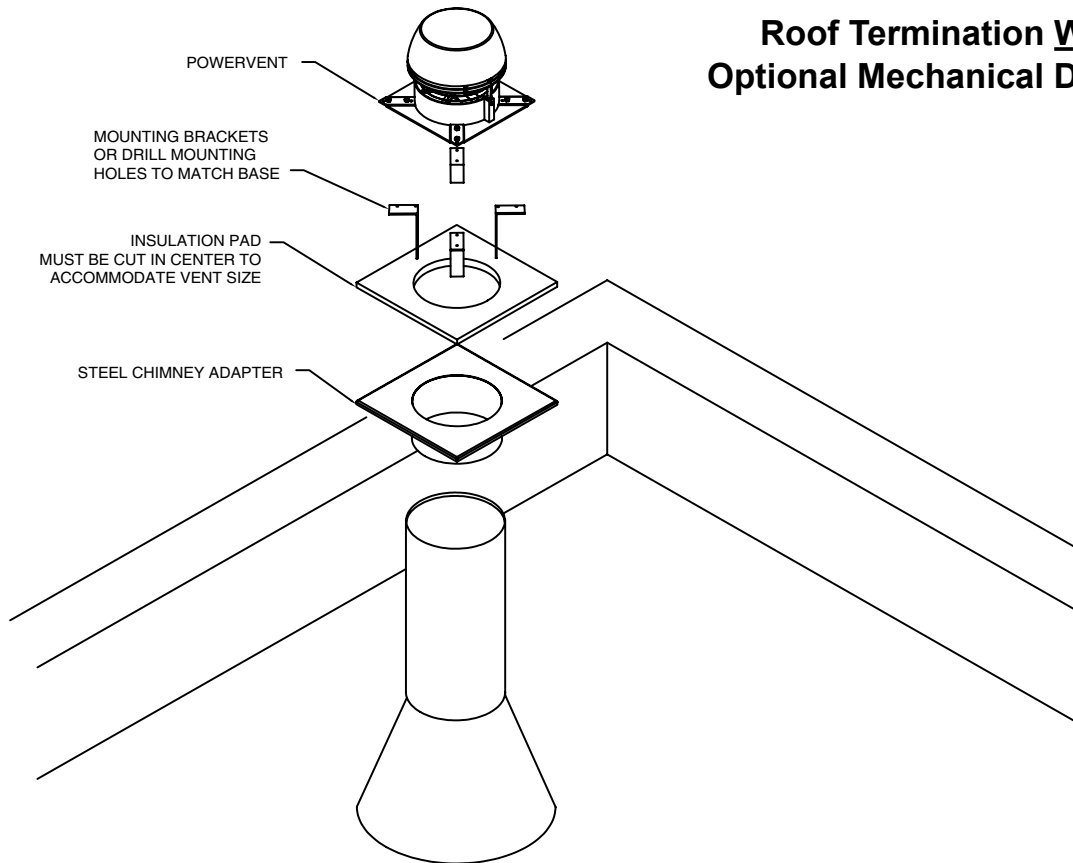

Figure 8P.1

Roof Termination With Optional Mechanical Damper

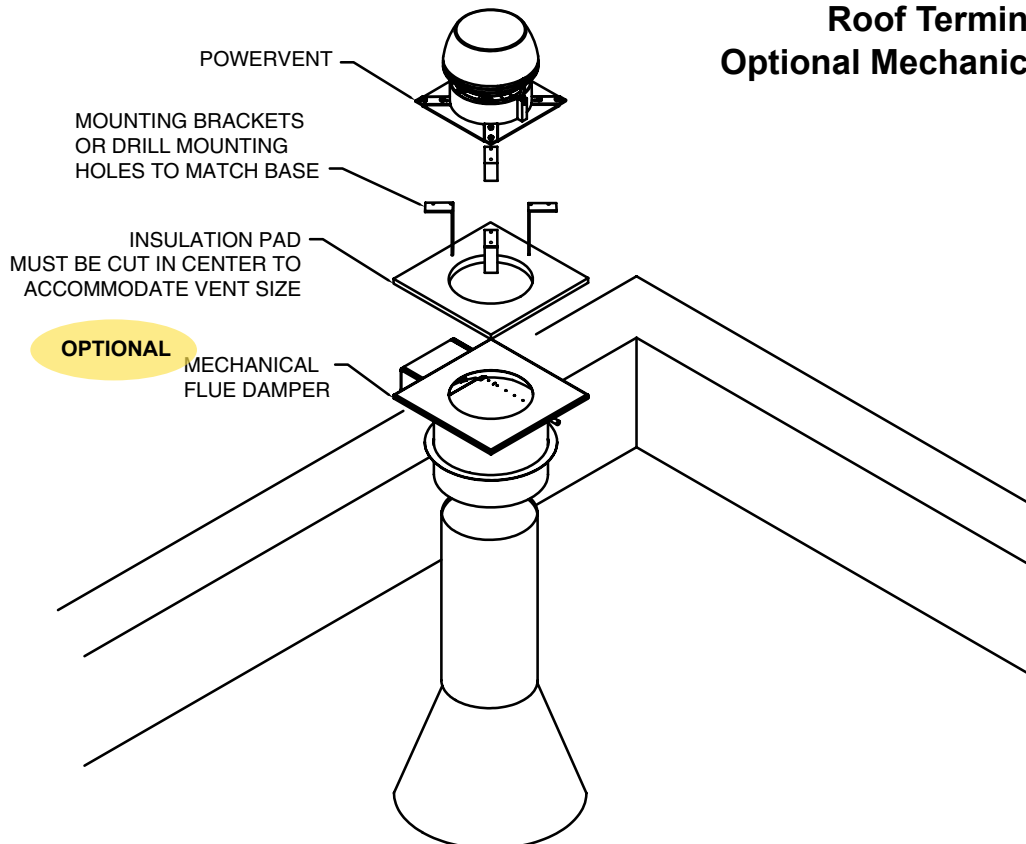

Figure 8P.2

8 - VENTING

Q. WALL TERMINATION - WITH AND WITHOUT DAMPER

Wall Termination Without Optional Mechanical Damper

FRAMING:

8" = 11-3/4" W X 11-3/4" H

10" = 13-1/4" W X 13-1/4" H

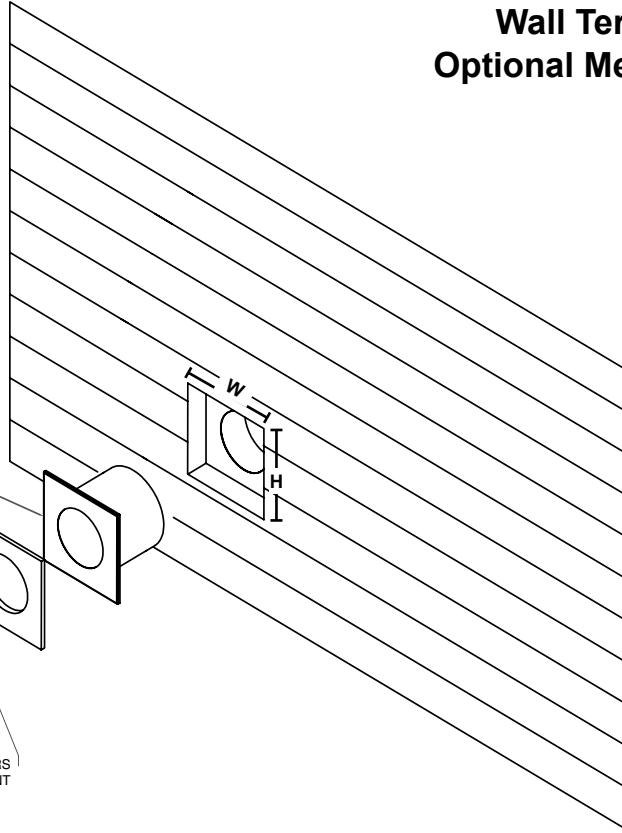
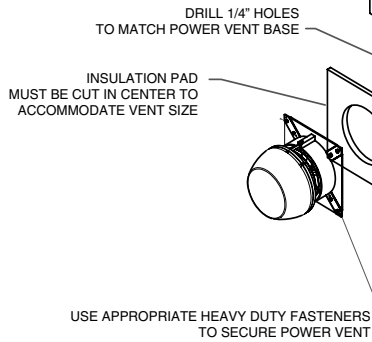

Figure 8Q.1

Wall Termination With Optional Mechanical Damper

OPTIONAL

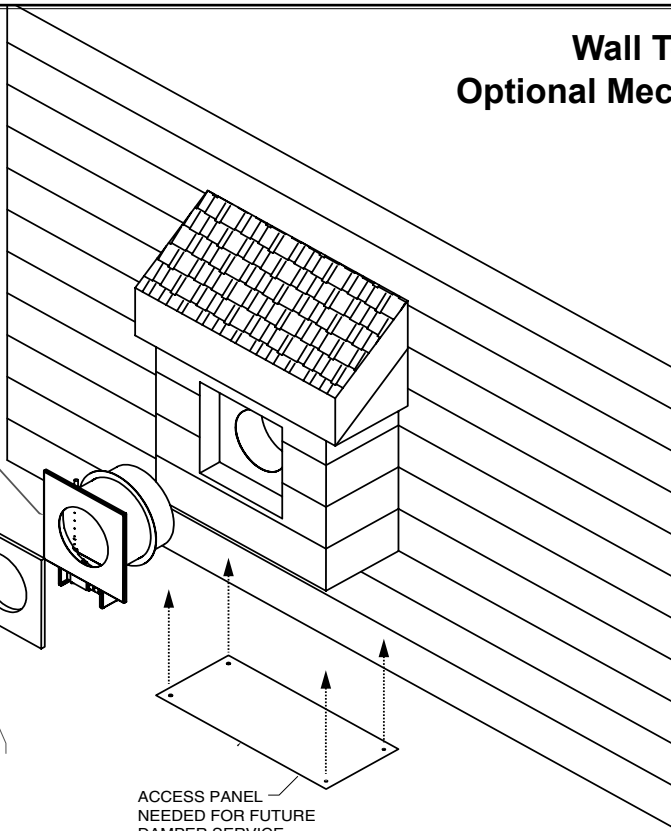
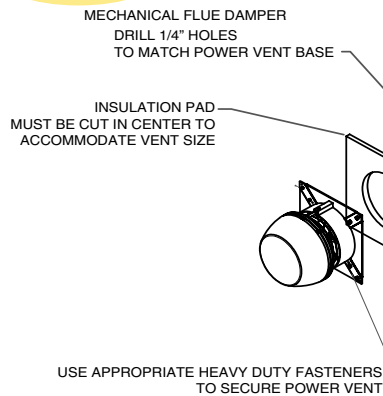

Figure 8Q.2

8 - VENTING

R. OUTDOOR AIR INTAKE

This fireplace has the options of air intake connections on the side or the bottom of the fireplace.

This fireplace is approved for use with 10 inch rigid metal pipe or UL approved 10 inch Class 0 or Class 1 flex for intake air.

Use Table 8R.1 for venting requirements if using UL approved 10 inch flex for intake air.

Vent runs utilizing 10 inch rigid metal pipe may be 110 feet with 11 elbows. We recommend insulating the intake air duct or using UL approved Class 1 insulated flex in hot, humid or cold climates.

The intake pipe must maintain 1.5X the square inches of the flue pipe in free area. Intake screen/vent must be sized appropriately.

Failure to do so will result in higher operating temperatures.

The fireplace may also take room air for combustion. Intake screen/vent must be sized appropriately. You must plan for the replacement air that is consumed from the room by the fireplace. Do not draw intake air from a crawl space or an attic (ventilated or not ventilated).

WARNING! Risk of Fire! DO NOT draw intake air from an attic or crawl space. Appliance could overheat.

Use Table 8R.2 for reference on CFM replacement air if drawing intake air from inside the house and open air requirements for intake screen/vent or consult Hearth & Home Technologies for more information.

Figure 8R.1							
UL Approved Class 1, 10 Inch Insulated Flex Intake Air Venting Requirements							
Fireplace Size	Length Of Run	Number of Offsets FEET [METERS]					
		0-3	4	5	6	7	8
3'	Feet [Meters]	100 [30.5]	90 [27.4]	80 [24.4]	70 [21.3]	60 [18.2]	50 [15.2]
4'		100 [30.5]	90 [27.4]	80 [24.4]	70 [21.3]	60 [18.2]	50 [15.2]
5'	Feet [Meters]	45 [13.7]	35 [10.7]	25 [7.6]	15 [4.6]	5 [1.5]	N/A
6'		70 [21.3]	60 [18.2]	50 [15.2]	40 [12.2]	30 [9.1]	20 [6.1]
7'		32 [9.8]	20 [6.1]	15 [4.6]	10 [3.05]	---	---
8'		12" FLEX	70 [21.3]	60 [18.2]	50 [15.2]	40 [12.2]	30 [9.1]

Figure 8R.2		
CFM Replacement Air		
Fireplace Size	Required CFM	Open Air Requirement
3'	320 CFM	78 Sq. Inches
4'	480 CFM	78 Sq. Inches
5'	640 CFM	78 Sq. Inches
6'	800 CFM	78 Sq. Inches
7'	960 CFM	78 Sq. Inches
8'	1,120 CFM	113 Sq. Inches

S. CHANGING FROM OUTSIDE SIDE INTAKE AIR TO BOTTOM INTAKE AIR

Step 1: Remove 4 screws that hold collar plate in place.

Refer to Figure 8S.1

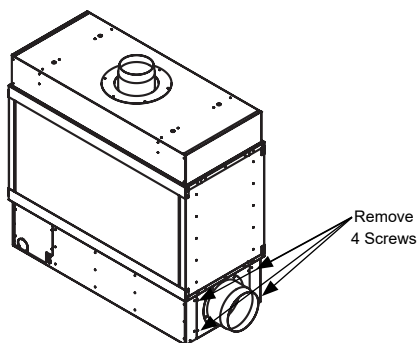

Figure 8S.1

Step 2: Slide collar plate off fireplace.

Refer to Figure 8S.2

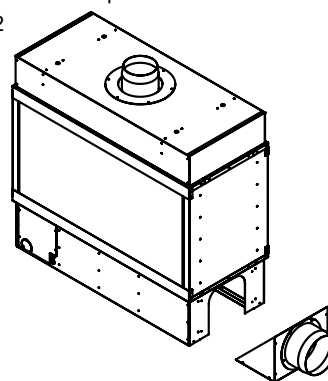

Figure 8S.2

Step 3: Turn plate so collar is facing down, slide plate into slots on each side.

Refer to Figure 8S.3A and Figure 8S.3B

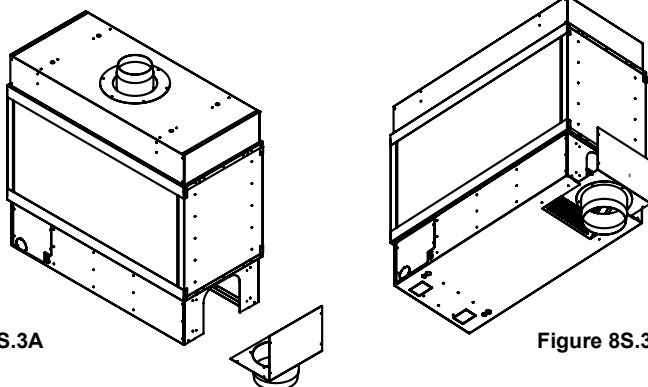

Figure 8S.3A

Figure 8S.3B

Step 4: Re-attach the plate with four screws.

Refer to Figure 8S.4

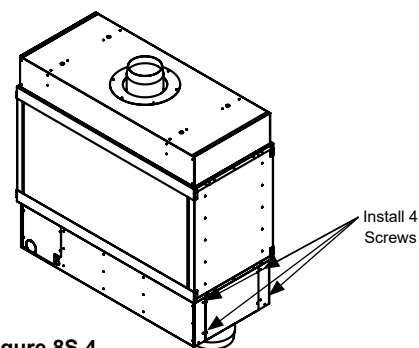

Figure 8S.4

9- VENTING OPTIONS

A. OPTIONAL UNIVERSAL EXHAUST IN AIR-INTAKE LOUVER

MODEL	UNITS	USE
LOUVER-8	3', 4' & 5'	Exhaust and Air-Intake
LOUVER-10	6' & 7'	Exhaust and Air-Intake
LOUVER-12	8	Air-Intake ONLY



This kit is an optional method of terminating the fresh air and/or exhaust for the appliance.

Exhaust terminations must be installed with an inline powervent.

**FOLLOW COMPLETE
INSTALLATION INSTRUCTIONS
PROVIDED WITH THE LOUVER KIT**

LOUVER-8 & LOUVER-10

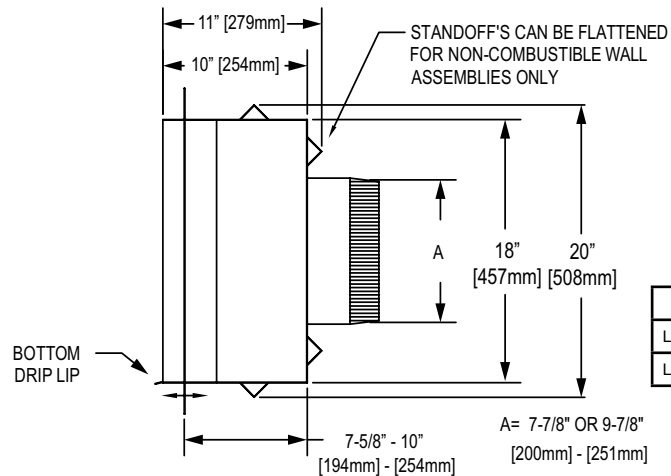
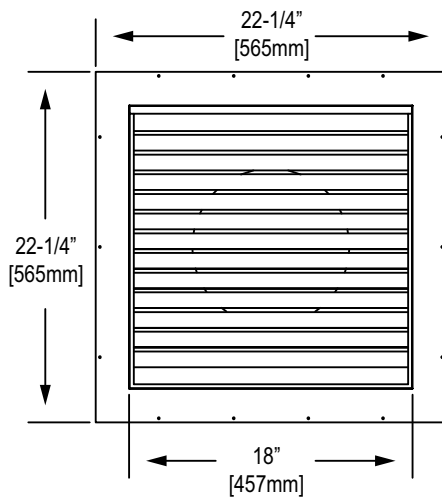

	A
LOUVER-8	7-7/8 IN.
LOUVER-10	9-7/8 IN.

LOUVER-12

AIR-INTAKE ONLY

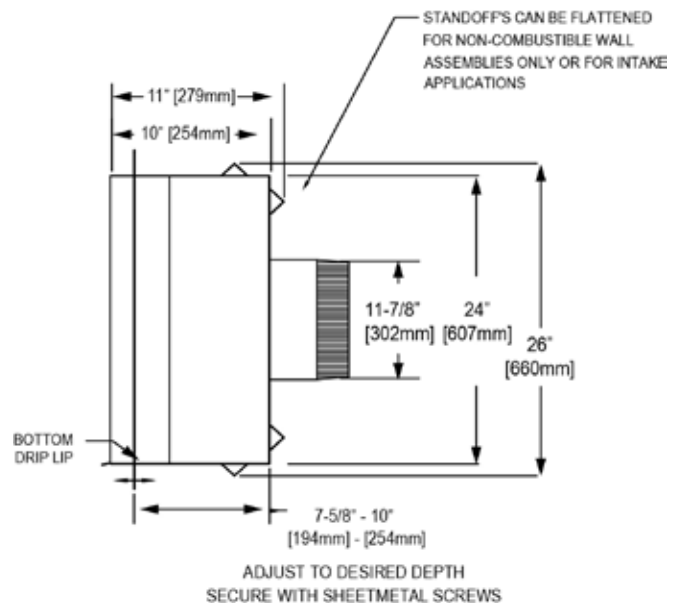
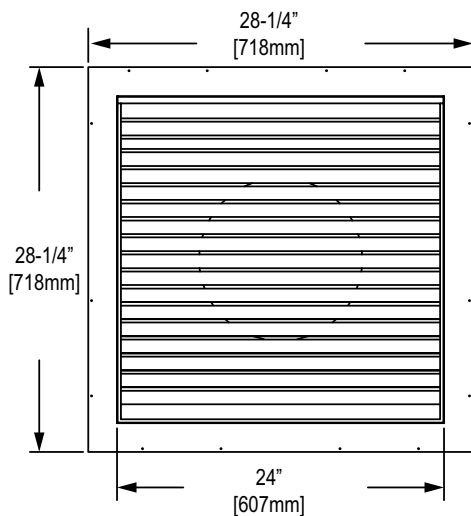

10 - ELECTRIC

A. ELECTRIC - AT INSTALL

Figure 10A Powervent
Voltage Chart

CAP	VAC	AMP	HP
RS12	120	1.2	1/9
RS14	120	1.4	1/7
RSIF160	120	2.9	3/7
RSIF180	120	5.3	13/16

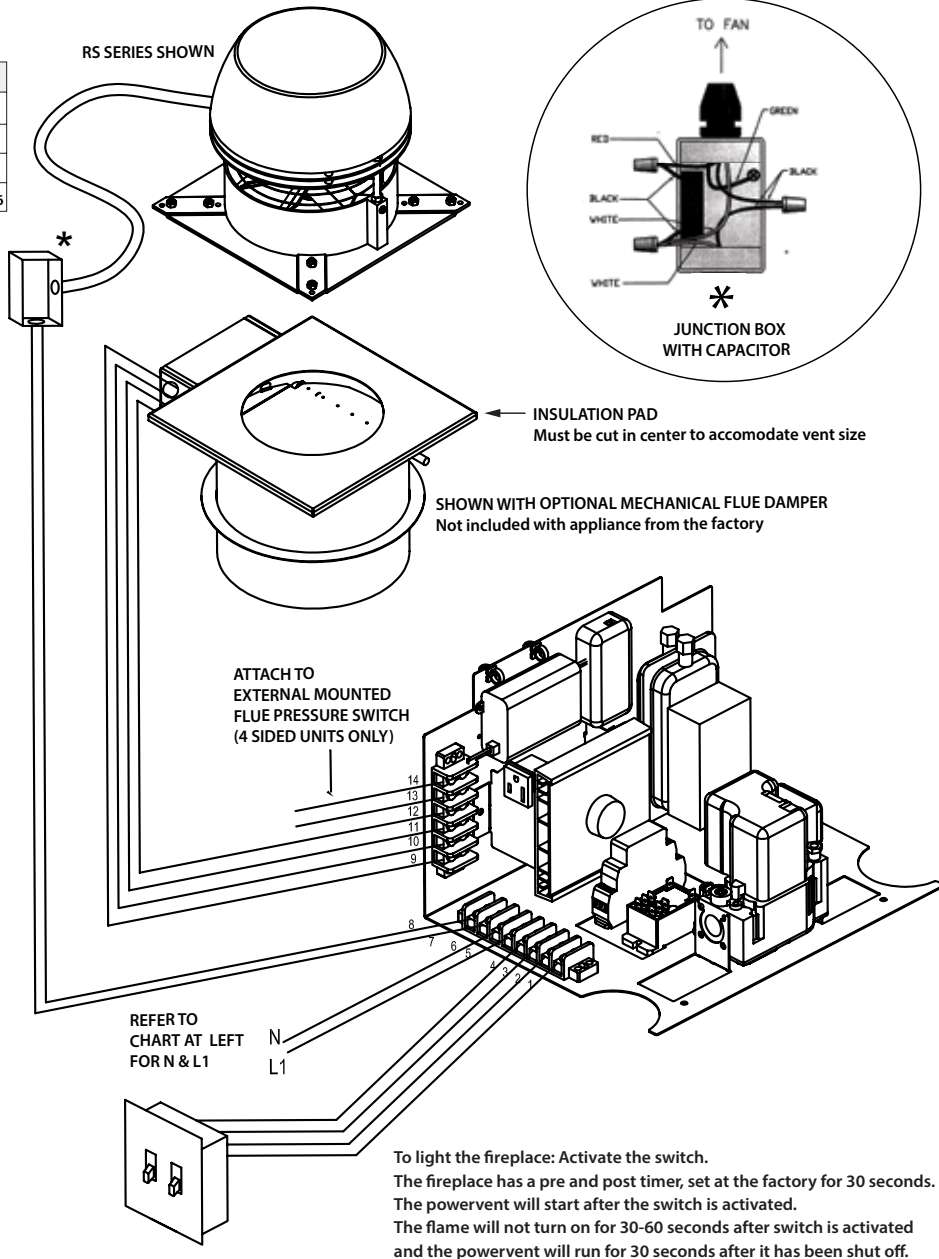

Supply
Voltage Chart (N/L1)

CAP	VAC	AMP
RS12	120	3.2
RS14	120	3.4
RSIF160	120	4.9
RSIF180	120	7.3

To light the fireplace: Activate the switch.
The fireplace has a pre and post timer, set at the factory for 30 seconds.
The powervent will start after the switch is activated.
The flame will not turn on for 30-60 seconds after switch is activated
and the powervent will run for 30 seconds after it has been shut off.

#	FUNCTION	NOTES:
1	120 VAC SW2 LIGHTS	120 VOLT LOOP
2	120VAC SW2 LIGHTS	120 VOLT LOOP
3	120VAC SW1 MAIN FLAME	120 VOLT LOOP
4	120 VAC SW1 MAIN FLAME	120 VOLT LOOP
5	120 VAC SUPPLY	CONNECT TO CONSTANT POWER SOURCE
6	NEUTRAL	CONNECT TO CONSTANT POWER SOURCE
7	NEUTRAL POWERVENT	DO NOT SHARE NEUTRAL
8	120VAC POWERVENT	FROM SPEED CONTROL
9	24VAC FLUE DAMPER POWER	OPTIONAL
10	24VAC FLUE DAMPER NEUTRAL	OPTIONAL
11	SW3 FLUE DAMPER PROVE	OPTIONAL. USE PURPLE AND WHITE, NOT RED
12	SW3 DAMPER PROVE	OPTIONAL. USE PURPLE AND WHITE, NOT RED
13	CONNECTION FOR EXTERNAL FLUE PRESSURE SWITCH (4 SIDED ONLY)	FOUR SIDED ONLY
14	CONNECTION FOR EXTERNAL FLUE PRESSURE SWITCH (4 SIDED ONLY)	FOUR SIDED ONLY

SYSTEM A - LIGHTS

10 - ELECTRIC

C.1 TERMINALS 1 & 2 - LED Lights

TERMINALS 1 AND 2 LED LIGHTING

TERMINAL #2 HAS 120VAC POWER
TO SUPPLY A SWITCH, RELAY, TIMER,
REMOTE, ETC.

TERMINAL #1 RETURNS 120VAC POWER
TO ACTIVATE THE LED DRIVER.

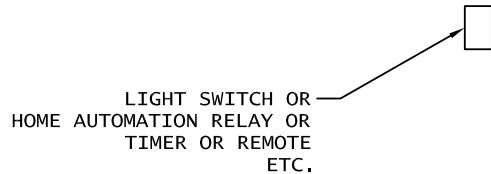
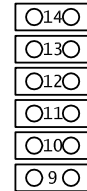

Figure 10C.1 Terminals 1 & 2

C.2 TERMINALS 3 & 4 - Main Flame

TERMINALS 3 AND 4 MAIN FLAME

TERMINAL #4 HAS 120VAC POWER
TO SUPPLY A SWITCH, RELAY, TIMER,
REMOTE, ETC.

TERMINAL #3 RETURNS 120VAC POWER
TO ACTIVATE THE MAIN FLAMES.

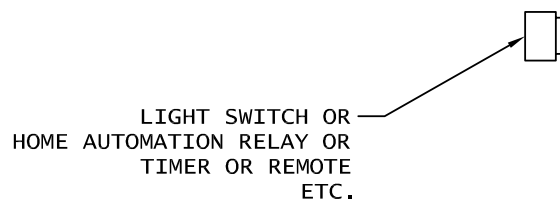
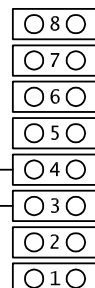
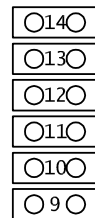

Figure 10C.2 Terminals 3 & 4

10 - ELECTRIC

C.3 TERMINALS 5 & 6 - Fireplace Power

TERMINALS 5 AND 6 FIREPLACE POWER

TERMINAL #5 IS THE 120VAC POWER SUPPLY FOR THE FIREPLACE. THIS IS A CONSTANT POWER SUPPLY AND SHOULD NOT BE SWITCHED. A SERVICE DISCONNECT MAY BE DESIRED.

TERMINAL #6 IS THE NEUTRAL CONNECTION.

GROUND - LOCATE THE GREEN WIRE CLUSTER
CONNECT THE GREEN WIRE TAIL TO BUILDING GROUND

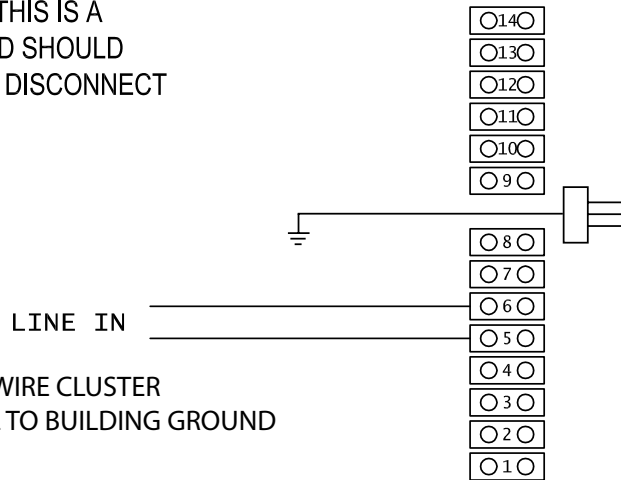
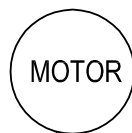

Figure 10C.3
Terminals 5 & 6

C.4 TERMINALS 7 & 8 - Powervent Connection



TERMINAL #7 IS THE NEUTRAL CONNECTION FOR THE POWERVENT MOTOR.

TERMINAL #8 IS THE HOT CONNECTION FOR THE POWERVENT MOTOR FROM THE SPEED CONTROL.

POWERVENT POWER MUST COME FROM THE TERMINAL BLOCK AND NOT ANY OTHER POWER SOURCE.

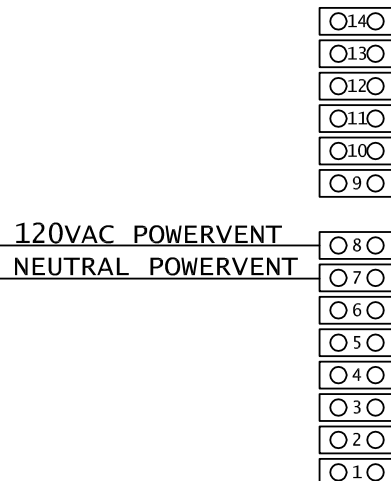

TERMINALS 7 AND 8 POWERVENT CONNECTION

Figure 10C.4
Terminals 7 & 8

10 - ELECTRIC

C.5 TERMINALS 9 & 10 - **OPTIONAL** Flue Damper Connection

Figure 10C.5 Terminals 9 & 10

OPTIONAL

TERMINALS 9 & 10 FLUE DAMPER CONNECTION

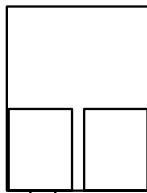

TERMINAL #9 IS THE NEUTRAL CONNECTION
FOR THE DAMPER MOTOR. BLACK WIRE

TERMINAL #10 IS THE HOT CONNECTION FOR THE
DAMPER MOTOR. RED WIRE

THIS IS LOW VOLTAGE AND EXTERNAL POWER
MUST NOT BE APPLIED

24 VAC DAMPER MOTOR - RED
NEUTRAL DAMPER MOTOR - BLACK

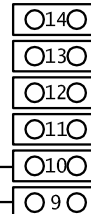

NOTE: OPTIONAL
IF A DAMPER IS NOT USED DO NOT CONNECT
ANYTHING TO TERMINALS 9 & 10



10 - ELECTRIC

C.6 TERMINALS 11 & 12 - **OPTIONAL** Flue Damper Connection

Figure 10C.6 Terminals 11 & 12

OPTIONAL

TERMINALS 11 AND 12
FLUE DAMPER PROVE

NOTE: OPTIONAL
IF A DAMPER IS NOT USED
TERMINALS 11 AND 12 HAVE A JUMPER ACROSS THEM

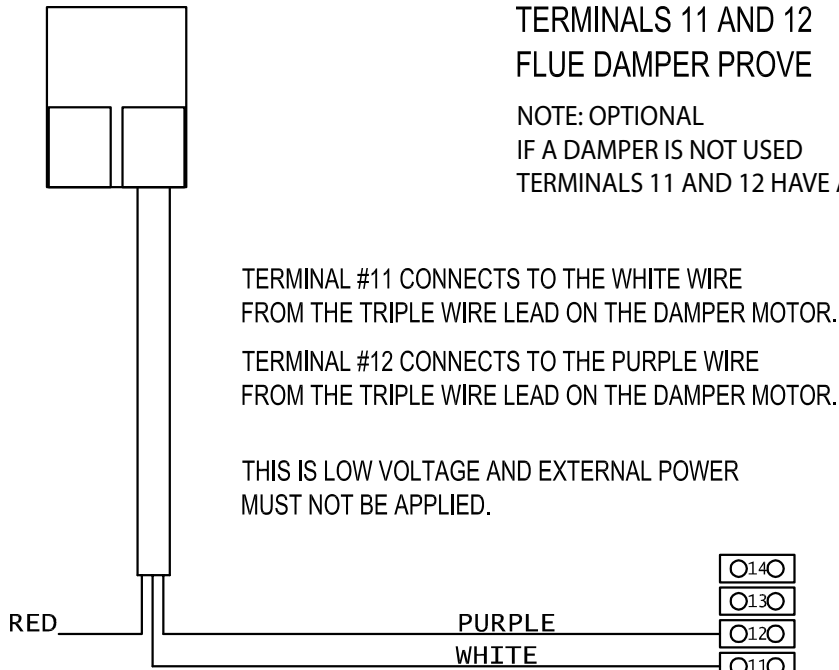

NOTE:
RED IS NOT USED AND SHOULD BE SAFELY CAPPED

○14○
○13○
○12○
○11○
○10○
○9○

○8○
○7○
○6○
○5○
○4○
○3○
○2○
○1○

11 - FINISHING

A.1 FINISHING THE WALL - USING THE PROVIDED 1/2" STANDOFFS



NOTE: REFER TO DIMENSIONS SECTION FOR ALLOWABLE FINISHING DIMENSIONS REQUIRED TO FIT THE GLASS PANELS INTO THE FIREPLACE. FINISHING MATERIALS MUST NOT OVERLAP THE DIMENSIONS HIGHLIGHTED IN GREEN ON PAGE 5. NEVER COVER THE GLASS WITH FINISHING MATERIALS.



NOTE: *DO NOT* BAYCE ANY OF THE BLACK PAINTED SURFACES WITH SCREWS, RIVETS, ETC. THIS INCLUDES THE 3" BLACK TOP AND BOTTOM GLASS TRIM AND ANY PAINTED SIDES ADJACENT TO THE GLASS.



NOTE: REFER TO SECTION 5 MANTEL REQUIREMENTS: NON-COMBUSTIBLE ZONE USING PROVIDED 1/2" STANDOFFS FOR MORE INFORMATION.

Figure 11A.1

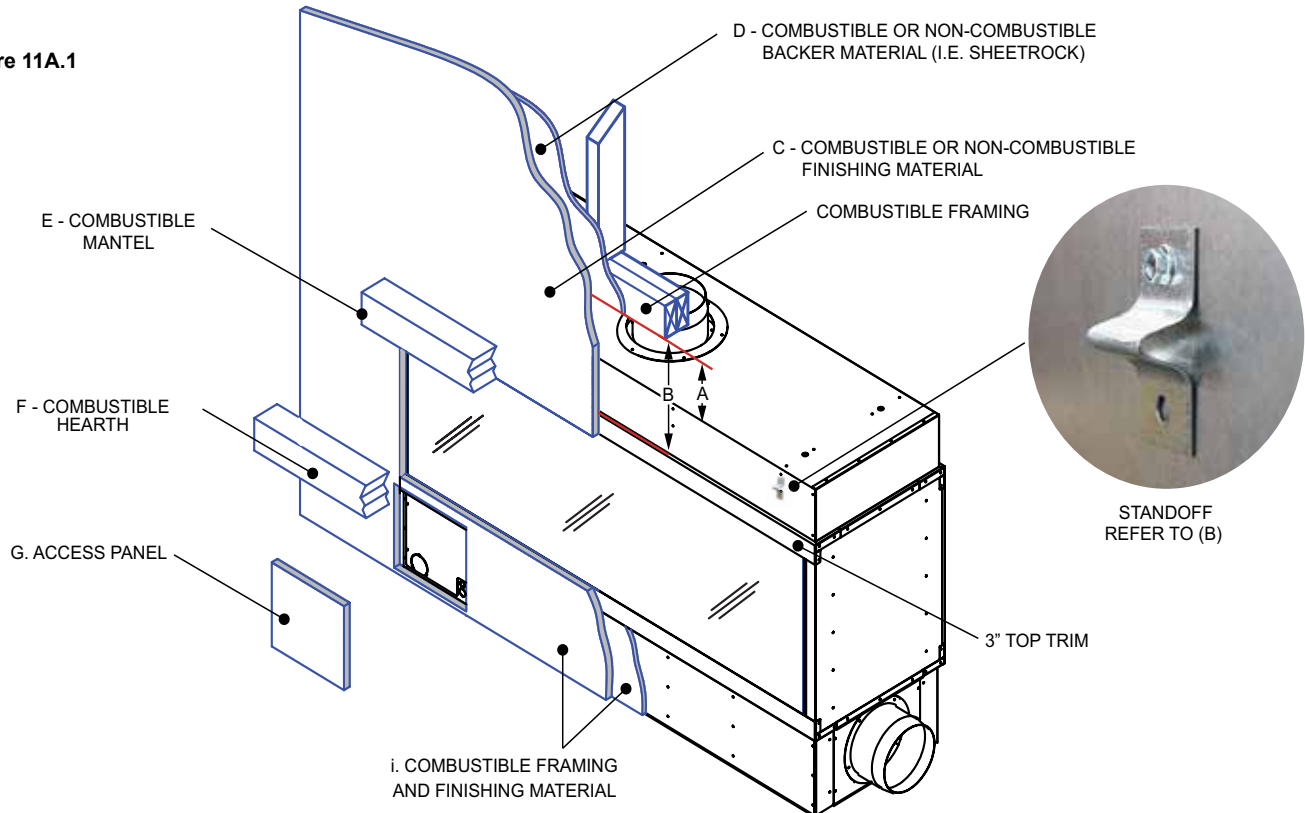

A. No combustible materials may be within 6" [152mm] of the top of the fireplace.

B. 1/2" [12.7] CLEARANCE TO COMBUSTIBLES ON SURFACE. The fireplace ships with standoffs in place to ensure a 1/2" clearance to combustibles is maintained on the surface. See Figure 10A.1. If the standoffs are removed, only non-combustible material can be installed against the surface of the fireplace such as a non-combustible backer cement board. 1/2" [12.7mm] minimum thickness must be used in the space* between the top of the 3" trim to the combustible framing the full width of the fireplace. The space* includes a 7" [178mm] minimum above the top of the fireplace that is recommended for ease of attachment. * = 15" [381] for 3'-7" units and 19" [483] for 8' units.

See Figure 10A.2

C. Combustible material may cover the non-combustible area mentioned in B.

D. Combustible finishing materials allowed.

E. Combustible mantel may be placed above the top of the glass viewing area. There are no restrictions on mantel depth.

F. Combustible hearth may be placed below the bottom of the glass viewing area.

G. Flat covers will cover the components access. Gas and electric inlets are located behind this panel. There are four access panel options all located on the pilot side of the fireplace; front (shown above), side, back and inside behind the glass.

Please take consideration of which option will be used to access the components for service later during planning.

I. Combustible framing and finishing materials allowed.

11 - FINISHING

A.2 FINISHING THE WALL - **NOT** USING THE PROVIDED 1/2" STANDOFFS



NOTE: REFER TO DIMENSIONS SECTION FOR ALLOWABLE FINISHING DIMENSIONS REQUIRED TO FIT THE GLASS PANELS INTO THE FIREPLACE. FINISHING MATERIALS MUST NOT OVERLAP THE DIMENSIONS HIGHLIGHTED IN GREEN ON PAGE 5. NEVER COVER THE GLASS WITH FINISHING MATERIALS.



NOTE: **DO NOT** BAYCE ANY OF THE BLACK PAINTED SURFACES WITH SCREWS, RIVETS, ETC. THIS INCLUDES THE 3" BLACK TOP AND BOTTOM GLASS TRIM AND ANY PAINTED SIDES ADJACENT TO THE GLASS.



NOTE: REFER TO SECTION 5 MANTEL REQUIREMENTS: NON-COMBUSTIBLE ZONE USING PROVIDED 1/2" STANDOFFS FOR MORE INFORMATION.

Figure 11A.2

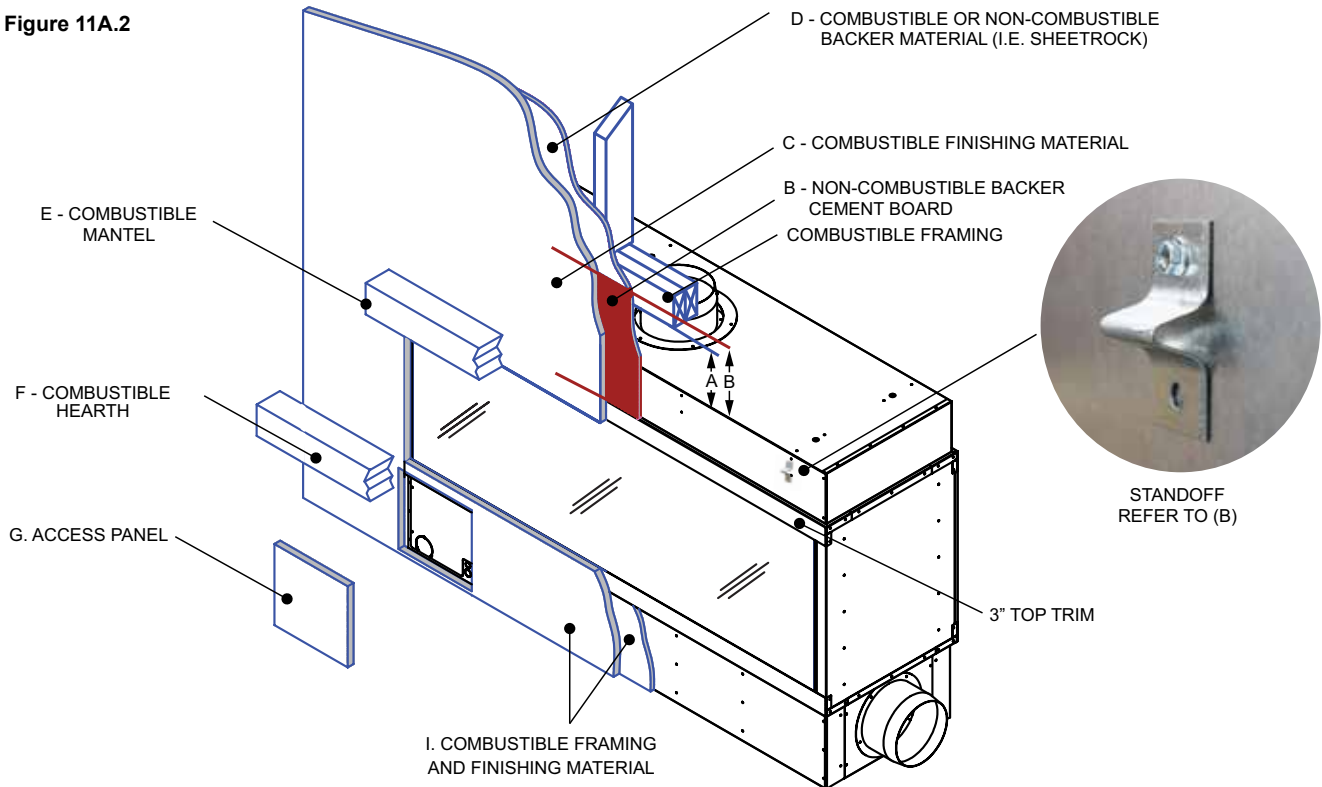

A. No combustible materials may be within 6" [152mm] of the top of the fireplace.

B. 1/2" [12.7] CLEARANCE TO COMBUSTIBLES ON SURFACE. The fireplace ships with standoffs in place to ensure a 1/2" clearance to combustibles is maintained on the surface. See Figure 10A.1. If the standoffs are removed, only non-combustible material can be installed against the surface of the fireplace such as a non-combustible backer cement board. 1/2" [12.7mm] minimum thickness must be used in the space* between the top of the 3" trim to the combustible framing the full width of the fireplace. The space* includes a 7" [178mm] minimum above the top of the fireplace that is recommended for ease of attachment. * = 15" [381] for 3'-7' units and 19" [483] for 8' units. See Figure 10A.2

C. Combustible material may cover the non-combustible area mentioned in B.

D. Combustible finishing materials allowed.

E. Combustible mantel may be placed above the top of the glass viewing area. There are no restrictions on mantel depth.

F. Combustible hearth may be placed below the bottom of the glass viewing area.

G. Flat covers will cover the components access. Gas and electric inlets are located behind this panel. There are four access panel options all located on the pilot side of the fireplace; front (shown above), side, back and inside behind the glass.

Please take consideration of which option will be used to access the components for service later during planning.

I. Combustible framing and finishing materials allowed.

12 - LIGHTING & SHUTDOWN

FOR YOUR SAFETY - READ BEFORE LIGHTING



STOP: IF YOU DO NOT FOLLOW THESE INSTRUCTIONS EXACTLY, A FIRE OR EXPLOSION MAY RESULT, CAUSING PROPERTY DAMAGE, PERSONAL INJURY OR LOSS OF LIFE.

DUE TO HIGH SURFACE TEMPERATURES, KEEP CHILDREN, CLOTHING AND FURNITURE AWAY.

This appliance needs fresh air for safe operation and must be installed so there are provisions for adequate combustion and ventilation air. It is important to make sure the termination cap remains unobstructed at all times from snow, ice, leaves or other debris.

- This fireplace is equipped with an ignition device which automatically lights the pilot and main burner. The pilot and burner light automatically with the wall switch. **DO NOT** try to light the pilot by hand. Before lighting this fireplace, follow these instructions exactly.
- **BEFORE LIGHTING**, smell all around the appliance for gas. Be sure to smell next to the floor because some gas is heavier than air and will settle on the floor.
- Do not use this appliance if any part has been under water. Immediately call a qualified service technician to inspect the appliance and to replace any part of the control system which has been under water.

WHAT TO DO IF YOU SMELL GAS:

- Do not touch any electrical switches
- Do not try to light any appliance
- Do not use the phone in your building
- Immediately call your gas supplier from a neighbor's phone
- Follow the gas supplier's instructions
- If you cannot reach your gas supplier, call the fire department

DO NOT STORE OR USE GASOLINE OR OTHER FLAMMABLE VAPORS AND LIQUIDS IN THE VICINITY OF THIS OR ANY OTHER APPLIANCE



NOTE: A PAINT SMELL WILL OCCUR DURING THE FIRST FEW HOURS OF BURNING.



NOTE: THIS FIREPLACE MAY PRODUCE NOISES OF VARYING DEGREE AS IT HEATS AND COOLS DUE TO METAL EXPANSION AND CONTRACTION. THIS IS NORMAL AND DOES NOT AFFECT THE PERFORMANCE OR LONGEVITY OF THE FIREPLACE.

A. LIGHTING THE FIREPLACE

To light the fireplace:

Activate the switch.

The fireplace has a pre and post timer, set at the factory for 30 seconds.

The powervent will start after the switch is activated.

The flame will not turn on for 30-60 seconds after switch is activated.

The powervent will run for 30 seconds after the fireplace has been shut off.

12 - LIGHTING & SHUTDOWN



STOP! Read safety information on previous page and front cover of this manual before continuing.



NOTE: This fireplace is equipped with an ignition device which automatically lights the pilot. **DO NOT** try to light the pilot by hand.

B. IF THE FIREPLACE DOES NOT LIGHT

1. Turn off the fireplace at switch.
2. Turn off all electrical power to fireplace.
3. Wait five (5) minutes to allow any gas that may have accumulated inside firebox to escape. If you then smell gas, STOP! Follow safety information on front cover and on previous page of the installation manual. If you don't smell gas, go to next step.
4. Turn ON all electrical power to fireplace.
5. Turn fireplace on at switch.

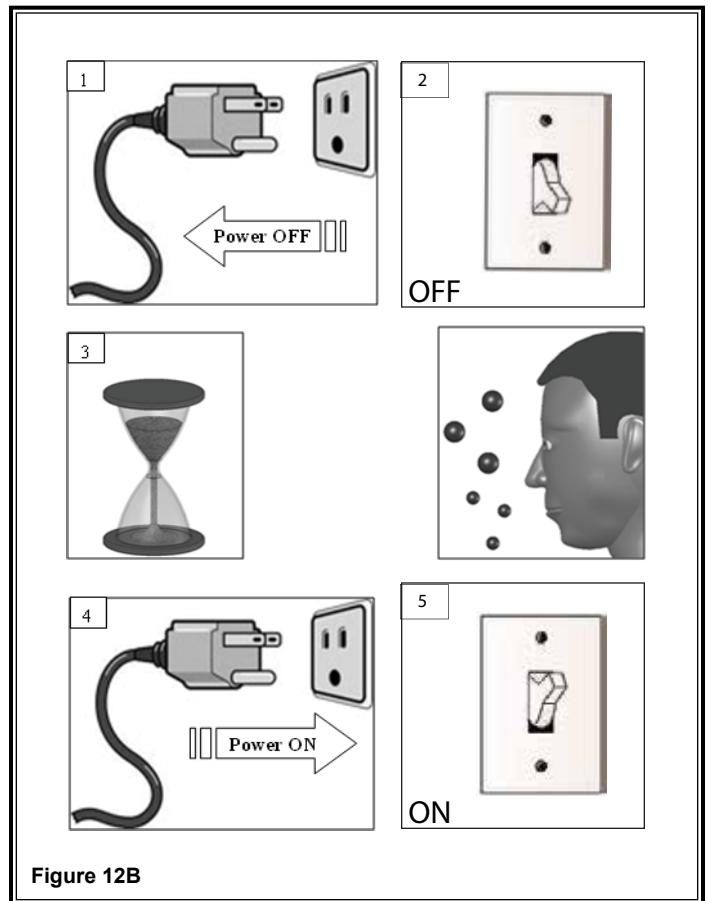

Figure 12B



CAUTION: If fireplace will not operate, follow instructions **TURNING OFF GAS TO FIREPLACE** and call your service technician or the gas supplier.



NOTE: When fireplace is initially lit, condensation may appear on the glass; this is normal in all gas fireplaces and will disappear after several minutes.

13 - PRESSURE TESTING



NOTE: The appliance and its individual shutoff valve must be disconnected from the gas supply piping system during any pressure testing of that system at pressures in excess of ½ psi.



NOTE: The appliance must be isolated from the gas supply piping system by closing its individual manual shut-off valve during any pressure testing of the gas line at test pressures equal to or less than ½ psi (3.5 kPa).

INLET PRESSURE TEST

1. The valve has an allen-plug on the inlet and outlet.
2. Install a barb fitting on the tap you want to measure.
3. Light the fireplace, check the pressure.
4. Turn off fireplace; reinstall plug.
5. Check for leaks.



CAUTION: A LOW PRESSURE READING CAN CAUSE DELAYED IGNITION



NOTE: If inlet pressure reading is too high or too low, contact the gas company. Only a qualified gas service technician should adjust incoming gas pressure.

14 - FINALIZING THE INSTALLATION

A. INSTALLING THE MEDIA

Figure 14A

Place the supplied glass media into the base tray.
Cover the base evenly. Do not use more than the supplied amount.

Do not get any glass media into the pilot area; a hazardous condition could result!

You should be able to see the burner slightly through the media.

DO NOT COVER THE BURNERS; POOR FLAME APPEARANCE WILL RESULT.



Figure 14A

NOTE: DO NOT SUBSTITUTE THE SUPPLIED MEDIA WITH ANY OTHER KIND OF MEDIA WITHOUT WRITTEN APPROVAL OF STELLAR HEARTH PRODUCTS.

B. FLAME APPEARANCE

Flame appearance is affected by several factors including altitude, venting configuration and fuel quality. Although the venturi setting has been factory set, adjustments may be necessary for optimal performance and visual aesthetics.

When fireplace is first lit, the flames will be blue. Flames will gradually turn yellowish-orange during first 15 minutes of operation. If flames remain blue, or become dark orange with evidence of sooting (black tips), the burner tube venturi may need adjustment. Contact Stellar Hearth.

15 - MAINTENANCE

The appliance is required to be inspected at least once a year by a professional service person. The compartment below firebox (behind lower access panel) must be cleaned at least once a year, more frequent cleaning may be required due to excessive lint from carpeting, bedding materials, or other fibrous materials. It is imperative that the burner be cleaned once a year.

VALVE AND ELECTRICAL ACCESS

There is an access panel under the floor of the firebox should more extensive service be needed. Remove the inner and outer glass panels. Remove the glass media on the end with the pilot. The end floor lifts out; remove the screws and lift it out. Remove the burner and loosen the pilot bracket. There is a panel under the floor you removed. Remove the 6 screws and slide the panel up.



NOTE: INSTALLATION AND REPAIR SHOULD BE DONE ONLY BY QUALIFIED SERVICE PERSON. THE APPLIANCE SHOULD BE INSPECTED BEFORE USE AND ANNUALLY BY A QUALIFIED SERVICE PERSON. MORE FREQUENT CLEANING MAY BE REQUIRED DUE TO EXCESSIVE LINT FROM CARPETING, BEDDING MATERIALS, ETC. IT IS IMPERATIVE THAT CONTROL COMPARTMENTS, BURNERS AND CIRCULATION AIR PASSAGeways OF THE APPLIANCE BE KEPT CLEAN.

A. VENT SYSTEM

- Annual examination of venting system by a qualified agency is required.
- IF VENT-AIR INTAKE SYSTEM IS DISASSEMBLED FOR ANY REASON, RE-INSTALL PER INSTRUCTIONS PROVIDED WITH INITIAL INSTALLATION.
- The flow of combustion air must not be obstructed.

B. GLASS CLEANING & REPLACEMENT



WARNING! RISK OF INJURY! DO NOT remove glass until it is cooled to room temperature. Glass breakage could occur. See Section 6 for glass installation and removal instructions.

- Clean glass only when cool and only with non-abrasive cleansers.
- Do not operate this fireplace with glass/frame assembly removed, cracked or broken.
- The glass assembly shall only be replaced as a complete unit.
- Replacement of glass & frame assembly, must only be performed by a licensed or qualified service person. **DO NOT SUBSTITUTE MATERIALS.**
- Do not strike or slam glass door assembly.



NOTE: IN CASE OF CHIPPED OR BROKEN GLASS

Due to the size and sensitivity of shipping the glass separately, it is best to have the replacement glass cut locally if needed. Have your local dealer assist you with contacting Stellar Hearth Products directly to get the proper glass specifications.



CAUTION: LABEL ALL WIRES PRIOR TO DISCONNECTION WHEN SERVICING CONTROLS. WIRING ERRORS CAN CAUSE IMPROPER AND DANGEROUS OPERATION. VERIFY PROPER OPERATION AFTER SERVICING. KEEP APPLIANCE AREA CLEAR OF COMBUSTIBLE MATERIALS, SUCH AS GASOLINE AND OTHER FLAMMABLE VAPORS AND LIQUIDS. VAPORS AND LIQUIDS.

15 - MAINTENANCE

C. REPLACEMENT PARTS LIST

PART	PART NUMBER
Gas Valve - 3' - 7' Units	SV9501
Gas Valve - 8' Units	SV9601
Pilot Assembly	112-5000
Pilot Tube	16400-2851
Replacement Ignitor	B13M-1D643C
Orifice, NG #43	16400-2043
Orifice, Propane #55	16400-2055
Vacuum Switch	112-5003
Transformer, 24 VAC	112-5002
Timer Relay	112-5014
Solid State Relay	112-5009
Speed Control, 10 AMP	16400-4000

PART	PART NUMBER
Natural Gas to Propane Gas Conversion Kit - All Sizes	NG2LP
Propane Gas to Natural Gas Conversion Kit - All Sizes	LP2NG

PART	PART NUMBER
Energex Chimney Fan used for 3' - 5' units	RS12
Energex Chimney Fan used for 6' - 8' units	RS14
Energex In-line Chimney Fan used for 3' - 5' units	RSIF160
Energex In-line Chimney Fan used for 6' - 8' units	RSIF180

PART	PART NUMBER	QUANTITY
Crystal Rock, 5 lb bag	2188-851	<u>Varies by model size</u> 3' = 6 bags 4' = 8 bags 5' = 9 bags 6' = 11 bags 7' = 13 bags 8' = 15 bags

PART	PART NUMBER
8 Inch Exhaust Collar - 3'-5' Units	16400-1450
10 Inch Intake/Exhaust Collar - 6'-7' Units	16400-1550
12 Inch Intake Collar - 8' Units	16800-1550
LED Controller	16400-1901
LED Remote Control	16400-1901R
LED Transformer, 12VDC	16400-1900
Switch, 15 Amp Toggle	16400-3013
2-Gang Electrical Box	16400-3014
White Nylon 2-Gang Plate	16400-3015
Suction Cup	675-9605
8 Inch Powervent Chimney Collar	117-001
10 Inch Powervent Chimney Collar	117-002

PART	PART NUMBER
Replacement Capacitor - RS12	601.0400.0064
Replacement Capacitor - RS14	604.0400.0064
Replacement Capacitor - RSIF160	604.0600.0064
Replacement Capacitor -RSIF180	604.0800.0064

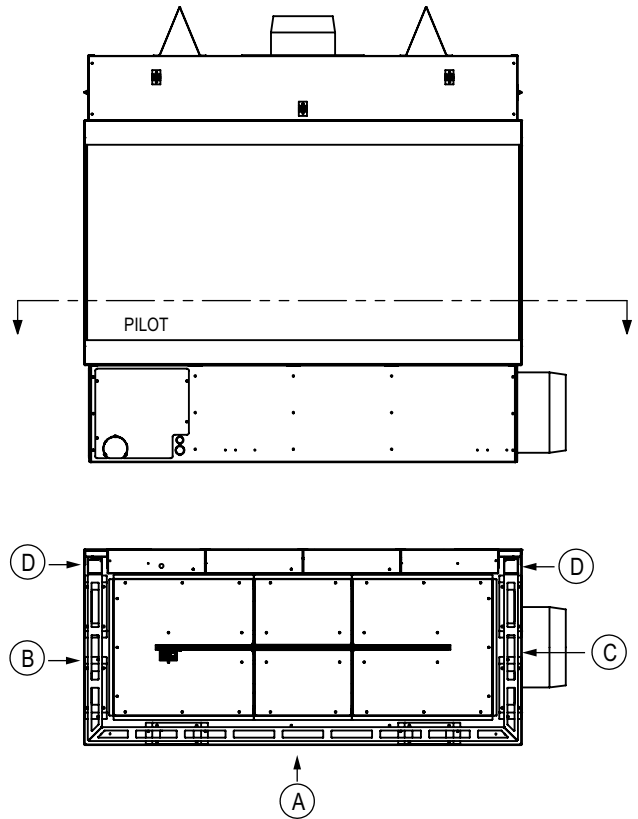

Figure 15C

15 - MAINTENANCE

TRIM BETWEEN INNER AND OUTER GLASS - REFER TO FIGURE 15C

MODEL	D = Vertical Trim Pieces		A = Horizontal Trim Pieces Between Glass - Front		B = Horizontal Trim Pieces Between Glass - Left Side		C = Horizontal Trim Pieces Between Glass - Right Side	
	Part #	Qty	Part #	Qty	Part #	Qty	Part #	Qty
3BY-20GL	SRV16400-1433	2	SRV16300-1044	1	SRV16400-1145	1	SRV16400-1245	1
3BY-24GL	SRV16400-1033	2	SRV16300-1044	1	SRV16400-1145	1	SRV16400-1245	1
3BY-30GL	SRV16400-1633	2	SRV16300-1044	1	SRV16400-1145	1	SRV16400-1245	1
3BY-36GL	SRV16400-1833	2	SRV16300-1044	1	SRV16400-1145	1	SRV16400-1245	1
3BY-48GL	SRV16400-1533	2	SRV16300-1044	1	SRV16400-1145	1	SRV16400-1245	1
3BY-60GL	SRV16400-1933	2	SRV16300-1044	1	SRV16400-1145	1	SRV16400-1245	1
4BY-20GL	SRV16400-1433	2	SRV16400-1044	1	SRV16400-1145	1	SRV16400-1245	1
4BY-24GL	SRV16400-1033	2	SRV16400-1044	1	SRV16400-1145	1	SRV16400-1245	1
4BY-30GL	SRV16400-1633	2	SRV16400-1044	1	SRV16400-1145	1	SRV16400-1245	1
4BY-36GL	SRV16400-1833	2	SRV16400-1044	1	SRV16400-1145	1	SRV16400-1245	1
4BY-48GL	SRV16400-1533	2	SRV16400-1044	1	SRV16400-1145	1	SRV16400-1245	1
4BY-60GL	SRV16400-1933	2	SRV16400-1044	1	SRV16400-1145	1	SRV16400-1245	1
5BY-20GL	SRV16400-1433	2	SRV16500-1044	1	SRV16400-1145	1	SRV16400-1245	1
5BY-24GL	SRV16400-1033	2	SRV16500-1044	1	SRV16400-1145	1	SRV16400-1245	1
5BY-30GL	SRV16400-1633	2	SRV16500-1044	1	SRV16400-1145	1	SRV16400-1245	1
5BY-36GL	SRV16400-1833	2	SRV16500-1044	1	SRV16400-1145	1	SRV16400-1245	1
5BY-48GL	SRV16400-1533	2	SRV16500-1044	1	SRV16400-1145	1	SRV16400-1245	1
5BY-60GL	SRV16400-1933	2	SRV16500-1044	1	SRV16400-1145	1	SRV16400-1245	1
6BY-20GL	SRV16400-1433	2	SRV16600-1044	1	SRV16400-1145	1	SRV16400-1245	1
6BY-24GL	SRV16400-1033	2	SRV16600-1044	1	SRV16400-1145	1	SRV16400-1245	1
6BY-30GL	SRV16400-1633	2	SRV16600-1044	1	SRV16400-1145	1	SRV16400-1245	1
6BY-36GL	SRV16400-1833	2	SRV16600-1044	1	SRV16400-1145	1	SRV16400-1245	1
6BY-48GL	SRV16400-1533	2	SRV16600-1044	1	SRV16400-1145	1	SRV16400-1245	1
6BY-6GL	SRV16400-1933	2	SRV16600-1044	1	SRV16400-1145	1	SRV16400-1245	1
7BY-20GL	SRV16400-1433	2	SRV16700-1044	1	SRV16400-1145	1	SRV16400-1245	1
7RC-24G	SRV16400-1033	2	SRV16700-1044	1	SRV16400-1145	1	SRV16400-1245	1
7BY-30GL	SRV16400-1633	2	SRV16700-1044	1	SRV16400-1145	1	SRV16400-1245	1
7BY-36GL	SRV16400-1833	2	SRV16700-1044	1	SRV16400-1145	1	SRV16400-1245	1
7BY-48GL	SRV16400-1533	2	SRV16700-1044	1	SRV16400-1145	1	SRV16400-1245	1
7BY-60GL	SRV16400-1933	2	SRV16700-1044	1	SRV16400-1145	1	SRV16400-1245	1
8BY-20GL	SRV16400-1433	2	SRV16800-1044	1	SRV16400-1145	1	SRV16400-1245	1
8BY-24GL	SRV16400-1033	2	SRV16800-1044	1	SRV16400-1145	1	SRV16400-1245	1
8BY-30GL	SRV16400-1633	2	SRV16800-1044	1	SRV16400-1145	1	SRV16400-1245	1
8BY-36GL	SRV16400-1833	2	SRV16800-1044	1	SRV16400-1145	1	SRV16400-1245	1
8BY-48GL	SRV16400-1533	2	SRV16800-1044	1	SRV16400-1145	1	SRV16400-1245	1
8BY-60GL	SRV16400-1933	2	SRV16800-1044	1	SRV16400-1145	1	SRV16400-1245	1