

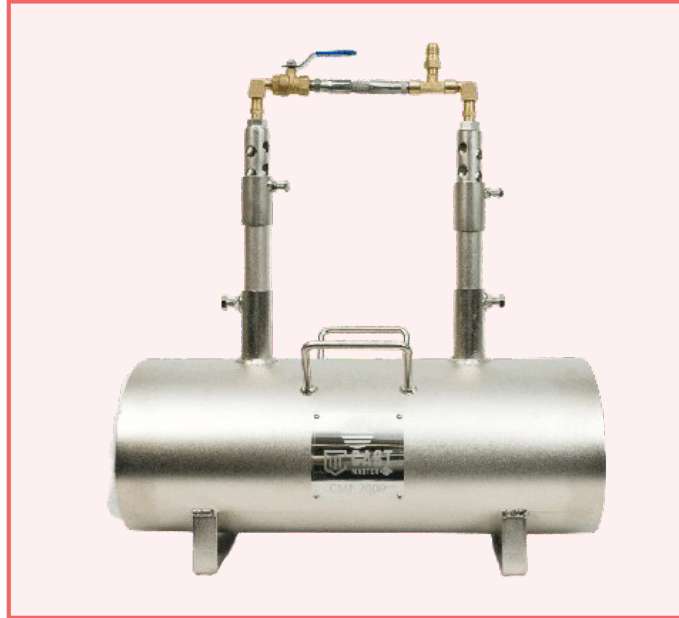

CMF 2000 – Dual
Burner Propane Forge

USER MANUAL



Contact Info

🌐 castmasterelite.com
✉ Info@CastMasterElite.Com

CMF 2000 – OPERATIONAL SAFETY

Your CAST MASTER product is designed to provide safe and efficient operation. Due to the extremely high heat and hot metal involved in this process, a high degree of caution and care are critical to ensure its safe use. Please note the following the precautions before operating this furnace.



WARNING

Always use appropriate safety equipment including:

- Safety glasses
- Fireproof apron
- Heat resistant gloves
- Leather-toed shoes

Hot metal can cause serious injury if not handled properly and carefully.

When operating your product:

- Keep hands, hair and clothing away from chamber
- Do not touch the furnace while in use or until sufficient cooling time has passed
- The forge generates extremely high temperature that can cause severe burns or a fire

CMF 2000 – PARTS LIST

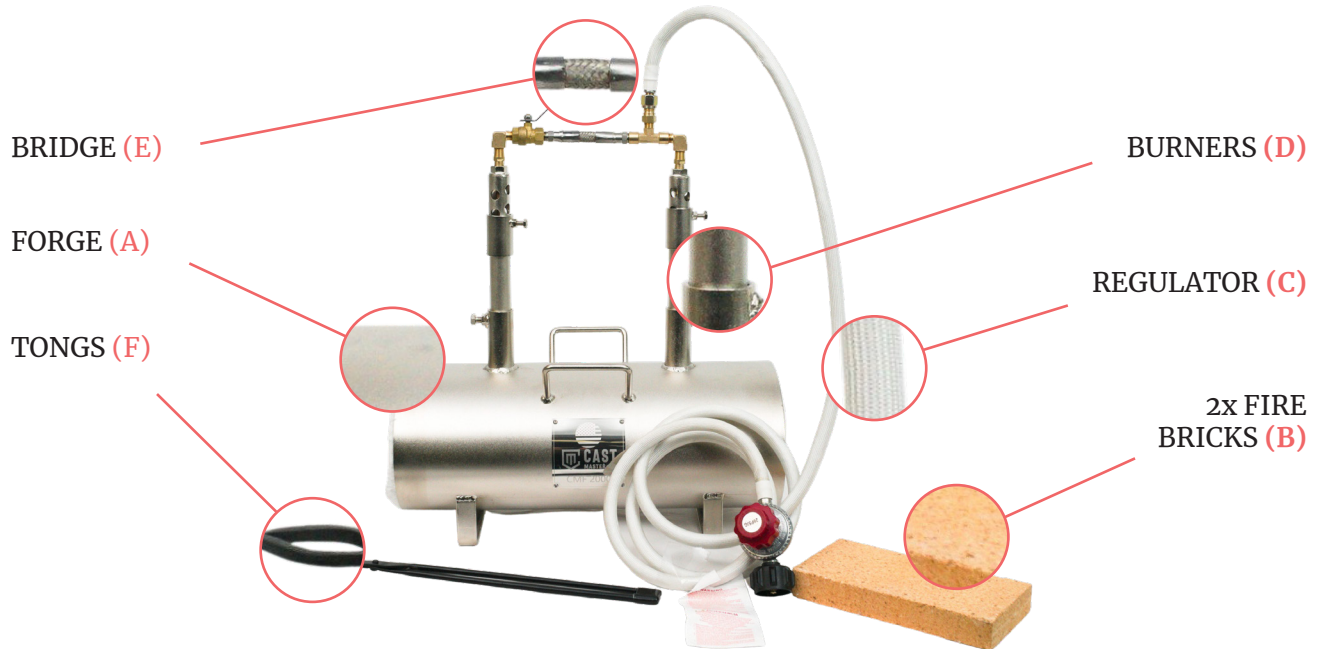

CMF 2000 – ASSEMBLY

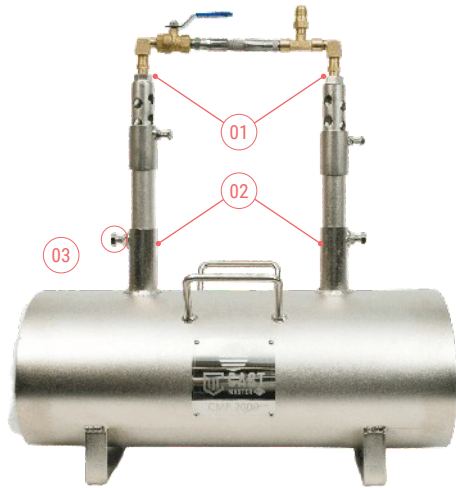

FIGURE 1

01

ASSEMBLE THE BURNERS (D) ON EITHER END OF THE BRIDGE (E)

02

SLIDE THE BURNERS (D) INTO THE TWO OPENINGS ON THE TOP OF THE FORGE (A)

03

LOCK THE BURNERS (D) INTO POSITION USING THE SET SCREWS



AT THIS POINT YOUR ASSEMBLY SHOULD LOOK LIKE FIGURE 1

04

4 ATTACH THE REGULATOR (C) TO THE BRIDGE (E)

05

PLACE FIRE BRICK (B) INSIDE THE FORGE (A)
UNDER EACH BURNER



AT THIS POINT YOUR ASSEMBLY IS COMPLETE AND
SHOULD LOOK LIKE FIGURE 2

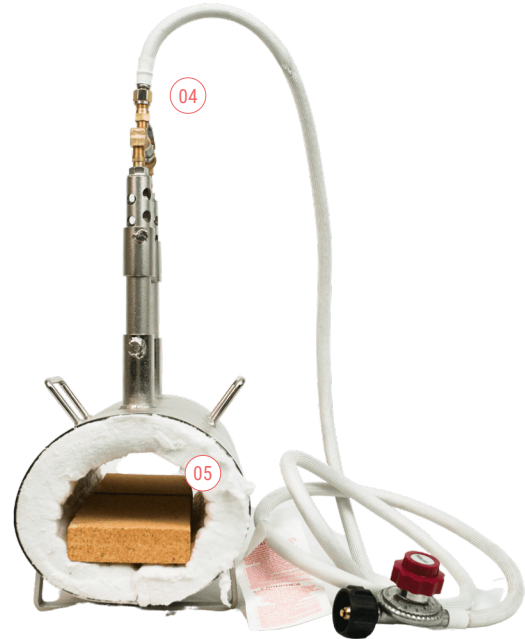
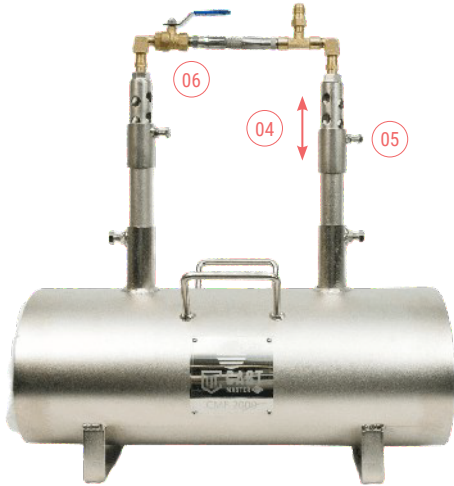

FIGURE 2

CMF 2000 – MANUAL



03

OPEN PROPANE TANK AND USE A GRILL LIGHTER TO LIGHT THE FIRST BURNER

04

ADJUST THE FLAME BY ADJUSTING THE AIR INTAKE INSIDE THE BURNER

05

USE THE SET SCREW TO LOCK THE AIR INTAKE IN POSITION

06

TO USE THE SECOND BURNER, OPEN THE VALVE ON THE BRIDGE (E) AND REPEAT STEP 4 TO 5

CMF 2000 – DISCLAIMER

- Make sure to allow a minimum of a foot and a half (18 inches) clearance between the product and any surrounding combustible items or surfaces. This space should help dissipate the heat emitted by the furnace.
- Keep the furnace away from combustible or flammable materials as the product may cause them to ignite.
- The product is best used in an area with good ventilation to avoid hazards related to fumes released by some alloys. Check local and federal guidelines for proper ventilation.
- **We recommend that you keep the original carton and packaging material to re-use in the event the furnace must be returned for servicing.**
- This is not an industrial grade smelting furnace. You may need to replace kaowool insulation over time. Slight warping and discoloration of the product's chamber will occur over time due to the high heat of the direct flame but will not affect the functionality of your furnace.



Contact Info

 castmasterelite.com

 Info@CastMasterElite.Com