



Instructions/Parts Breakdown

ESCO Jumbo Jack

10320-10326



PLEASE READ AND FOLLOW ALL WARNINGS, CAUTIONS, AND INSTRUCTIONS ASSOCIATED WITH THE PROPER USE OF THIS PRODUCT. FAILURE TO COMPLY COULD RESULT IN DEATH, BODILY INJURY, AND/OR DAMAGE TO EQUIPMENT.

ESCO EQUIPMENT SUPPLY COMPANY

CAUTION:

READ AND FOLLOW ALL WARNINGS, CAUTIONS, AND INSTRUCTIONS ASSOCIATED WITH THE PROPER USE OF THIS PRODUCT. FAILURE TO COMPLY COULD RESULT IN DEATH, BODILY INJURY AND/OR DAMAGE TO EQUIPMENT.

WARNING: This product as well as all tire tools, should never be used by persons unless they have been trained properly according to the O.S.H.A. regulation #29CFR 1910.177 entitled "Servicing Single-Piece & Multipiece Rim Wheels". Copies of this regulation can be obtained by contacting this manufacturer. 800-352-9852 or sales@esco.net

WARNING:

- This jack is for lifting only. Using it for anything beyond its intended use may cause bodily injury and/ or damage to the jack and will result in the warranty being null and void.
- Do not attempt to move or dolly the load while raised on the jack.
- The jack is not designed to sustain a load for any length of time. It is recommended that jack stands or cribbing of desired tonnages be used to sustain the load throughout the entirety of the job.
- Be sure the wheels of the vehicle to be raised are properly chocked.
- Never exceed the rated capacity of the jack. It is recommended that the load not exceed more than 90% of the jack capacity for safety reasons.
- Use the jack only on a solid surface capable of supporting the load.
- Always center the load on the lifting saddle of the jack

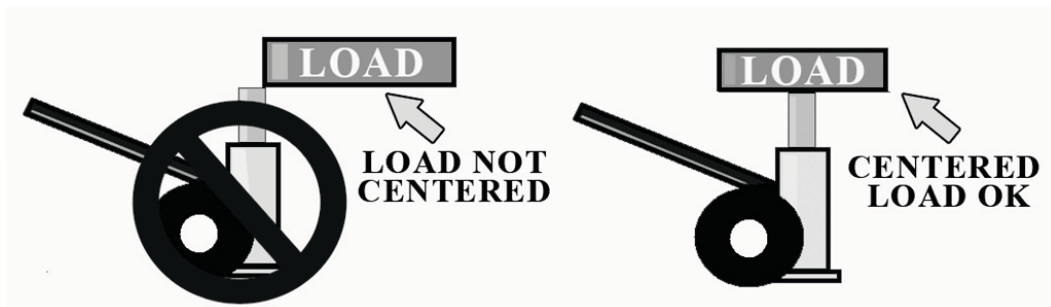

- If the jack is not perpendicular to the load slipping or loss of load is possible. Distribute load evenly when performing a lift.
- Failure to heed these warnings may cause loss of load or failure of the jack resulting in personal injury or property damage.



INSTRUCTIONS FOR USE OF THE ESCO JUMBO JACKS:

1. Using the extended handle tilt the jack back onto its transport wheels.



2. Roll the jack to the desired location under the vehicle.



3. Position the jack to align to the lifting point. Saddle extensions may be needed.



ESCO EQUIPMENT SUPPLY COMPANY

4. With the 3 position valve in the “HOLD/NEUTRAL” position connect the air line to the jack.



Move the 3 position valve to the “UP” position, and then open the air valve to activate the jack to the lifting mode. As the jack piston rod extends be sure that the lifting point on the vehicle is centered on the protective saddle or extension at the top of the jack.



5. To lower the jack move the 3 position valve to the “Down” position and activate the air valve.



ESCO EQUIPMENT SUPPLY COMPANY

NOTE: When the piston rod of the jack is extended and the u-locks are properly installed the jack can be safely used as a jack stand. THIS IS ONLY IF THE U-LOCKS ARE USED

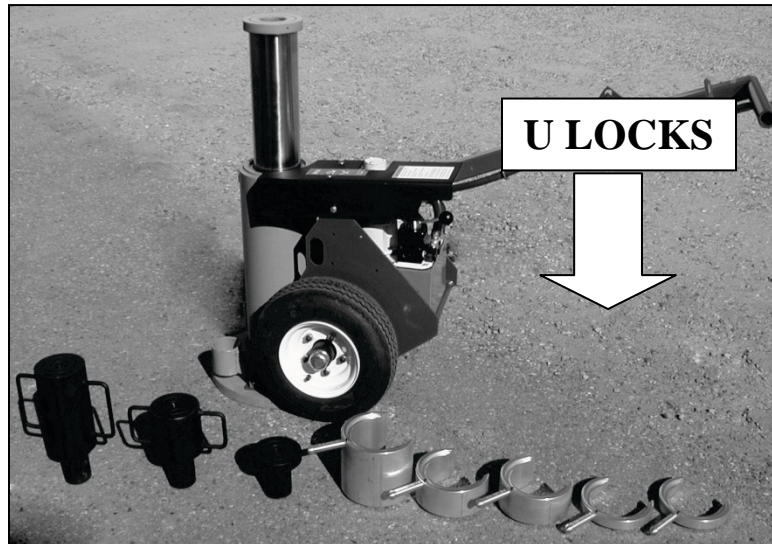

MAINTENANCE INSTRUCTIONS

- ✓ Fluid level should be 1 to 2 inches below cover plate.
- ✓ Only use recommended hydraulic fluids.
- ✓ Change out fluid periodically. Look for discoloration of fluid and check for grit in fluid.
(Any AW32 hydraulic oil will suffice).
- ✓ Change oil filter after every 50 hours of use.
- ✓ It is recommended that an in line air regulator/lubricator/water separator be used on the jack to minimize air motor contamination.
- ✓ Lubricate air motor daily.
- ✓ Lubricate all moving parts with a few drops of oil.





PARTS LIST FOR 10320-10323

PA55A
PA55A4
PA550
PA554

PA554-AA
PA90A
PA90A-JONES

MODEL C AIR HYDRAULIC PUMP

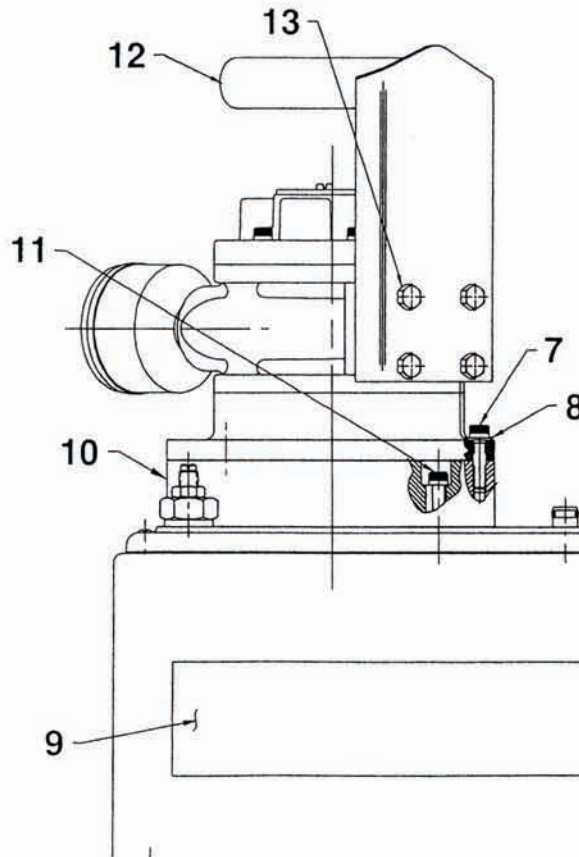
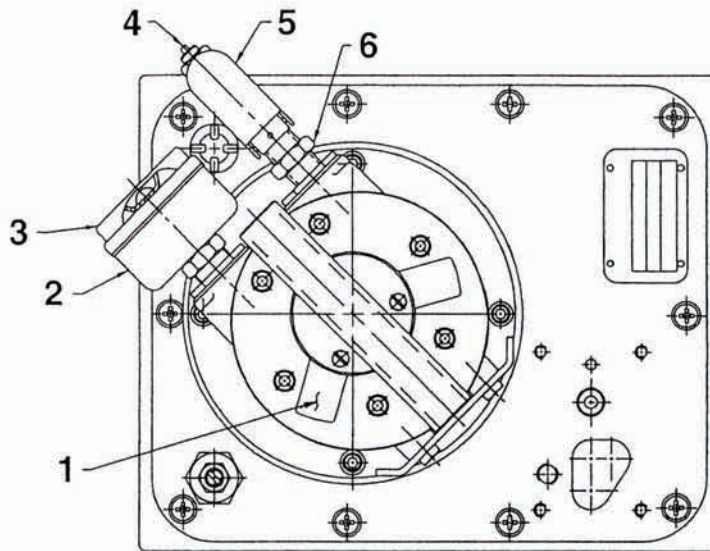

Basic Pump
Assembly
See sheet 2 of 5

Reservoir Assemblies
See sheet 5 of 5

Parts List, Form No. 108174, Back sheet 1 of 5

Item No.	Part No.	No. Req'd	Description
1	66484	1	Air Motor (See Form No. 108171)
2	13966	1	Muffler
3	205505	1	Muffler Deflector
4	11127	1	Plug Fitting (3/8 NPTF)
5	13645	1	2-way Closed Air Valve
6	14056	1	Straight Fitting (3/8 NPTF)
7	10016	4	Soc. Hd. Screw (1/4-20 x 1)
8	10244	4	Lockwasher (.49 x .26)
9	309219	2	Trade Name Decal (Power Team)
10	422056	1	Motor Base
11	10022	4	Soc. Hd. Screw (1/4-20 x 1-1/2)
12	422102BK2	1	Handle Weldment
13	10005	4	Hex Hd. Cap Screw (1/4-20 x 1/2)

} For PA550, PA554, PA554-AA, & PA90A-JONES

VALVE OPTIONS

9500	1	4-way Tandem Center Manual Valve (For PA554: See Form No. 100623)
66208	1	4-way Pump Mount Air Valve (For PA554A4 & PA554-AA; See Form No. 108068)

PARTS INCLUDED BUT NOT SHOWN

16797	1	90° Elbow Fitting	} For PA554-AA
9689	1	Reducer Connector	
14680	2	90° Elbow Fitting	} For PA55A4
208218	6	Straight Fitting	
421265	1	Air Operated Hand Control	
251759	1	Pump Instruction Decal	
251760	1	Release Instruction Decal	
45052	1	Three Strand 12' hose	
200609	1	Drain Tube (For PA554-AA & PA55A4)	

GENERAL PUMP ASSEMBLY

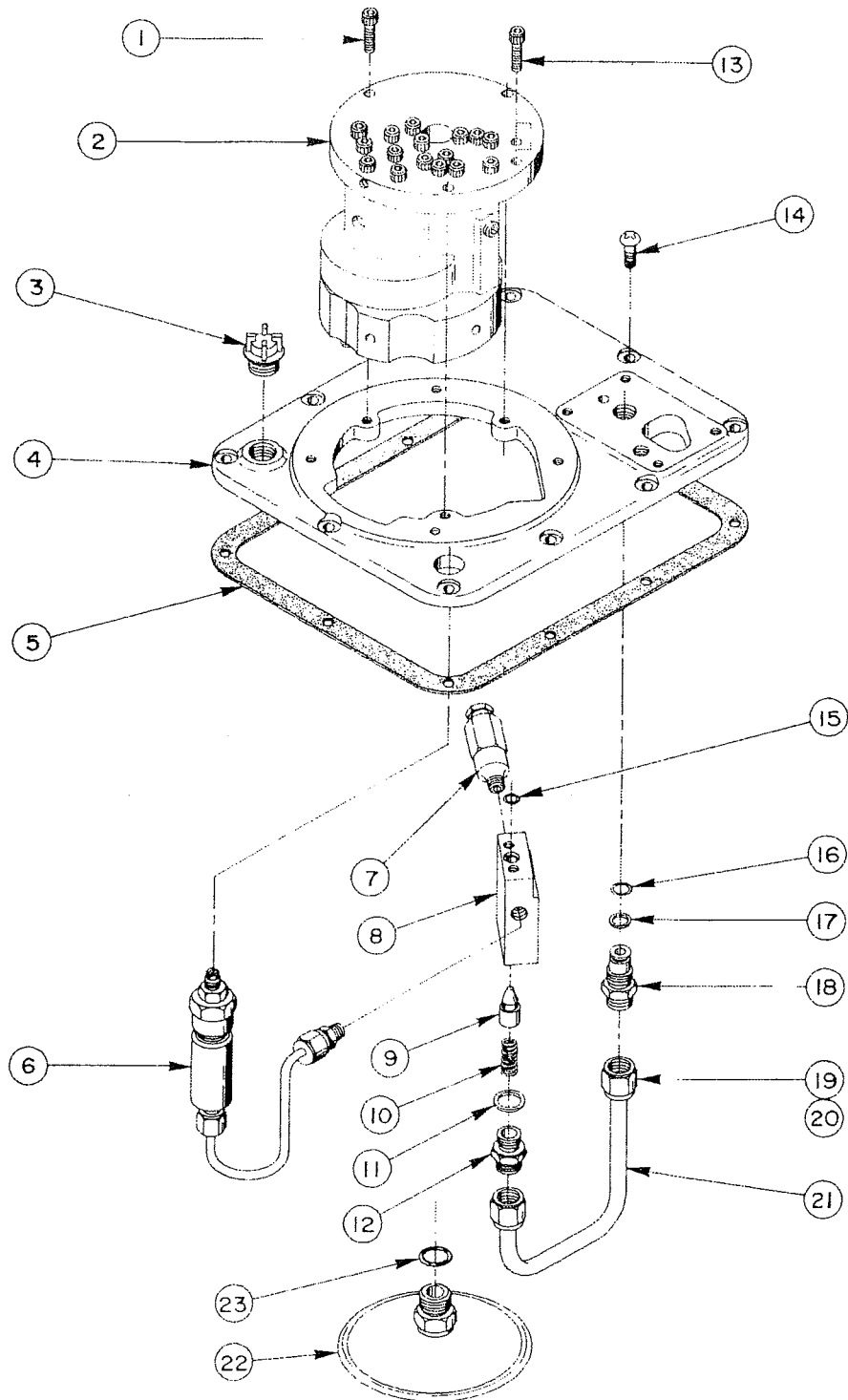

Parts List, Form No. 108174, Back sheet 2 of 5

Item No.	Part No.	No. Req'd	Description	Item No.	Part No.	No. Req'd	Description
1	10016	3	Soc. Hd. Cap Screw (1/4-20 UNC X 1" Lg.)	11	10261	1	(3/8 O.D. X 3/4 Lg.) Copper Washer (3/4 X 19/32 X 1/32)
2	*27206	1	Basic Pump Ass'y Replacement (See chart below)	12	20770	1	Connector (Torque to 40/45 ft. lbs.)
	*28349	1	Basic Pump Ass'y Replacement (See chart below)	13	10015	2	Soc. Hd. Cap Screw (1/4-28 UNF X 1" Lg.; Torque to 180 in. lbs.)
3	20937	1	Filler Plug	14	10177	10	Mach. Screw (1/4-20 UNC X 3/4 Lg.)
4	40064WH2	1	Cover	15	10266	1	O-ring (3/8 X 1/4 X 1/16)
5	40164	1	Gasket	16	10268	1	O-ring (1/2 X 3/8 X 1/16)
6	22360	1	Pressure Regulator Ass'y (See below)	17	11863	1	Teflon Backup Washer (1/2 X 3/8 X 1/16)
7	21278	1	Relief Valve (Set at 10,100/10,700 PSI)	18	20787	1	Valve Connector
	21278-50	1	Relief Valve (Set at 5,100/5,700 PSI)	19	10430	2	Tube Sleeve
	21278-15	1	Relief Valve (Set at 1,500/1,700 PSI)	20	10431	2	Tube Nut
8	20776	1	Valve Body	21	21045	1	Oil Line
9	20771	1	Poppet	22	21345	1	Filter Ass'y (Includes Item 23)
10	10425	1	Compression Spring	23	10527	1	O-ring (13/16 X .644 X .087)

*Includes all items on sheet 3 of 5 and items 1, 7, 8, 9, 10, 11, 12, 13, 15 & 22 on this sheet.

BASIC PUMP REPLACEMENT CHART Low Speed (3,450 RPM)

SERIES	MAX. PSI	BASIC PUMP & COVER PLATE ASS'Y	BASIC PUMP REPLACEMENT	HIGH PRESSURE PUMP ASS'Y USED	NO. OF PISTONS
PA55A, PA554-AA, PA550, PA554, PA55A4	10,000	50404	27206*	33113	3
PA90A	5,000	50406	28349*	33114	6
PA90A-JONES	1,500	50406-15	-	33114	6

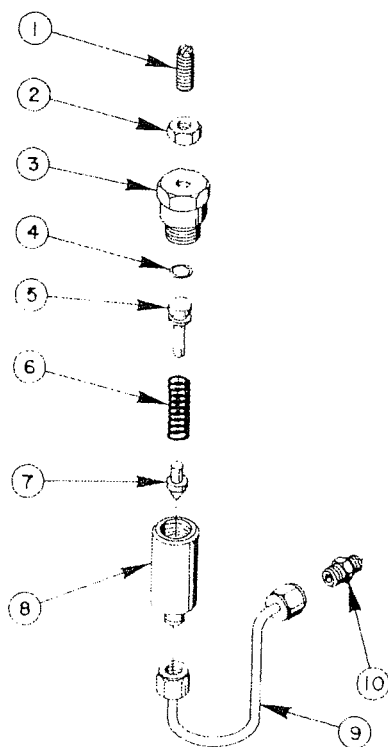

PRESSURE REGULATOR ASSEMBLY

Item No.	Part No.	No. Req'd	Description
1	22362	1	Adjusting Screw
2	10386	1	Hex Jam Nut (3/8-24 UNF)
3	21305	1	Valve Cap
4	10268	1	O-ring (1/2 X 3/8 X 1/16)
5	21306	1	Spring Guide
6	10495	1	Compression Spring
7	21046	1	Valve Stem
8	22361	1	Body
9	29267	1	Oil Line Ass'y (With nuts)
10	14844	1	Connector Fitting

BASIC PUMP ASSEMBLY

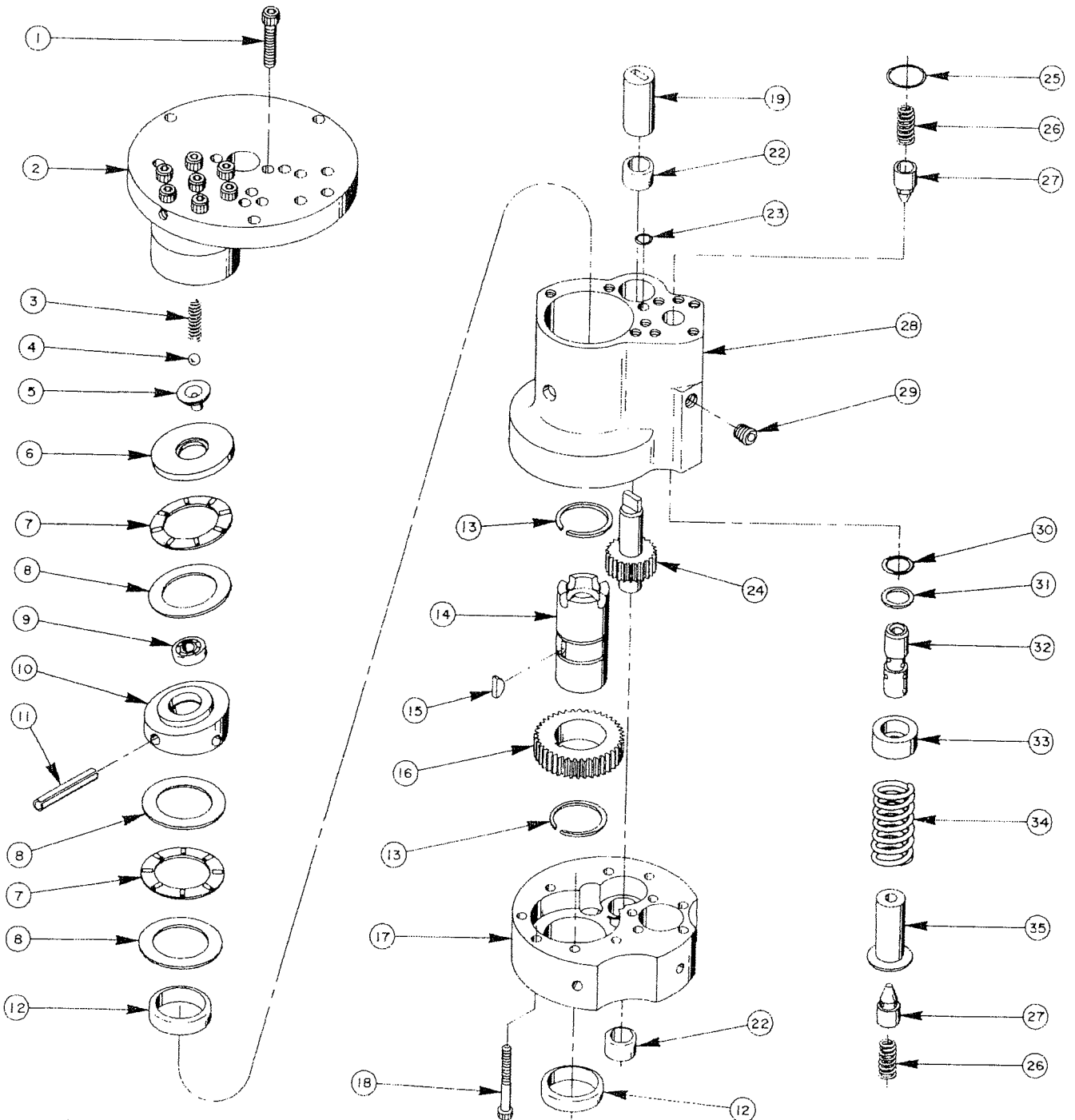

Parts List, Form No. 108174, Back sheet 3 of 5

Item No.	Part No.	No. Req'd	Description
1	10020	9	Soc. Hd. Cap Screw (1/4-20 UNC X 1-1/4" Lg.; Torque to 170-180 in. lbs.)
2	33113	1	High Pressure Pump Ass'y (See sheet 4 of 5 & chart on back of sheet 2 of 5)
	33114	1	High Pressure Pump Ass'y (See sheet 4 of 5 & chart on back of sheet 2 of 5)
3	10361	1	Compression Spring (1/4 O.D. X 1" Lg.)
4	10375	1	Steel Ball (1/4" Dia.)
5	23547	1	Bearing Top Plate
6	23548	1	Top Plate
7	11228	2	Thrust Bearing
8	11813	3	Bearing Race
9	11814	1	Ball Bearing
10	23549	1	Angle Plate
11	11955	1	Roll Pin
12	11064	2	Needle Bearing
13	11261	2	Retaining Ring
14	23556	1	Shaft
15	11821	1	Woodruff Key
16	23557	1	Gear
17	30533	1	Pump End Plate
18	10001	12	Soc. Hd. Cap Screw (#10-32 UNF X 1-3/4 Lg.; Torque to 50 in. lbs.)
19	252108	1	Coupling
22	11199	2	Needle Thrust Bearing (See note below)
23	10266	1	O-ring (3/8 X 1/4 X 1/16)
24	21272	1	Drive Gear
25	10303	1	O-ring (7/8 X 3/4 X 1/16)
26	10425	2	Compression Spring (3/8 O.D. X 3/4 Lg.)
27	20771	2	Poppet
28	40120	1	Pump Body
29	10427	1	Pipe Plug (1/8" NPTF)
30	10271	1	O-ring (11/16 X 1/2 X 3/32)
31	12389	1	Teflon Backup Washer (11/16 X 1/2 X 1/16)
32	20849	1	Spool
33	23255	1	Spring Guide
34	10426	1	Compression Spring (1" O.D. X 1-13/16 Lg.)
35	23256	1	Spring Guide

NEEDLE BEARING INSTALLATION SPECIFICATIONS

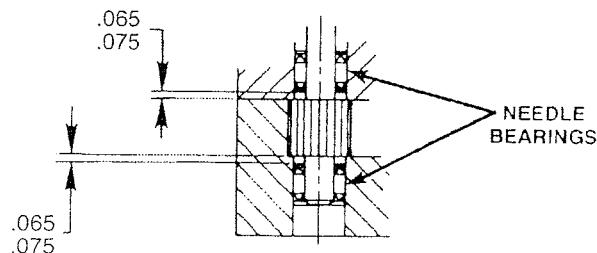

When replacing the needle bearings on the drive gear of the basic pump, the dimensions shown must be as specified.

Note: Shaded areas reflect last revision(s) made to this form.

HIGH PRESSURE PUMP ASSEMBLY

SEE DIAGRAM
ON REVERSE SIDE
FOR IMPORTANT
ASS'Y.
INFORMATION

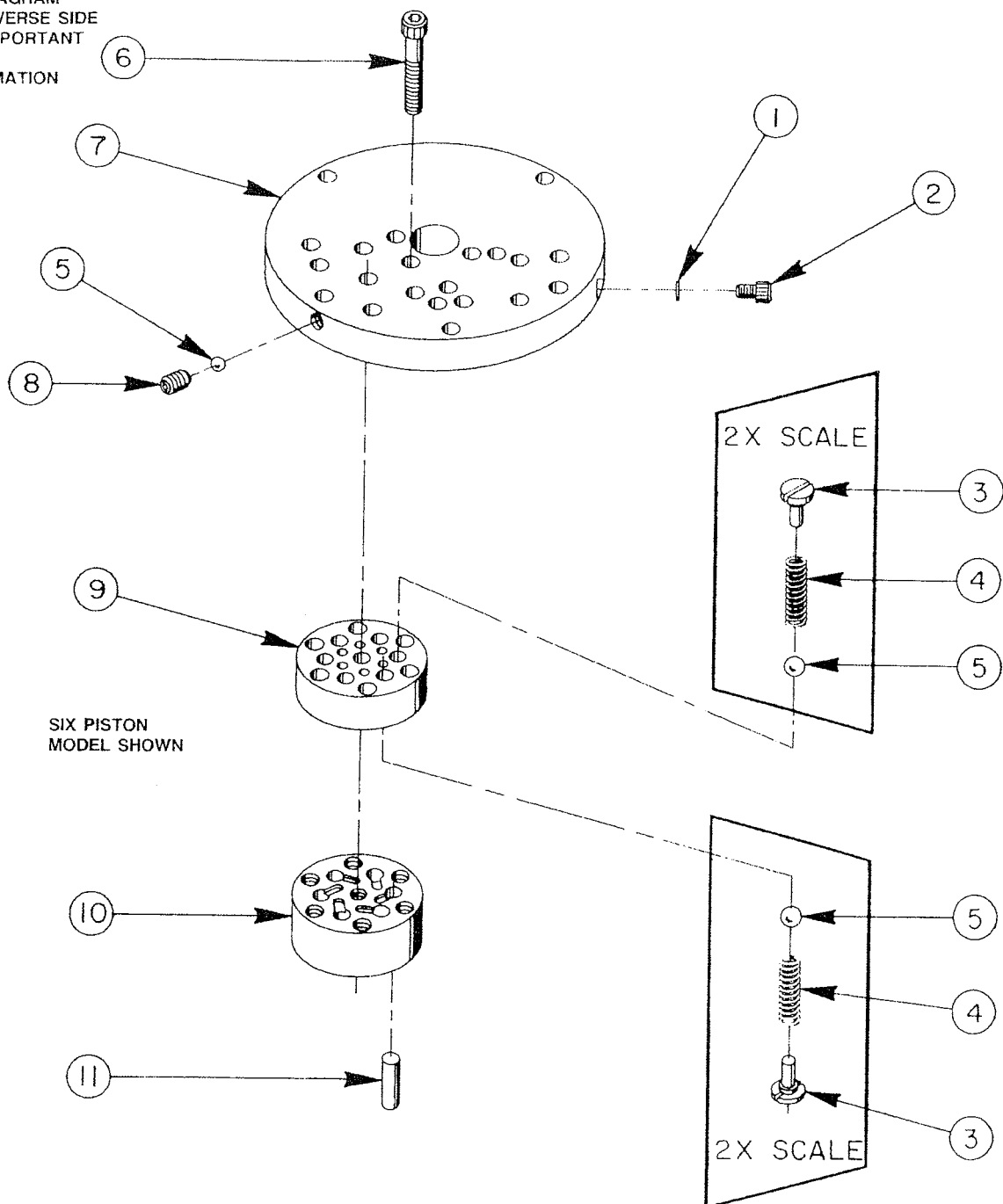

SIX PISTON
MODEL SHOWN

33113 PUMP ASSEMBLY
3 Pistons - 9/32 Dia.

Item No.	Part No.	No. Req'd	Description
1	10442	1	Copper Washer (3/8 X 1/4 X 1/32)
2	10002	1	Soc. Hd. Cap Screw (1/4-20 UNC X 3/8" Lg.; Torque to 140/160 in. lbs.)
3	24549	6	Valve Guide
4	10445	6	Compression Spring (5/32" O.D. X 3/4" Lg.)
5	12223	7	Steel Ball (3/16" Dia.)
6	10023	7	Soc. Hd. Cap Screw (1/4-28 UNF X 1-1/2 Lg.; Torque to 170/180 in. lbs.; See note below)
7	50411	1	Top Plate
8	10519	1	Soc. Set Screw (1/4-20 UNC X 3/8 Lg.; Torque to 65/70 in. lbs.)
9	40630	1	Valve Head
10	41062	1	Pump Barrel
11	21628	3	Piston

33114 PUMP ASSEMBLY
6 Pistons - 9/32 Dia.

Item No.	Part No.	No. Req'd	Description
1	10442	1	Copper Washer (3/8 X 1/4 X 1/32)
2	10002	1	Soc. Hd. Cap Screw (1/4-20 UNC X 3/8" Lg.; Torque to 140/160 in. lbs.)
3	24549	12	Valve Guide
4	10445	12	Compression Spring (5/32" O.D. X 3/4" Lg.)
5	12223	13	Steel Ball (3/16" Dia.)
6	10023	7	Soc. Hd. Cap Screw (1/4-28 UNF X 1-1/2 Lg.; Torque to 170/180 in. lbs.; See note below)
7	50411	1	Top Plate
8	10519	1	Soc. Set Screw (1/4-20 UNC X 3/8 Lg.; Torque to 65/70 in. lbs.)
9	41048	1	Valve Head
10	41063	1	Pump Barrel
11	21628	6	Piston

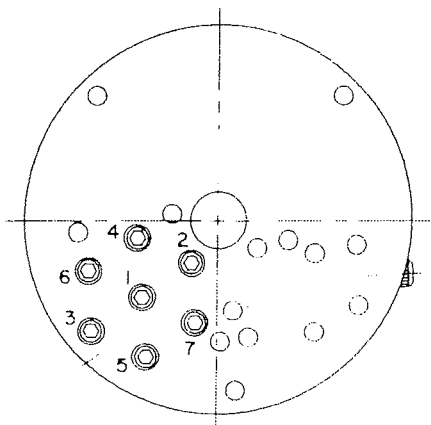

BOLT TIGHTENING SEQUENCE

NOTE: Assemble in sequence shown.
 Lubricate under head and on threads.
 Torque to 180 in. lbs.

RESERVOIR ASSEMBLIES

2 GAL. RESERVOIR

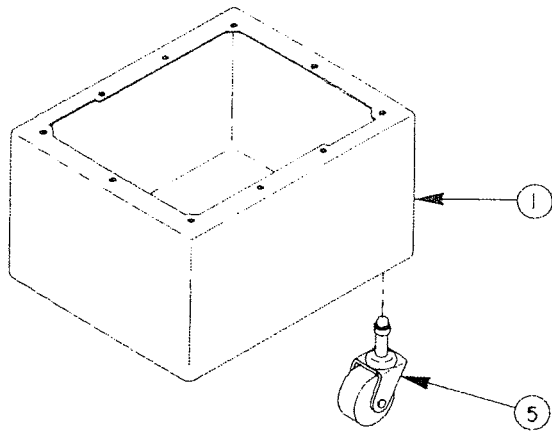

5 & 10 GAL. RESERVOIRS

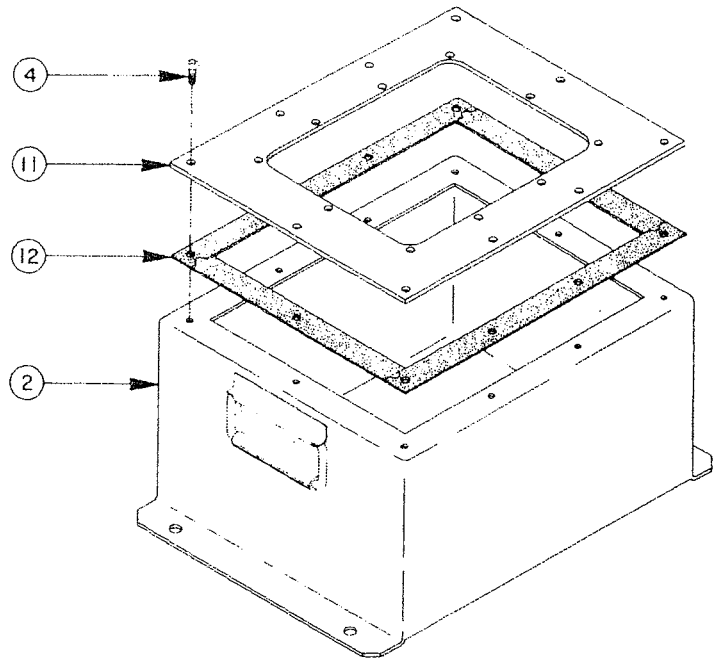

FILTER & EXTENSIONS

Used on 5, 7 & 10 Gal. Reservoirs as Applicable

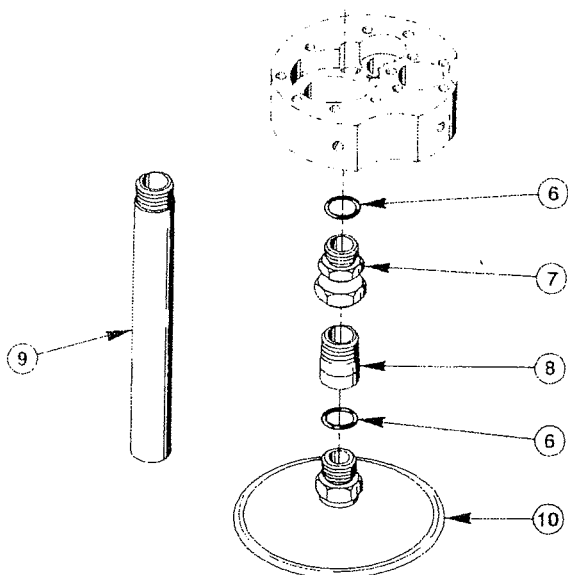

7 GAL. RESERVOIR

