



READ INSTRUCTIONS THOROUGHLY BEFORE OPERATING



TIRE SERVICE INTERNATIONAL

800.223.4540

3451 S. 40th St.
Phoenix, Az 85040
602-437-5020













www.buytsi.com
sales@buytsi.com
Fax. 602-437-5025



WARNING!

The instructions and warning contained in this manual should be read and understood before using or operating this tool. Do not allow anyone

to use or operate this tool until they have read this manual and have developed a thorough understanding of how this tool works. Failure to observe any of the following instructions could result in severe personal injury to tool user and bystanders, or cause damage to the tool and property. Keep this manual for future reference.

-  **WARNING** - Indicates a potentially hazardous situation which, if not avoided, could result in death or serious injury.
-  **WARNING** - Personal Protective Equipment: Safety goggles, gloves, non-skid shoes and hearing protection.
-  **WARNING** - Keep bystanders and children out of the work area while operating this tool.
-  **WARNING** - Always keep work clean, uncluttered, and well lit. Do Not work on floor surfaces that are slippery.
-  **WARNING** - Do not operate this tool if you are tired or under the influence of alcohol, drugs, or medications that could affect your ability to use the tool properly.
-  **WARNING** - Air under pressure can cause severe injury. Never point an air tool at people or animals.
-  **WARNING** - Detach from air supply and release all air pressure before installing, removing or adjusting any accessory on this tool or performing maintenance. Failure to do so could result in injury.
-  **WARNING** - Do not open the Cheetah® Bead Seater air release valve when connecting the air supply hose. When the Cheetah® Bead Seater is not in use, discharge air from tank. Store with valve open in a clean, dry location. Never transport the Cheetah® Bead Seater with air in the tank.
-  **WARNING** - Do not tamper with the safety valve. Do not modify or alter the bead seater in any way.
-  **WARNING** - Inspect before each use. Do not use if broken, bent, cracked or damaged parts are noted (Including warning label). If the unit appears damaged in any way, is missing parts, or operates abnormally, it shall be removed from service immediately. All units that have been dropped, impacted suddenly, or dented should be removed from service.
-  **WARNING** - Only Cheetah® Bead Seating replacement parts should be used on the unit. Decals and parts are available through your Distributor or the manufacturer.
-  **WARNING** - The warnings, cautions and instructions discussed in this manual cannot cover all possible conditions and situations that may occur. It must be understood that common sense and caution are factors which cannot be built into this product, but must be applied by the operator.
-  **WARNING** - Operator should be familiar with all OSHA regulations (including 29 CFR 1910.177) pertaining to mounting, demounting and inflating all tires

Label Description



Pressurized Device



Eye and Ear Protection



Read the Manual

BS-07 BEAD SEATING TOOL

OPERATING INSTRUCTIONS

Please read all information before operating the bead seater.

Safety is of prime importance

DO'S

1. Operator must wear eye protection.
2. Keep bystanders 20 feet away when tank is charged.
3. Always store and transport with discharge valve open.
4. Be sure pressure release is clear of foreign matter (i.e. ice or dirt).
5. Keep away from children

DON'TS

1. Do not tamper with pressure safety release. Excessive pressure could cause tank failure resulting in injury.
2. Do not store or transport in charged condition to prevent injury from inadvertent opening of discharge valve.

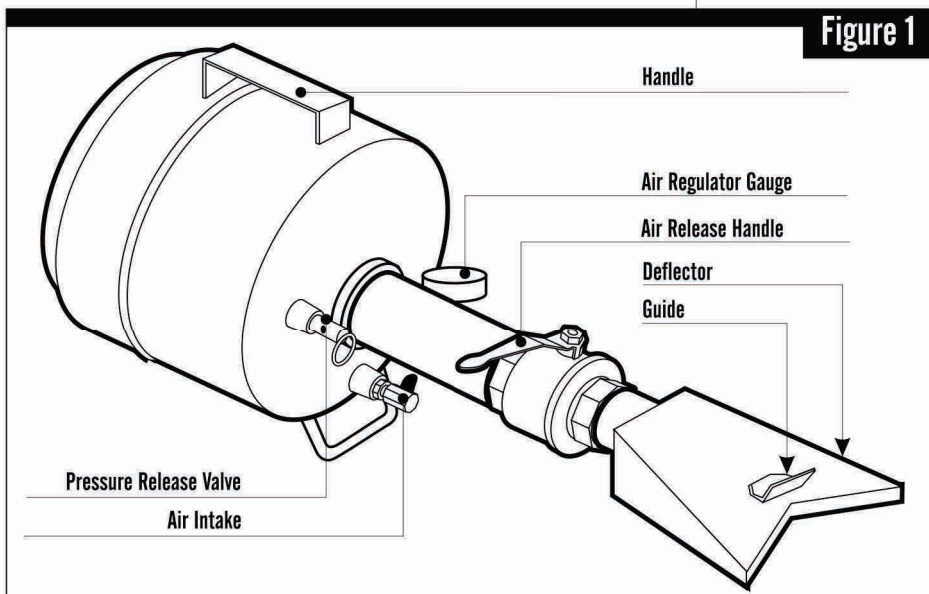

Figure 1

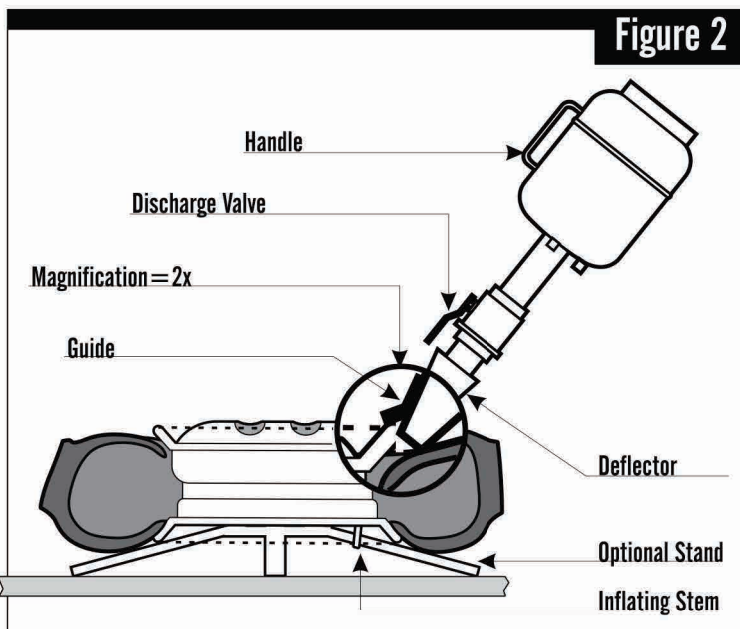

Figure 2

OPERATING INSTRUCTIONS

1. Be sure to use eye protection (STOP HERE AND OBTAIN EYE PROTECTION NOW !!!!).
2. Keep a clear working area.
3. (Refer to Figure 2) Lay mounted tire flat on floor or ground with narrow bead up (inflating stem facing down) place stand under rim near inflating stem (Stand Optional).
4. Fill bead seater tank to 60 PSI from compressed air supply (practice a few times at this pressure). Increase pressure as necessary. Safety pop off set at 120 PSI.
5. Attach self holding chuck from air supply to inflating stem on rim.
6. Hold bead seater at an approximately 45 degree angle from floor with guide on top of rim.
7. Hold handle tight and quickly open discharge valve.

Extremely difficult tires may require a higher pressure.

For tires larger than truck tires a greater volume of air is needed larger units are available.

SAFETY:

Use common sense and instruct other users to be safety conscious. Wear eye protection.



TIRE SERVICE INTERNATIONAL

800-223-4540 www.buytsi.com

3451 South 40th Street · Phoenix, Arizona 85040 · Arizona 602.437.5020 · fax 602.437.5025

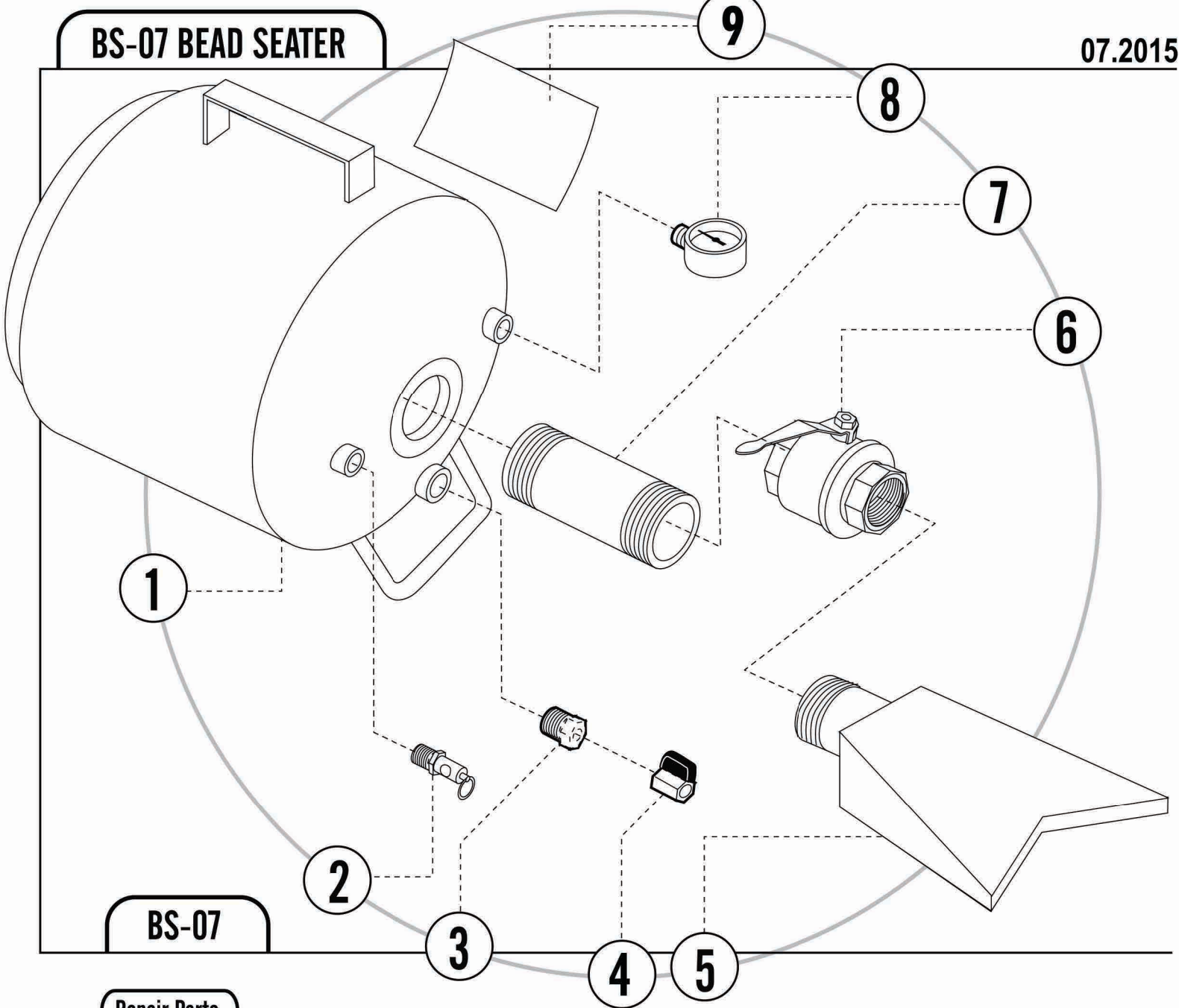

BS-07

Repair Parts

No.	Description	Part No.	No.	Description	Part No.
1.	Air Tank	N/A	6.*	Discharge Valve	03.102
2.	Safety Release Valve	05.102	7.	6" Pipe Nipple	02.104BS
3.	3/4" - 1/4" Bushing	01.107	8.	Pressure Gauge	01.106
4.	Ball Valve	04.103	9.	Decal	01.114
5.	Flared Barrel	6813			

*Includes Handle

Order parts from your distributor or jobber. When ordering parts always give the following information: *Part Number, Description and Serial Number of Your Machine.*

REMINDER: Always exercise caution when using compressed air.



TIRE SERVICE INTERNATIONAL

Warranty Statement & Return Policy

Warranty & Workmanship you can depend on.

With over 25 years of manufacturing experience we maintain the ability to provide competitive prices while employing and manufacturing the majority of our products in the USA. Pride in our workmanship and standing behind each and every product is not just our claim but our uncompromising responsibility.

TSISSG equipment is warranted to be free from defects in materials and workmanship for a period of one year from the date of original purchase to the original owner. Repair labor is warranted for 90 days from the date of original purchase. Bushings, blades, bearings and normal wear and tear are not covered under warranty. Careless handling, negligence, misuse, abuse, mutilation, improper operation, making unauthorized repairs, additions, and or alterations automatically cancel this warranty and relieves TSISSG of any obligation. Cheetah tanks claimed to be defective while under warranty will be evaluated at our manufacturing plant and either repaired if possible or exchanged and returned or credit issued to the customer account at our discretion. Damage resulting from dropping the tanks will not receive warranty consideration. Warranty parts need to be returned prepaid to the plant for credit. Any replacement parts shipped from the plant will be shipped at the customer's expense. Machines requiring warranty work must be brought to the manufacturing plant in 201 Chelsea Rd, Monticello, MN or to a repair facility authorized by TSISSG.

Return Policy:

!!WARNING!! Goods returned without an RGA will be refused. A Returned Goods Authorization form must be obtained before returning any material or goods. All non-warranty returns will be subject to a 15% restocking fee plus any additional charges for reconditioning/repacking.

