

LEDVANCE® DAMP PROOF LED EMERGENCY DRIVER G2

43W / 61W

4 000K / 6 500K



Beneficios

- ✓ Difusor en PC: alta resistencia
- ✓ Fácil instalación
- ✓ No requiere el uso de lámparas complementarias
- ✓ Certificación NOM
- ✓ Carga de batería en 24 hrs
- ✓ Hasta 3 horas de iluminación de emergencia

IP65

VIDA ÚTIL
30 000 hrs



Aplicaciones

VALUE
CLASS



Estacionamientos



Vapores y
Saunas



Cámaras
Frigoríficas



Hangares



Almacenes /
Industrias

Características del Producto

Potencia Nominal	43W	60W	61W
Flujo Luminoso	4 773 lm	6 969 lm	6 954 lm
Equivalencia	2x32W T8	2x59W T8	
Tensión Nominal	100-277 V~		
Frecuencia	50/60 Hz		
Eficiencia	111 lm/W	116 lm/W	114 lm/W
Temperatura de Color	4 000 K / 6 500 K		
Índice de Reproducción de Color (IRC)	>80		
Factor de Potencia	>0.9		
Ángulo de Apertura	115°		
Vida Útil	30 000 h (L70)		
Atenuable	No		
Índice de Protección	IP65		
Protección contra Impactos Mecánicos	IK08		
Mínima y Máxima Temperatura de Operación	-20~... +40°C		
Mínima y Máxima Temperatura de Almacenaje	-40~... +70°C		
Distorsión de Armónicas (THD)	<20%		
Garantía de la Luminaria	3 años		
Garantía de Driver de Emergencia	2 años		
Garantía de Batería	1 año		
Carga Completa	24 hrs		
Tiempo de Encendido en Modo Emergencia	3 hrs		
Flujo Luminoso en Modo Emergencia	600 lm		
Material de la luminaria	Policarbonato		

Datos del Producto

Clave	Descripción	Pieza Caja	Peso (g)	EAN 10	Dimensiones EAN10 (mm)	Peso EAN 10 (g)	EAN 40	Dimensiones EAN40 (mm)	Peso EAN 40 (g)
88569	LEDVANCE DAMP-PROOF LED EMERG 43W/840	6	1630	405807555 8540	1205x82x71	1768	405807555 8557	1225x185x247	11079
88570	LEDVANCE DAMP-PROOF LED EMERG 43W/865	6	1630	405807555 8588	1205x82x71	1768	405807555 8595	1225x185x247	11079
80356	LEDVANCE DAMP-PROOF LED EMERG 60W/840	6	1850	405807540 1396	1505x82x73	1850	405807540 1402	1510x170x150	11100
88572	LEDVANCE DAMP-PROOF LED EMERG 61W/865	6	1950	405807555 8649	1505x82x71	2118	405807555 8656	1525x185x247	12897

Dimensiones Del Producto

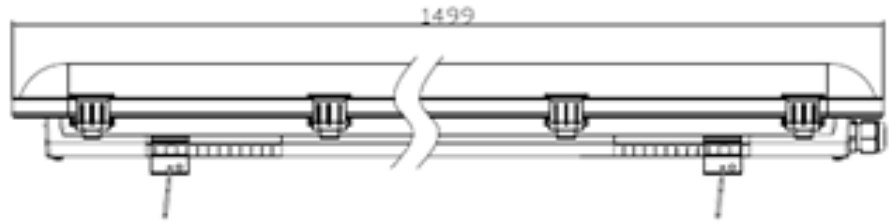

43W

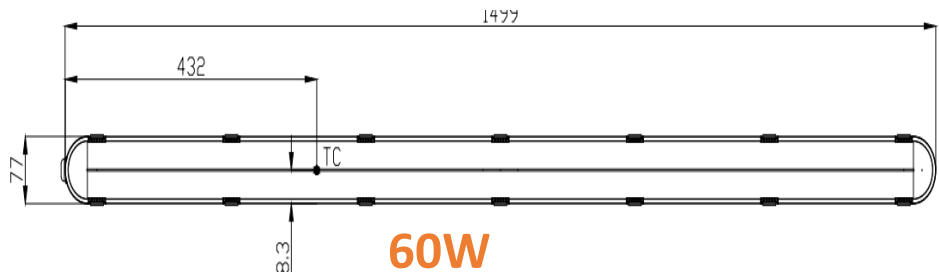

60W

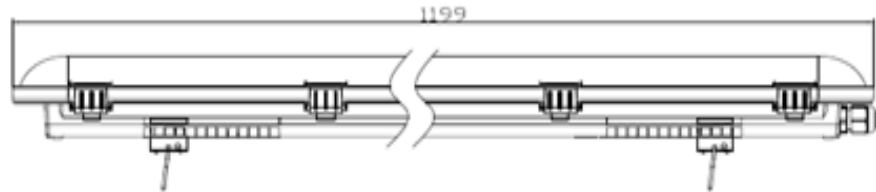
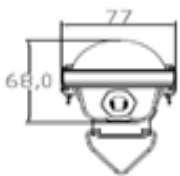

61W

Diagrama De Conexiones



Diagrama Fotométrico

Curva Iluminación-Distancia



43W

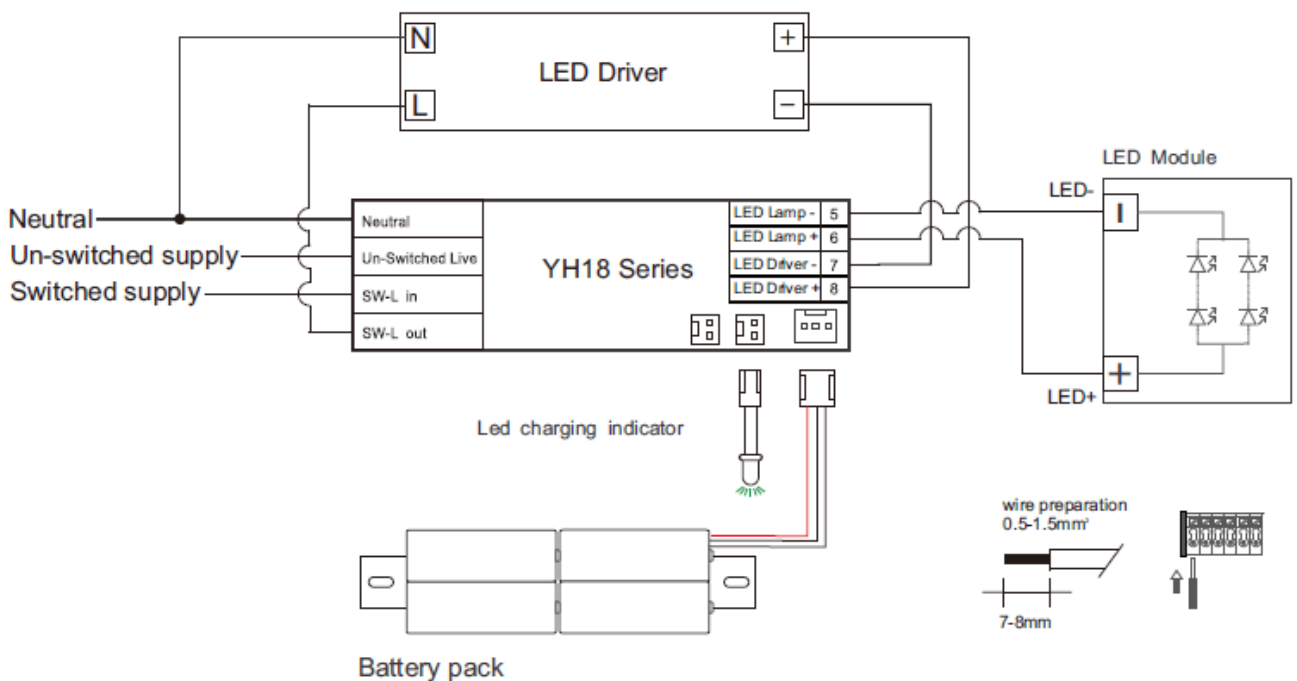
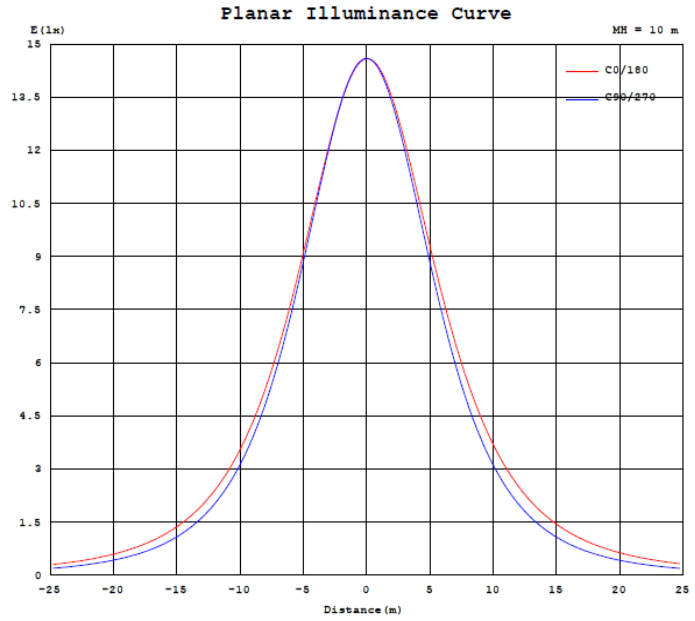
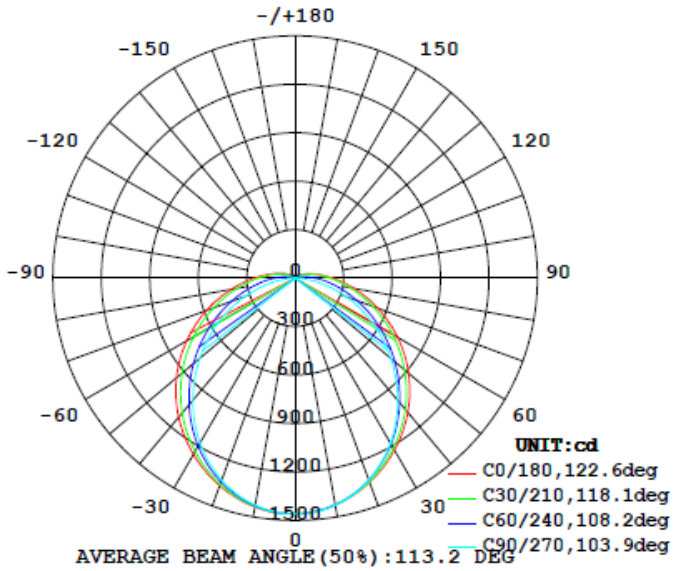
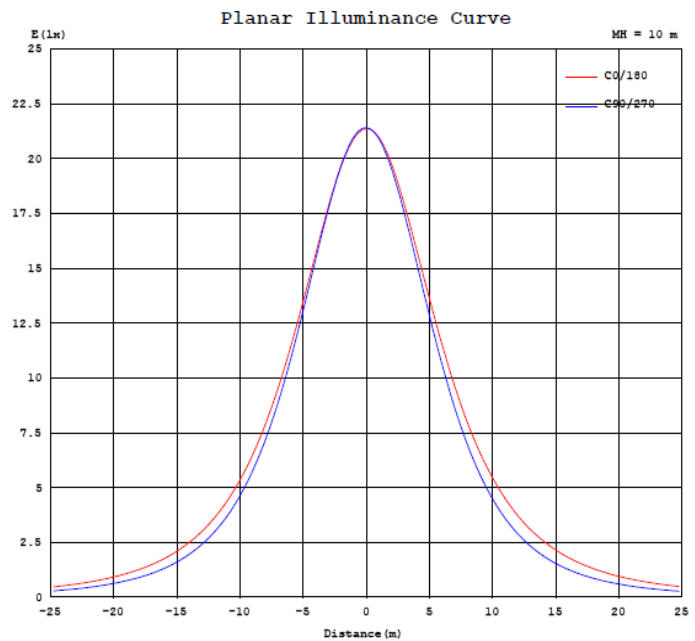
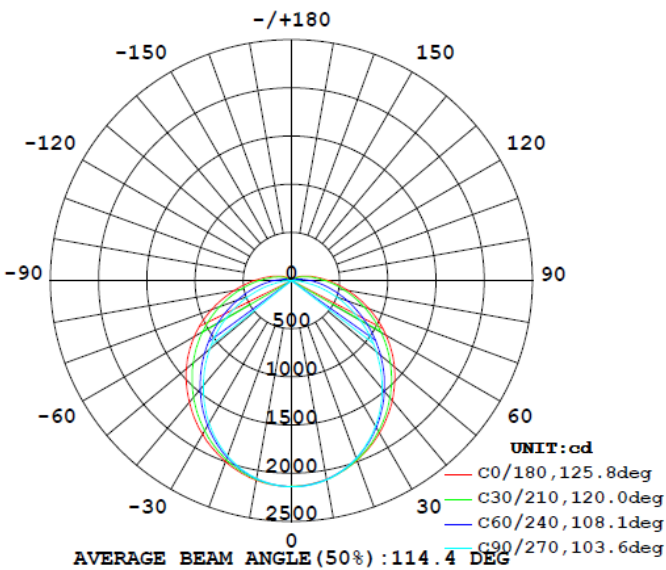

61W