

Korniche®

A LANTERN REVOLUTION

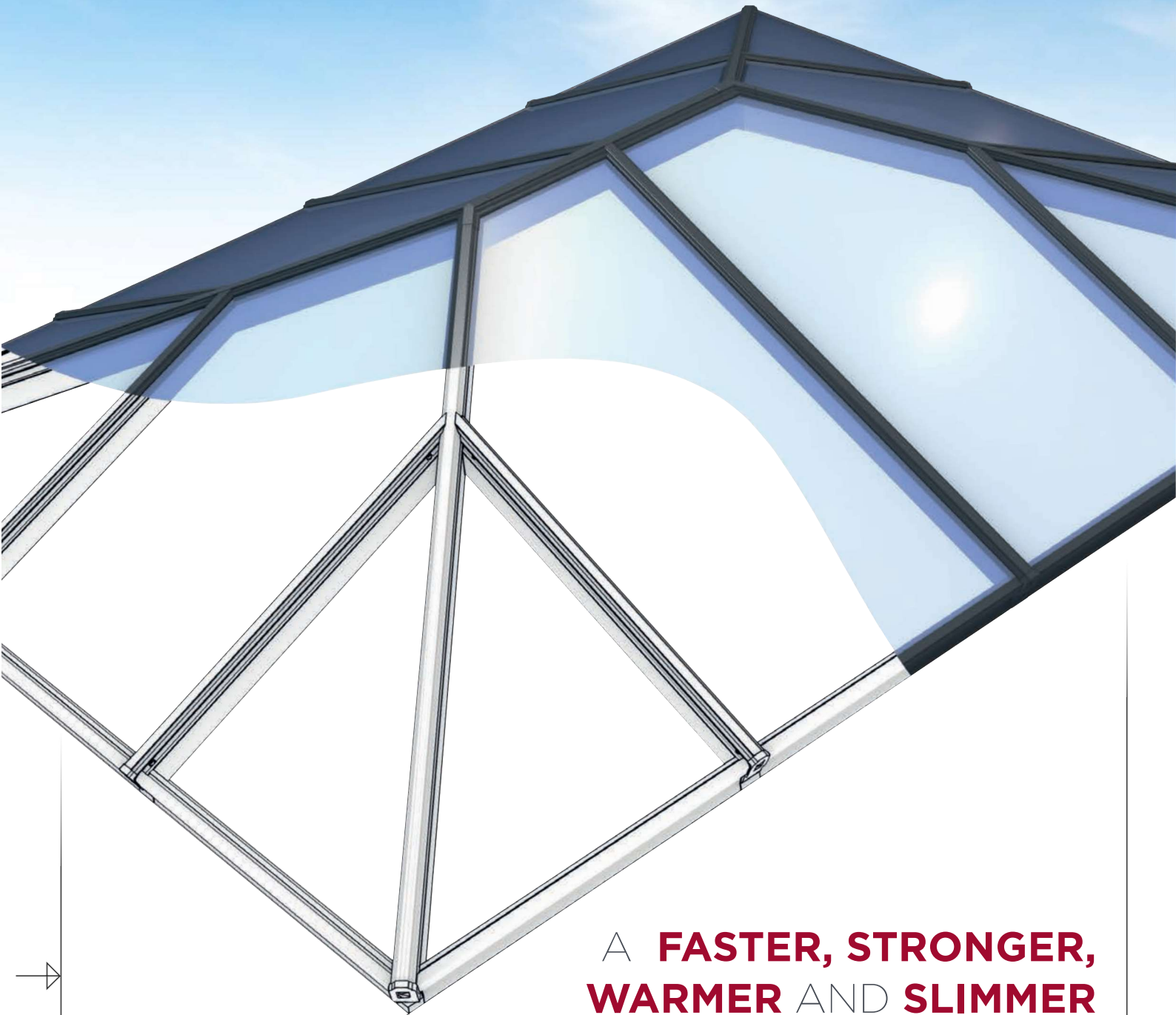

A **FASTER, STRONGER,
WARMER AND SLIMMER**
ALUMINIUM ROOF LANTERN
HAS ARRIVED

VERSION
Next Generation

MATERIAL
Thermally Efficient

DETAIL 1
Fixed 25° Pitch

DETAIL 2
Slimline



A revolutionary thermally broken aluminium roof lantern has arrived. The brief: To design a new roof system that is...



FASTER

QUICKER AND EASIER TO INSTALL

STRONGER

OPTIMISED TO ALLOW MINIMAL STRUCTURE

WARMER

CLASS LEADING THERMAL PERFORMANCE

SLIMMER

AESTHETICALLY STUNNING

Made For Trade's in house development team have successfully blended contemporary, yet classic design with cutting edge engineering concepts to create an astonishingly beautiful roof lantern, strongest and most thermally efficient in its class it is also incredibly quick and simple to install.

Korniche: the perfect evolution of form and function.

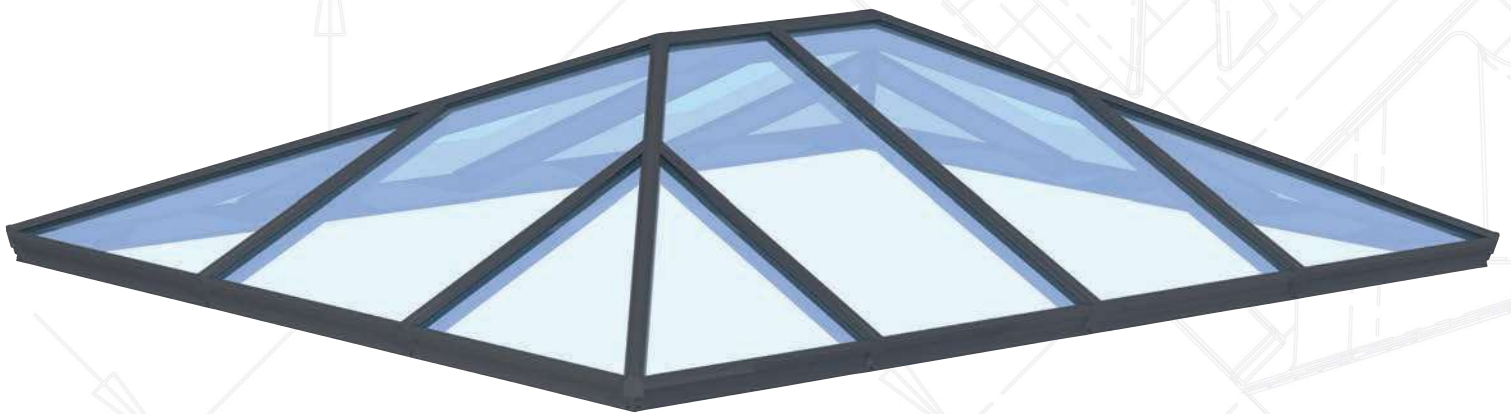

“Having previously worked with aluminium and upvc roof lanterns we decided to use the Korniche. Allowing the usual time for fitting we were pleased to find the ease of construction resulted in an earlier completion time and a great all round result from this well engineered product **”**

Turners of Horncastle Ltd

NO SEALANT IN ROOF CONSTRUCTION

Once the eaves beam has been fitted and secured into its position on the existing roof, the installer need not concern themselves further with any application of sealant during construction of the Korniche. All further seals are pre-fitted as required, no fuss, no mess, no additional materials required and most importantly no wasted time.

UNIVERSAL 5MM ALLEN KEY

A 5mm Allen key bit is included with every Korniche roof and provides the interface needed between your tools and the fasteners that make up our system.



TAPERED WASHER

To allow for a quick and precise fixing between all the spars, bosses and eaves beams we have engineered a simple yet innovative tapered washer. The conical profile results in a wedge type insert which allows a large degree of positional tolerance on the mating holes of the cast lugs and spars. This system vastly simplifies the preliminary fit up helping to increase the overall ease and speed of installation.

Once everything is correctly in place, the connecting bolts are fully tightened and these tapered washers ensure that each joint is both fully aligned and correctly pre-loaded in a single process, providing an incredibly accurate and stable assembly.



1. PRE-DRILLED EAVES BEAM

To save fitting time and guarantee that the correct amount of fixings are used, we ensure that every single roof leaves our factory with all the required holes pre-drilled into its eaves beam. For the installer, this means there is no additional measuring or drilling necessary on site prior to fastening the eaves beam onto the roof upstand.



FASTER



STEP BY STEP INSTALLATION MANUAL

Korniche comes delivered as a kit with all parts securely wrapped and boxed to ensure safe transit. Each kit contains a step by step pictorial guide which walks the installer clearly through the build process from start to finish.

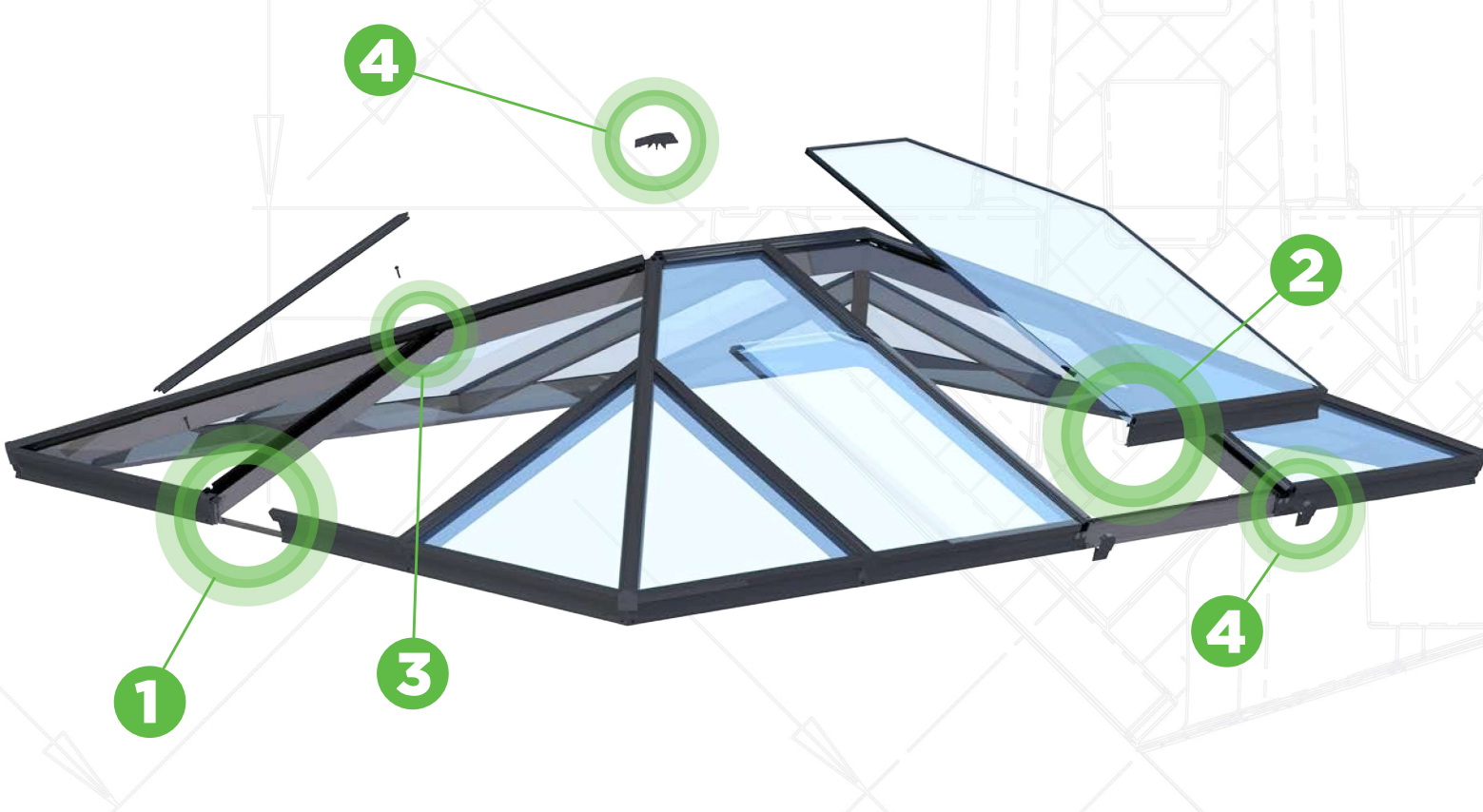

mft 4 x FASTER TO FIT

“Great product. Quick and easy to install, looks amazing”

Alpine. Bridlington

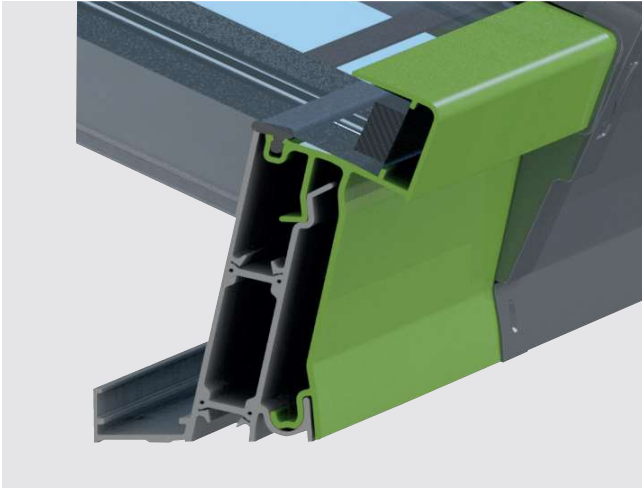

2. ALL IN ONE GLAZING RETAINER

Installing the glass couldn't be simpler using our all in one glazing retainer. The innovative design prevents slip and covers both the end of the sealed unit and the external portion of the eaves beam in one. Once located into the retainer, the glazing panel is simply positioned on the ridge and rotated down as the assembly guides it into position, reducing the install time to a matter of seconds per unit.

The clever design creates an anti-lift mechanism to both stop ambient air escaping and adds another dimension to security against forced entry from the outside.



3. ONE BOLT SPAS

Rafter fitment is completed by orientating the end of the spa over its relevant die cast lug and fixing in place using a single 8mm bolt. At the eaves beam end, one more 8mm bolt is fitted from the outside, through the profile and then into a pre-fitted aluminium lug sitting neatly inside the end of the rafter. The utilisation of our tapered washer system ensures that when the bolts are torqued, correct alignment and preload is achieved every time. This saves the installer a great deal of time compared to the more common methods used in some competitor systems.



4. CLIP FIT TOP & END CAPS

The roof installation is completed with our clip-in aluminium finishing caps, which, in keeping with the brief have been designed so fitment is intuitive, quick and straight forward whilst ensuring the smooth lines of the roof are maintained. Each of the high-quality cast aluminium cappings which cover the spa tops, boss tops and the rafter ends simply click or push into position where they are retained firmly by a suitable clip.

The design not only adds to the sleek aesthetics by completely covering any unsightly screws, but also further reduces fitting time whilst maximising security for the client.

STRONGER

Every component used in the Korniche system has been designed, developed and refined by our in-house engineering team using industry leading 3D design and analysis software. The result is a system of parts meticulously optimised to create the strongest and stiffest roof lantern assembly on the market. Unparalleled in strength, the Korniche is capable of supporting loads up to 3.5kN/m².

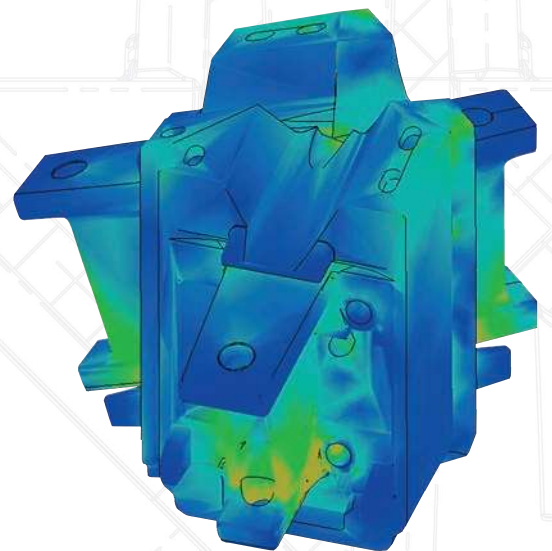
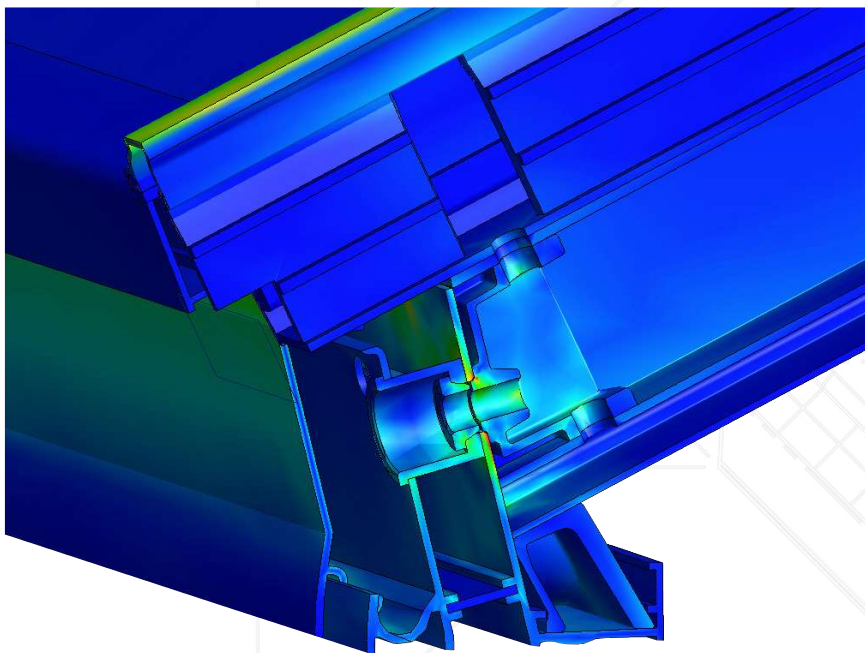

Less rafters



3.5kN/m²



Up to 6x4m

EXCEEDING STANDARDS

Having precision engineered parts connecting lightweight rigid profiles means that Korniche is an incredibly strong system from the outset, but with BBA accreditation in the pipeline we needed to be sure we could prove our roof is able to withstand the worst conditions that the UK weather can throw at it. To achieve this extensive modelling and subsequent refinement of the design using state of the art FEA (finite element analysis) software was carried out and this has resulted in our system having load bearing capabilities well in excess of the worst-cases derived from Euro code specifications.

Engineered and tested using these latest technologies we are confident that we have created the stiffest lantern roof currently on the market and to top it off Korniche can be safely supplied up to an impressive 6m x 4m.

“ I am absolutely over the moon with the Korniche lantern roof. It was easy to fit and looks very contemporary. It was everything Made For Trade said it would be. As an installer, I couldn't have asked for more. ”

Cleaver Windows



ROBUST DIE CAST ALUMINIUM LUGS & END BOSS

Patent-pending aluminium bosses make up the cornerstones of the system, these strong die cast parts have been developed to tie the roof spas and eaves beams together in such a way that forces from wind and snow loading are distributed evenly throughout the structure. High strength Helicoil inserts have been fitted at every point where aluminium parts support fasteners to protect threads and further reinforce joints.



ANTI-CRUSH TUBE

Where rafters are positioned across the ridge we have taken things one step further to ensure structural integrity will never be compromised. Back to back rafters are mirrored across the ridge body which allows us to bolt each rafter to its partner through an internal anti-crush tube. The precision turned aluminium component is perfectly machined to fit, hidden, within the ridge body profile. The resulting configuration ensures that after the die cast lugs are bolted into position the ridge section cannot deform under load. Utilising this fixing method, the usually weak link that is inherent in other systems has been designed out resulting in an incredibly strong joint with no visible reinforcement spoiling the view.



DEEP OGEE ALUMINIUM SPAS

Custom extruded 6063 T6 sections make up the lightweight, rigid beams used for the ridge, rafters and eaves. Deep structural profiles formed with internal bracing provide the required strength, and a design configuration supporting the glass high up is yet another example of how form follows function to provide great depth when viewed from below. Traditional ogee detailing is added along the lower edges to complete that clean classic feel.

WARMER

“ Well engineered, fitted without a hitch, excellent quality and support ”

Craftsman Cladding, Ayreshire



Thermal efficiency of our roof has been guaranteed by the elimination of cold bridging, this is achieved by the total isolation of the external aluminium profiles from the internal ones. When combined with high performance glazing, the Korniche's ability to reduce heat transfer is in a class of its own.

PERFORMANCE GLAZING

If delivery with glazing is required, we can offer many industry leading, high performance self-cleaning glass options. Choose from either blue, neutral, clear or aqua and with U Values ranging from 1.0 - 1.2.

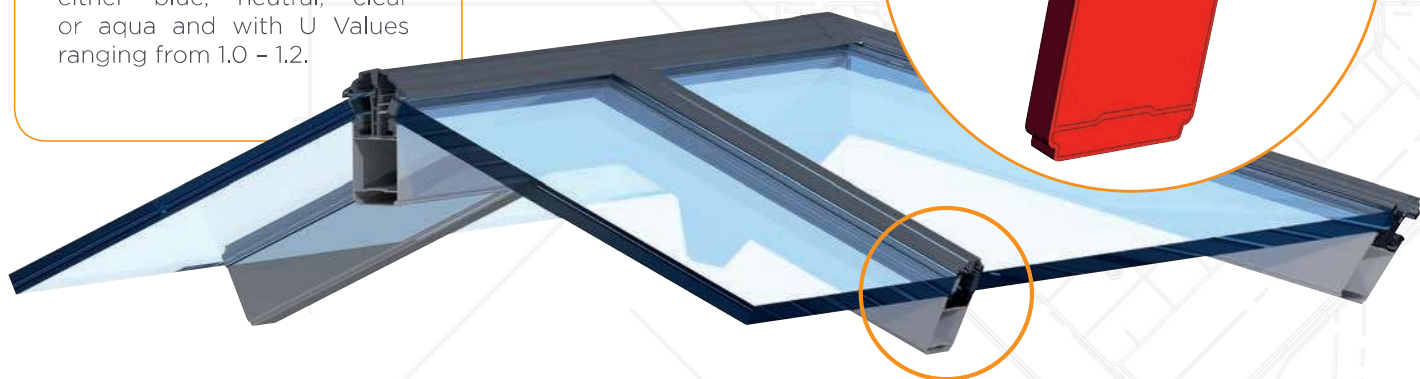

Ambience Glass

	Blue	Aqua	Ultra	Sunshade Blue	Bronze	Neutral
U Value	1.2 w/m ² K	1.0 w/m ² K	1.0 w/m ² K	1.0 w/m ² K	1.2 w/m ² K	1.2 w/m ² K
Solar Heat Reflection	60 %	82 %	91 %	80 %	55 %	60 %
Light Transmission	47 %	30 %	8 %	34 %	38 %	37 %
Self Cleaning	Yes	Yes	No	Yes	Yes	Yes



Unrivalled Thermal Efficiency



U Value from 1.2*

*U Value calculated on a 3m x 1.5m roof with 1.0 W/m²K glazing

THERMAL PVC T BAR

Thanks to the strength of Korniche being created through optimised aluminium profiles, we have eliminated the aluminium T-bar rafter used by traditional roof system manufacturers to provide structural integrity and also clip in the external cappings. Instead each of our spa and ridge body sections utilise an in-house designed high quality PVC T-bar. This section provides both the clip engagement feature for the aluminium top caps whilst being fully compatible with gold standard Q-Lon gaskets. An additional advantage in this system layout is the huge depth of thermal break created to prevent thermal bridging between outer top cap and internal spa.

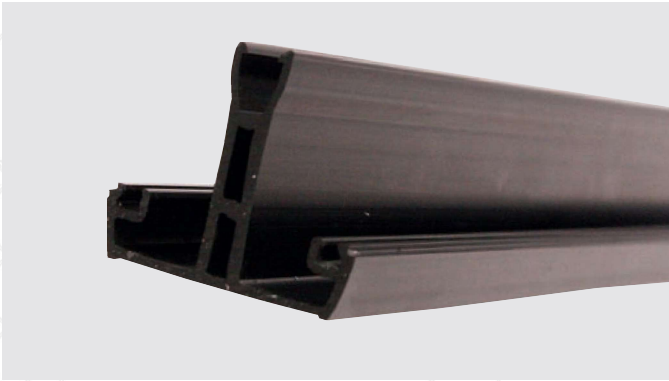

Q-LON GASKETS

Made with a unique combination of materials and with technical performance unparalleled by any other material used in weather seals. Q-Lon gaskets offers the highest standard of sealing function and are well proven even under the most extreme conditions.

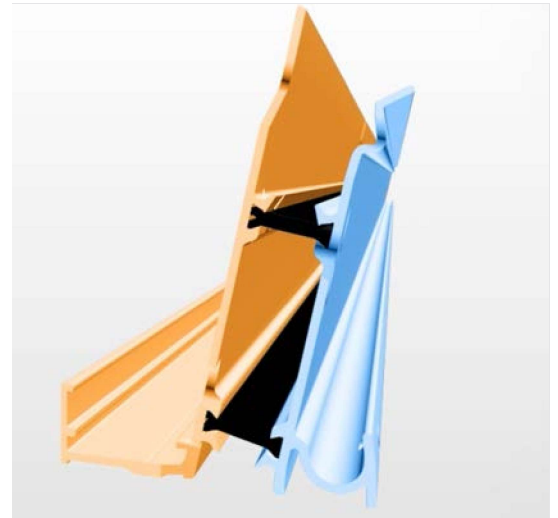

THERMALLY BROKEN EAVES BEAM

Thermal efficiency starts at the bottom of our roof. The Korniche uses eaves beams which are thermally broken using pairs of polyamide sections between the inside and outside of the profiles. These polymers create the insulated barrier between the sections of normally conductive aluminium.

INJECTION MOULDED SILICONE SEAL

To provide the last word in weather protection LSR (Liquid Silicone Rubber) injection moulded seals are factory fitted to our patent pending aluminium bosses. These create a link between the Q-Lon gaskets on the spas and ridge ensuring a complete barrier from wind and rain throughout the roof structure without the need for additional sealant. All seals come pre-located in cleverly

profiled push tabs meaning they can only sit in the correct position so no unnecessary time is ever required on site to assure alignment. Simply locate the glass and it's done



SLIMMER



The slim elegant Korniche fits perfectly in any home by retaining traditional features in a contemporary setting. The slimmest of sections are married together through carefully sculpted bosses and entirely hidden fixings to ensure that the beautiful sight-lines flow unbroken and gracefully from the ridge down through the spas

“The Korniche lantern roof is excellent quality and extremely quick and easy to assemble. Very fitter friendly and the finished look is superb.”

Ecoframes & Energy Saving Solutions

“The Korniche is very easy to put together and is an excellent product that looks very nice when installed.”

Topline Fabrications

THE SLIMMEST PROFILES

Thanks to the engineering optimisation employed during the roofs design we have been able to meet all our required criteria for structural strength whilst still offering very slender profiles. At only 57mm wide the spars and ridge sections are amongst the slimmest currently available on the market.



PATENT PENDING END BOSS

As with all of the Korniche components, our die cast ridge and spar end bosses are not just functional, their design helps to maintain the sleek aesthetics by matching the extruded profile detail perfectly, enabling the slim hips and rafters to unite almost seamlessly together without adding unsightly bulk, whatever the chosen configuration of the roof.



HIDDEN FIXINGS

Visible fixings are a thing of the past with Korniche. All the fasteners have been cleverly concealed within the spars and ridge profiles for the cleanest possible look.



UNBROKEN SIGHT LINES

A signature feature of the Korniche roof is the way that aesthetic features such as slim profiles, sculpted unions and concealed fixings all come together to provide a traditional look only thought possible with timber construction. The resulting sight lines flow gracefully and uninterrupted throughout the entire structure bringing an elegance and balance that we feel is absolutely unrivalled.

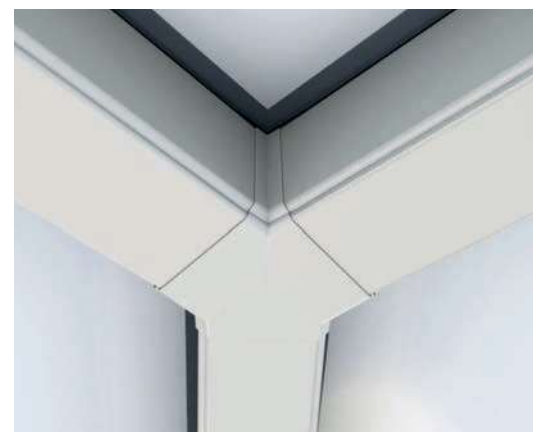

FROM BOX TO BUILT IN

3 METRE x 1.5 METRE FULLY GLAZED
LANTERN INSTALLED IN LESS THAN 30 MINUTES...



ON YOUR MARKS...



APPLYING SEALANT TO EAVES



ASSEMBLING THE SPIDER



FIXING TO EAVES



SCREWING TO UPSTAND



BOSS TOP CAPS



END CAPS

00:00
MINUTES SECONDS



CORNER BRACKETS TO EAVES BEAM



ROTATING EAVES BEAM



ASSEMBLING THE SPIDER CONT..



FITTING SPIDER TO EAVES



GLAZING UP



FITTING TOP CAPS



To view the time lapse and for more information on the Korniche Aluminium Lantern go to :

www.korniche.co.uk



Korniche®

THE DEFINITIVE LANTERN SOLUTION