

Please check contents **before** assembly. If any items are missing or damaged, **do not take the unit back to the store.** Call 1-800-427-5136 for customer service and we will save you time by correcting any problems directly for you.

BED COMPONENTS

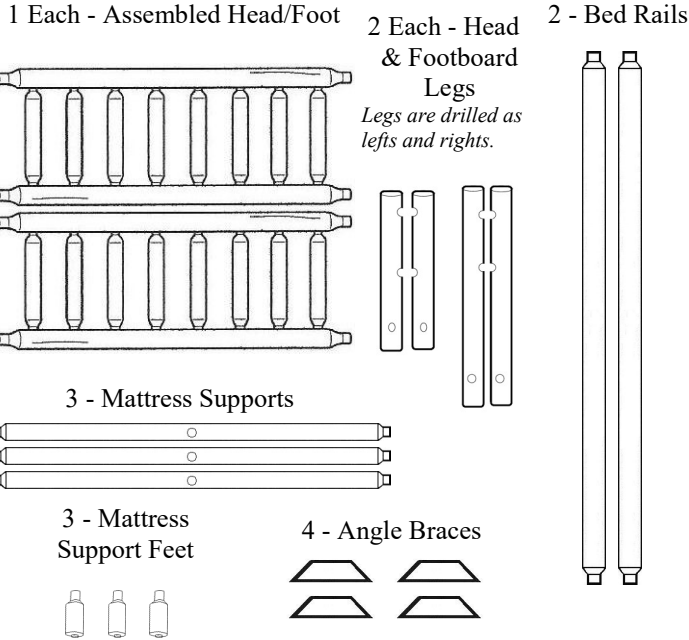

NOTE: Cracks or Checks in logs are part of the natural beauty of cedar logs and should not be considered defects.

NOTE: Read all instructions before starting.

HARDWARE & TOOLS REQUIRED

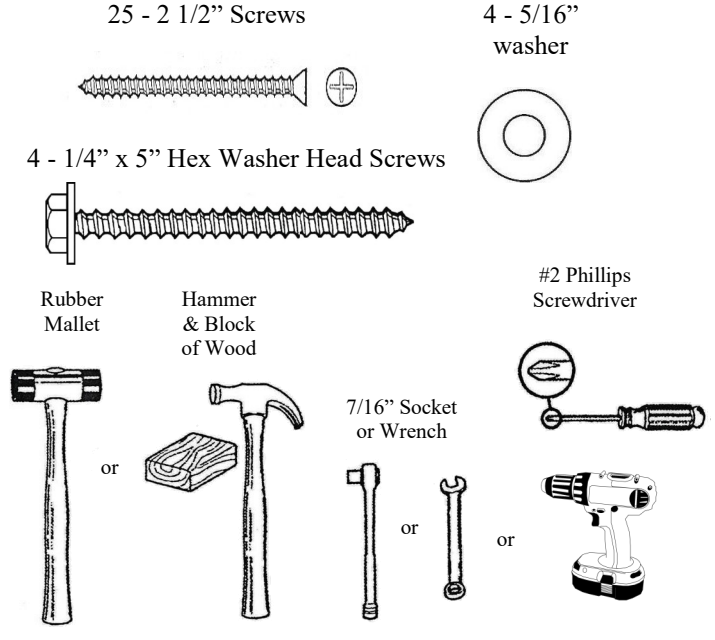

HELPFUL TIPS:

- Using a battery operated or electric drill will make assembly faster and easier.
- If finishing yourself, tape off all doweled ends. (Finishes may cause dowels to swell, making assembly difficult.).



CALIFORNIA PROPOSITION 65 WARNING

This product may have an indoor finish applied that contains Formaldehyde (50-00-0), a substance known to the State of California to cause cancer.

For more information go to www.P65Warnings.ca.gov



STEP 1 Assemble headboard by laying long headboard legs and one assembled Head/Foot board on a clean flat surface, with lower headboard leg hole facing up (recessed hole should be facing the floor) and the top holes facing inward. Use a rubber mallet or hammer and block of wood to align and insert doweled ends of the assembled headboard into the leg. Repeat process on other leg. Repeat same process for the assembled footboard. See figure 1.

STEP 2 Insert mattress support feet into each of the mattress supports. See figure 2.

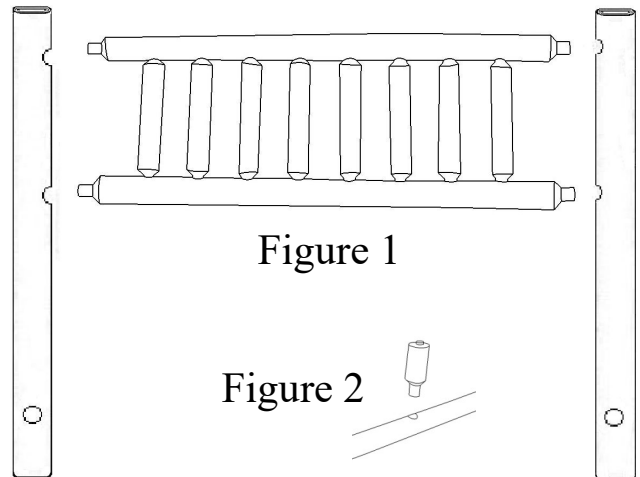

NOTE: Cracks or checks in logs are a natural phenomenon that occurs when moisture escapes as the logs dry and season. They do not affect the structural integrity of the wood and are not considered defects.



STEP 3 Assemble undercarriage by laying the bedrails parallel to each other, with holes facing inward. Using a rubber mallet or hammer and block of wood, align and insert mattress supports into the bed rails, as shown in figure 3.

Figure 3

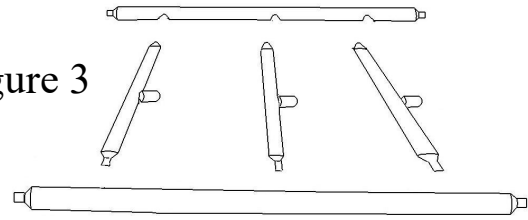

STEP 4 Align and insert the doweled ends of the assembled undercarriage into the lower holes of the headboard, (make sure support feet are facing the floor and the recessed hole is to the back). Repeat process on the footboard. See figure 4.

Figure 4

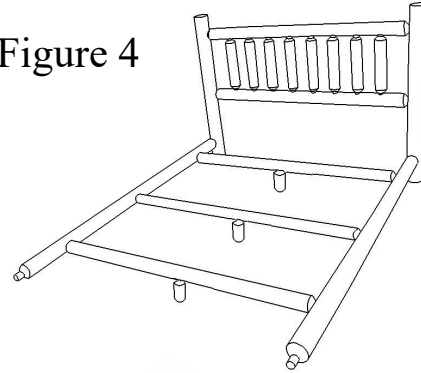

STEP 5 Secure legs to the undercarriage with 5/16" washer and 5" hex washer head screw through the four recessed holes. Secure and tighten all hex washer head screws. See figure 5.

1/4" x 5" Hex washer head screws and 5/16" washer

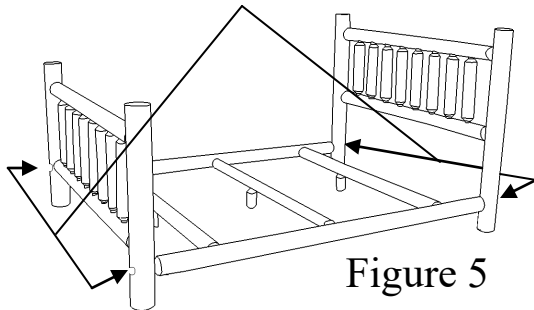
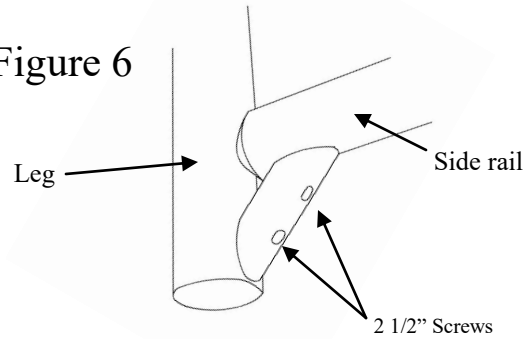

Figure 5

STEP 6 Using 2 1/2" screws, attach an angle brace to each leg and bed rail as shown in figure 6.

Figure 6



STEP 7 Secure ALL doweled joints with 2 1/2" screws. Place screws perpendicular through the dowels into the logs. See figure 7 for placement.

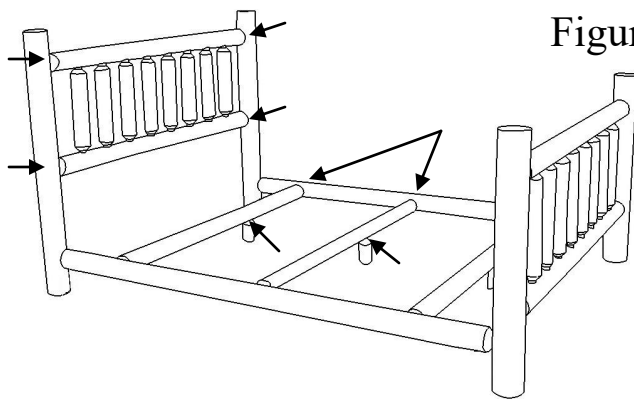
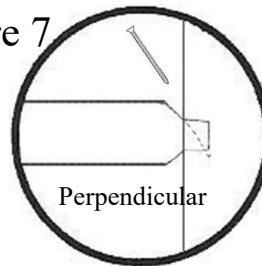

Figure 7



IMPORTANT!

If you have hardware left over after completing your unit, it most likely has been assembled incorrectly, and may not be safe to use. Please call Customer Service at 800-427-5136 for assistance.

Your bed is now assembled and is ready for immediate use or for a finish of your choice. Sweet dreams!

Check tightness periodically.

