



Aerobic Lateral Trainer



H 1000

ASSEMBLY MANUAL

THIS OWNER'S MANUAL CONTAINS ASSEMBLY, OPERATION, MAINTENANCE AND SAFETY INFORMATION. IN THE INTEREST OF SAFETY, PLEASE MAKE CERTAIN THAT YOU READ AND UNDERSTAND ALL THE INFORMATION BELOW.

IMPORTANT SAFETY PRECAUTIONS

1. Read the OWNER'S OPERATING MANUAL and all accompanying literature and follow it carefully before using your machine.
2. Inspect your exercise machine prior to exercising to ensure that all nuts and bolts are fully tightened before each use.
3. Most exercise equipment is not recommended for small children. Children should not use the machine unless they are under adult supervision.
4. Exercise equipment has moving parts. In the interest of safety, keep others, especially children, at a safe distance while exercising.
5. Warm up 5 to 10 minutes before each workout and cool down 5 to 10 minutes afterward. This allows your heart rate to gradually increase and decrease and will help prevent straining muscles.
6. Never hold your breath while exercising. Breathing should remain at a normal rate in conjunction with the level of exercise being performed.
7. Rest adequately between workouts. Muscles tone and develop during these rest periods. Beginners should work out twice a week and increase gradually to 4 or 5 times per week.
8. Remove all jewelry, including rings, chains and pins before commencing exercise.
9. Always wear suitable clothing and footwear during exercise. Do not wear loose fitting clothing that could become entangled with the moving parts of your exercise machine.
10. This machines is not intended nor warranted for any form of commercial use or enterprise. It is intended to be used for private and non-business purposes. Additionally, this equipment is only intended and only warranted to be used within the indoor enclosed spaces of a living structure and is not warranted for use in any location that is not considered "indoor space".

IMPORTANT!!! THE MAXIMUM RECOMMENDED WEIGHT CAPACITY FOR YOUR Helix is 300lbs (136kg) per user.



**The Surgeon General
has determined that
lack of physical activity is
detrimental to your health.**

WARNING: Before commencing with any exercise program, please consult your family physician.

If at any time during exercise you feel faint, dizzy or experience pain, stop and consult your family physician. In the event any of the above mentioned warnings are breached by the consumer, the manufacturer may use same as a defense to any claim for injuries, damage or loss. The above warnings are in no way intended to limit or modify the consumer's remedies for breach of warranties pursuant to applicable Federal and State Laws of Regulations. They are being supplied strictly to ensure the safety of the individuals using this product.

1	IMPORTANT SAFETY INFORMATION	2
	Important Safety Precautions	2
	Weight Limit Capacities	2
	Warning	2
2	BEFORE YOU BEGIN	3-6
	Parts Bags for 'step by step' assembly	3
	Exploded drawing	4
	Pre-Assembly Check List	5
	Unpacking Information	6
3	ASSEMBLY	7-11
4	CONSOLE	13
	Console Instructions	13-17
5	CUSTOMER INFORMATION	
	Customer Service	back cover

2

PARTS BAGS FOR 'STEP BY STEP' ASSEMBLY

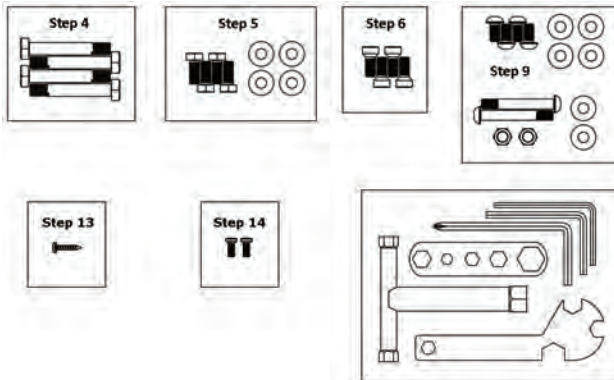

The parts required for each step of the assembly process are sorted by step in individual marked clear plastic bags. Each step has required parts and each of those parts is included with the bag printed with the assembly step.

It is recommended that these parts not be removed from the individual bags until each step of the process to avoid mixing up or confusing parts.

If you find that you are missing parts or the bag for a step is missing, please contact Helix or your dealer to receive those items. You can refer to the parts by the "step number" for ease of description.

Part NO.	Part Description	QTY
1	Left and Right Frame Legs	2
2	Pedal Frames and Covers	2
3	Main Frame	1
4	Rubber Gasket for Upright	1
5	Electronic Console Display	1
6	Center Upright Post	1
7	Left and Right Handle Bars	7
8	Console Mounting Plate	1
9	Water Bottle Holder Bolts	2
10	Pedal Frame Bolts	8
11	Computer Console Mounting Bolts	4
12	Center Upright Mounting Bolts	4
13	Handle Bar Bolts	4
14	Stabilizer Bolts	4
15	Tool(N/A)	
16	Water Bottle Holder	1
17	M8X90mm Bolt	1
18	Dome Shaped Cover	1
19	Rear End Cap	2
20	Front End Cap	2
21	Adjustable feet	4
22	Handle Bar Mounting Bolts	2
23	M8 Washer	16
24	M8 Locknut	3
25	Self-tapping bolt	1
26	Front console cover	1
27	Rear console cover	1
28	Power Adapter	1

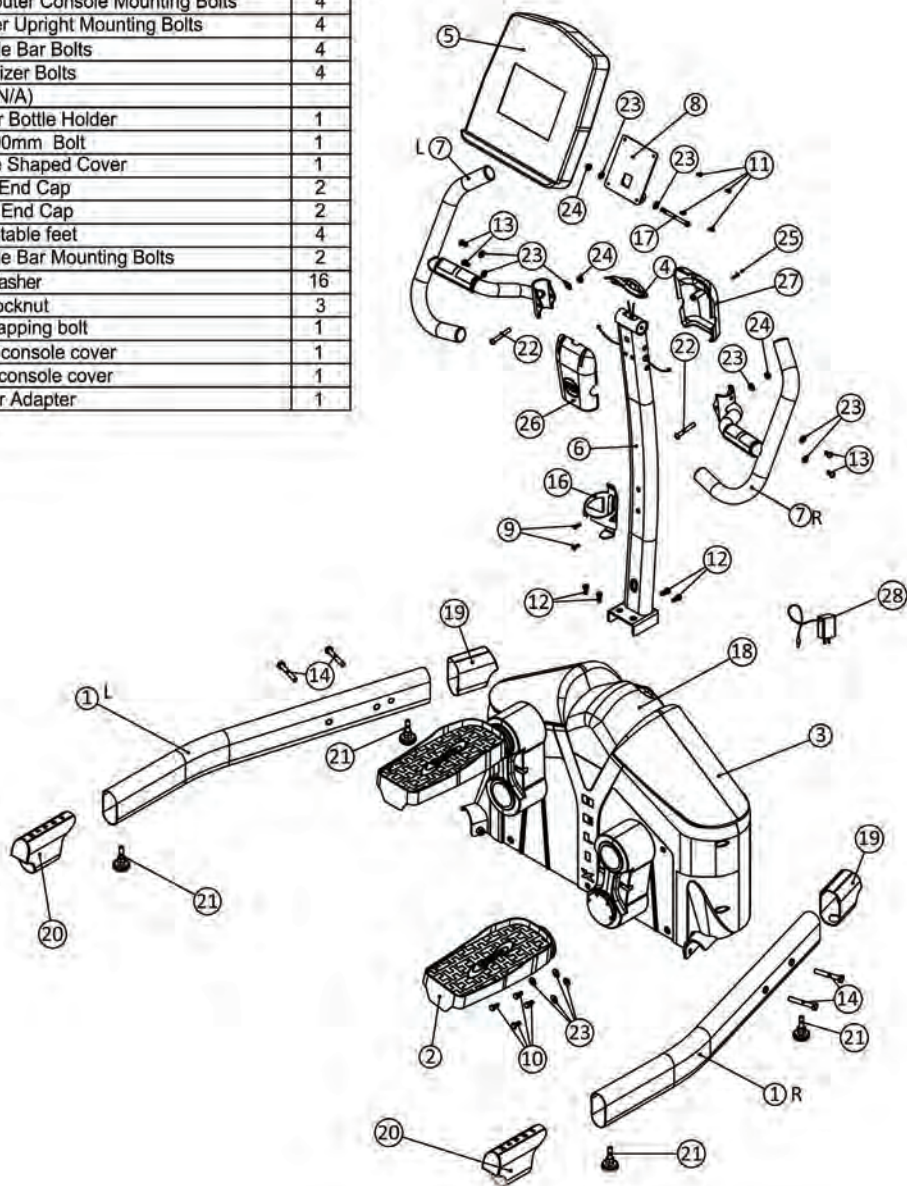

IMPORTANT: Read all instructions carefully. Assemble the Helix in accordance with the steps in the manual. All tools required for assembly are included with your Helix. Lay out all parts on the floor. Make sure that you have all the parts listed below before beginning assembly. In case of a discrepancy, please contact our Customer Service Department at the email address or customer service number listed on the back page of this Owner's Manual.

PRE-ASSEMBLY CHECK LIST

ITEM #	DESCRIPTION	QTY	ITEM #	DESCRIPTION	QTY
1.	LEFT AND RIGHT FRAME LEGS	2	13.	CENTER UPRIGHT MOUNTING BOLTS	4
2.	FRONT CONSOLE COVER	1	14.	HANDLEBAR BOLTS	8
3.	PEDAL FRAMES AND COVERS	2	15.	LEFT & RIGHT STABILIZER BOLTS	4
4.	MAIN FRAME	1	16.	ASSEMBLY TOOLS	5
5.	RUBBER GASKET FOR UPRIGHT	1	17.	WATER BOTTLE HOLDER	1
6.	ELECTRONIC CONSOLE DISPLAY	1	18.	CONSOLE MOUNTING PLATE BOLTS	4
7.	CENTER UPRIGHT POST	1	20.	DOME SHAPED COVER	1
8.	HANDLEBARS LEFT AND RIGHT	2	21.	FRONT / REAR END CAP	4
9.	CONSOLE MOUNTING PLATE	1	22.	ADJUSTABLE FEET	4
10.	WATER BOTTLE HOLDER BOLTS	2	25.	SELF-TAPPING BOLT	1
11.	PEDAL FRAME BOLTS	8	28.	POWER ADAPTER	1
12.	COMPUTER CONSOLE MOUNTING BOLTS				

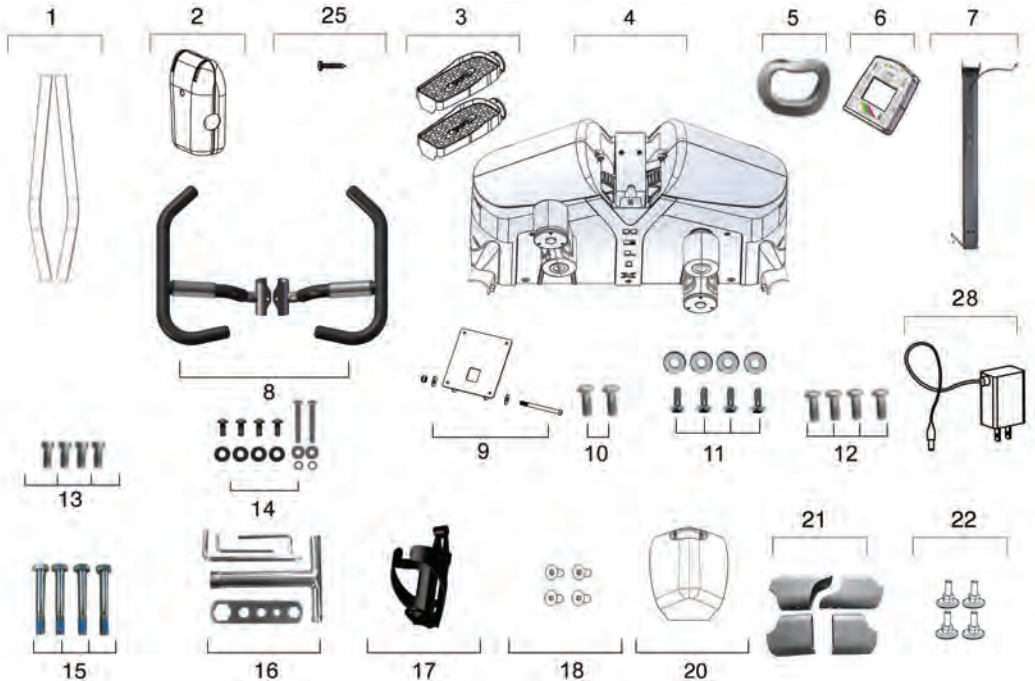

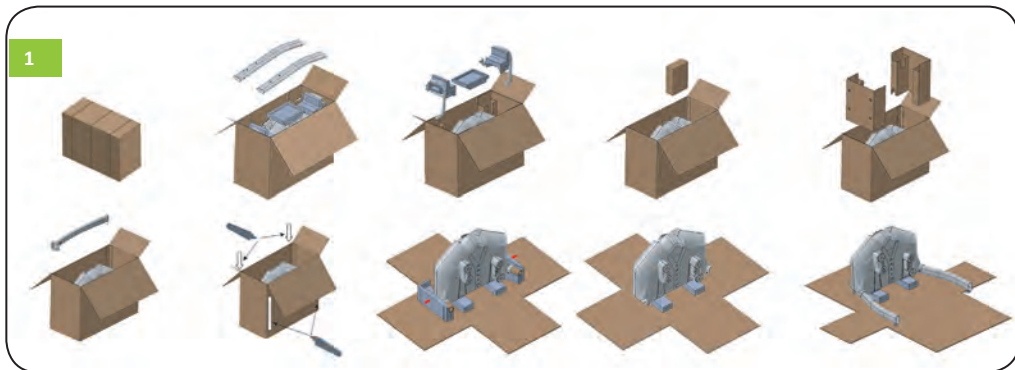
**IMPORTANT:**

Do not remove the Helix from the box bottom until further instructed later in this assembly manual.

Step 1:

Place the product near to where it is most likely to be placed after assembly. Open the box as shown above. Do not remove from the foam supports at this point. Follow instructions on the box for cutting the box to open as shown.

Step 2:

Remove all parts from the box leaving just the main body of the machine on the bottom of the box on top of the foam supports. Remove all parts and organize the Step numbered bags on the floor beside the Helix.

STABILIZERS INSTALLATION :**Step 3:**

Attach the End Caps (with HELIX branding) to the left and right stabilizers. The branded end caps install on the end farthest from the attaching bolt holes. Attach Rear End caps (no branding) to the left and right stabilizers at the end closes to the attaching bolt holes. They are front and rear specific but not left and right specific.

Install the stabilizer adjustment feet (4) into the bottom of the stabilizers and adjust as required **Figure #2.**

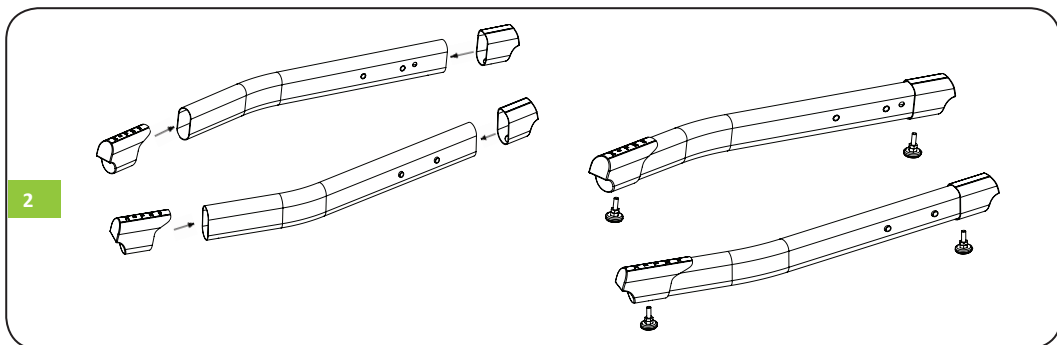

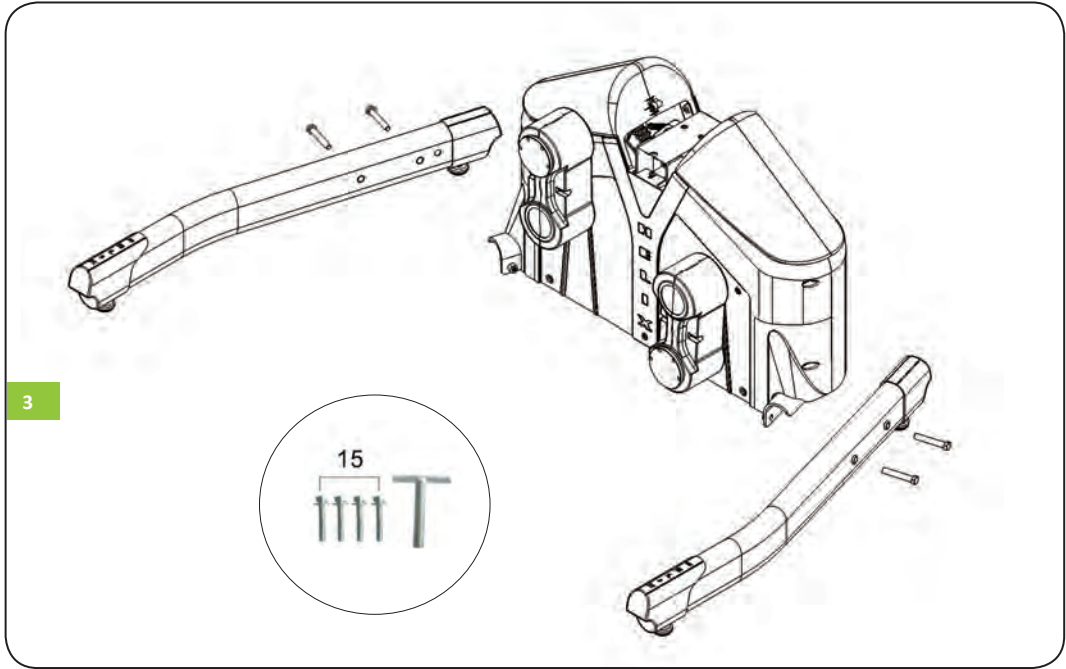
**Step 4:**

Insert the Stabilizer Leg assembly bolts into the legs and secure as shown **Figure #3**.

Tighten these bolts firmly.



If the Helix is not stable on the floor, the level can be adjusted with any of the leveling feet at each corner of the Helix

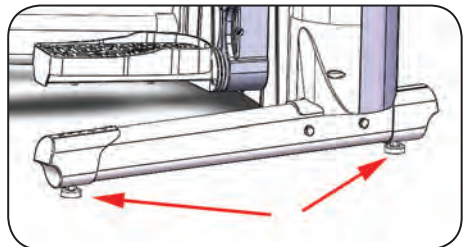

2 bolts are pre-installed

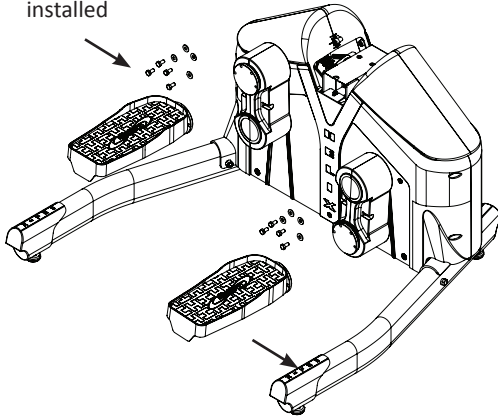

Step 5:

The pedals have two bolts pre-installed and require two Hex head bolts from the Step 5 hardware pack.

Holding the frame up to the crank arm, loosely install the lower left and lower right hex head bolts through the round pedal flange into the identical flange on the crank assembly.

This will allow the pedal to hang on the crank assembly.

Then thread the top two pre-installed bolts into the crank assembly round plate.

Continue threading all 4 bolts into the crank assembly flange until they are all snug and the flanges are flush together.

Now tighten all 4 bolts very firmly. Repeat for the other pedal assembly.

It is critical that a full visual inspection be completed to ensure that the pedal frame round flange & the crank assembly round flange & flush together and that all four bolts & completely & firmly installed.

Failure to ensure that the two flanges are firmly in contact will result in failure of the pedal frame bolts.

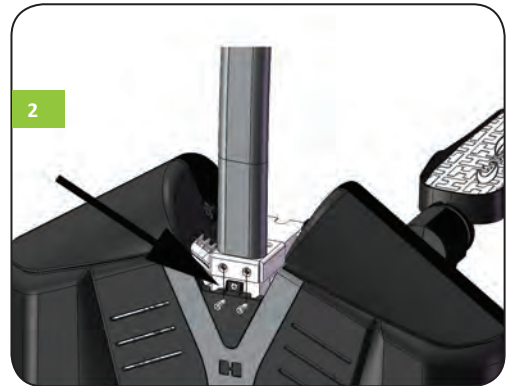
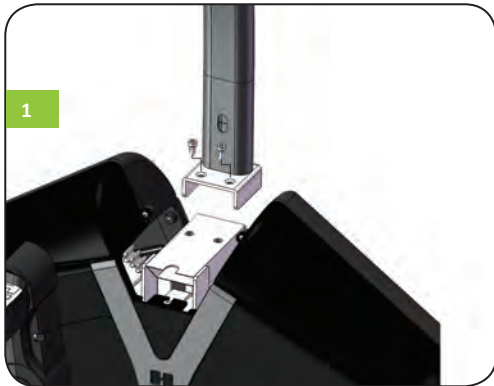

Step 6:

Place the center upright on the main body. Install the two front Allen bolts first but do not fully tighten **Figure #1**. Then install the two rear Allen bolts. After both are installed, make sure upright is level and flush with the base and fully tighten all 4 Allen bolts.

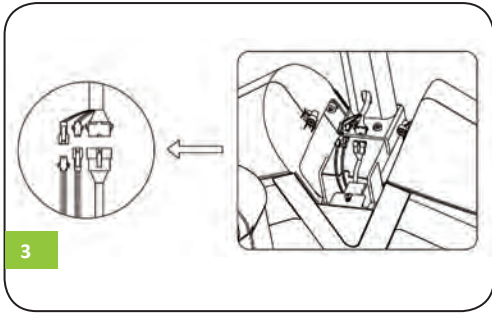

Step 7:
At the base of the main upright connect the wiring harness coming from the upright to the wiring harness coming from the main body of the Helix **Figure #3**. After these are connected, tuck the wire and connection into the upright and be sure the wire is clear of the large gears in the body.

Step 8:
Slide the cover down to the bottom of the center upright tube and fit the tabs into the holes in the lower plastic housing to fit snugly in place as shown **Figure #4**.

Apply only gentle pressure to fit the tabs and the cover in place. Slide the rubber circle down the center upright tube and push into place as shown. **Figure #5** and **Figure #6**.



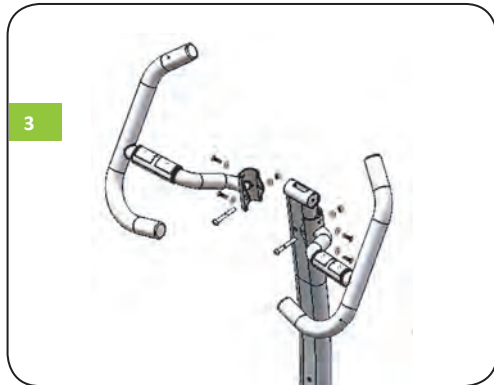
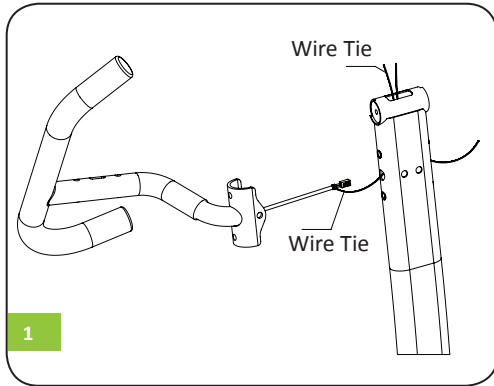

HANDLE BARS INSTALLATION :

Step 9:

Then holding one handlebar in your hand, carefully feed the pulse sensor wire into the upright and out of the hole at the top of the upright **Figure #1** above. Once the wire is out of the top of the upright, remove one of the temporary bolts and use it to secure the handlebar in place while you prepare to install the remaining 2 bolts into the handlebar on that side and secure the original long bolt from front to back. Repeat for the other side as shown above **Figure #3**.

NOTE

For ease of installation, first install two of the long handlebar bolts temporarily one in each of the holes shown above the arrow in **Figure #2** above.

Step 10:

Place console mounting bracket onto the back of the console threading the wires from the console through the center square hole. Install 4 console mounting bolts securely but do not overtighten **Figure #4**.

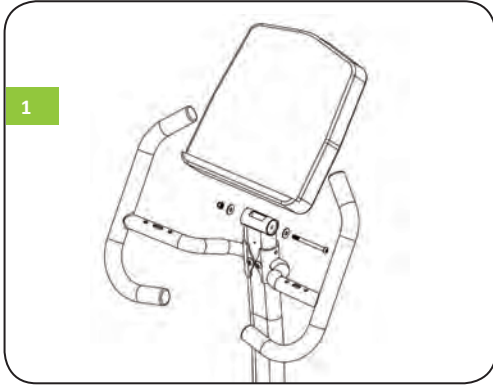
**Step 11:**

Gently place the computer mounting bracket with console onto the upright as shown above in **Figure #1**. Please take special care not to pinch the wires. Install the bolt as shown in **Figure #1** above.

Step 12:

Connect 4 wires as shown in **Figure #2** above. Excess wire can be gently feed back into the console and/or the upright post. Again, take care not to pinch the wires and leave enough excess to allow the console to adjust within pinching the wires.

COMPUTER INSTALLATION**Step 13:**

Install front and rear covers to the upright **Figure #3**. The front cover has two slots as shown. The rear cover has one bolt. Fully secure but do not over tighten .

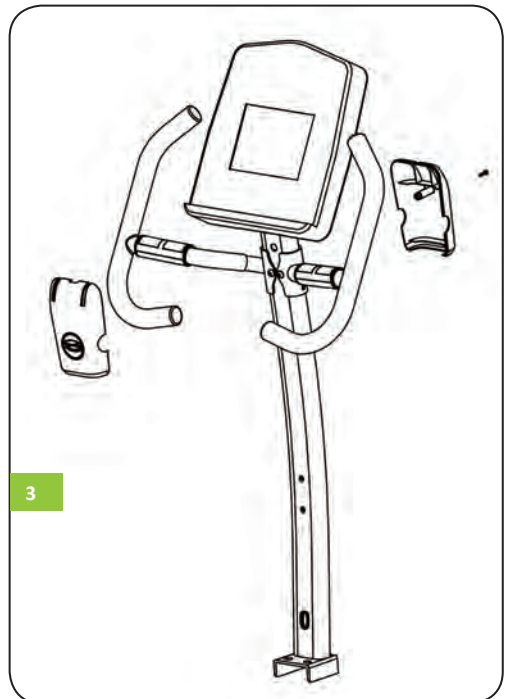

WATER BOTTLE HOLDER INSTALLATION

**Step 14:**

Find the two bolt holes in the Center Upright Post. Locate the 'Step 14' hardware bag that contains the water bottle bolts (**Figure #1**)

(**Figure #2**) Hold the water bottle holder up to the post as shown and install a bolt in the lower hole in the water bottle holder bracket (**Figure #3**) and through to the lower bolt hole on the upright.

Do not tighten at this time.

Tilt the water bottle holder upright to align the top hole in the bracket with the top hole on the center upright post. Install a 2nd bolt into that hole and then tighten with the allen key as shown in **Figure #4**.

Please read the console operation instruction thoroughly and get familiar with the console layout. Practice using this console before you start in order to get a better understanding of the functions. Below is the console layout and detailed operation instructions.

LAYOUT:

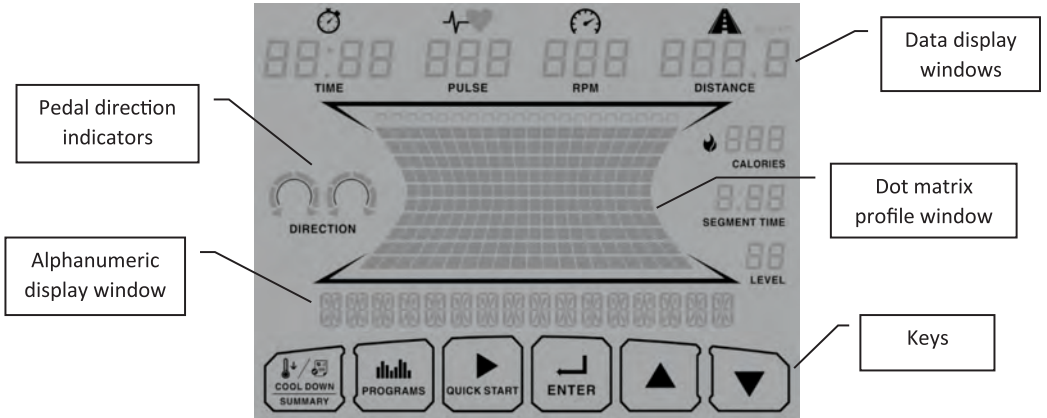

DISPLAYS

- Dot matrix profile window:**
 Displays program profile during program setting and executing. The program profile will be different according to which program is selected. Except target HR program, all other program profiles will follow below displaying rules.

There are 20 columns of LED representing 20 segments of time; each segment time = total program time divided by 20 columns. During exercising, a column of LED will blink to indicate the time segment you are currently in and show your workout progress.

There are also 10 rows of LED representing 20 levels of resistance. Each row represents 2 levels of resistance. The appropriated row of LED will light up when you adjust the resistance level.

- Data display windows:**
 There are 7 data display windows displaying “time, pulse, rpm, distance, calories, segment time and level” during exercising.
- Alphanumeric display window:**
 this display will prompt instruction messages to assist you setting up the program and during exercising.
- Pedal direction indicators:**
 This product is equipped with sensors to detect your pedaling direction and displayed with these indicators. We also designed programs built with direction change instructions to increase the intensity into these workout routines. Please follow the message display to get the most out of these programs.

instructions to increase the intensity into these workout routines. Please follow the message display to get the most out of these programs.

KEYS

- Quick Start key: Pressing this key during idle mode before you select a program will activate the Helix Interval program immediately with default user values. Or pressing this key during the program setup after a program is selected will start the selected program.
- Up/Down (▲&▼) keys: Used for user data adjusting during program setup and resistance level/heart rate adjustment while a program is running.
- Enter key: Used to confirm program and data entry.
- Programs key: Used to toggle between different programs.
- Cool down/Summary key: Pressing this key while a program is running will enter “Cool Down” mode. It is a 3 minutes cool down period. The resistance level can be adjusted from 1 – 5 at this period.

When cool down time is reached or this key is pressed again will end the program and workout summary will be displayed for your review. You can always press and hold this key for 2 seconds to reset the console and return to idle mode.

BASIC OPERATION

- Power up: Press any key to power up the console in the power save mode.
- Pause a program: If a program is running and there is no RPM for 3 seconds, the console will pause and stop accumulating data. The pause time is 3 minutes. After that, the console will reset back to idle mode. Within pause mode, pedal again to resume the program.
- Power save function: This console is equipped with power save function. If there is no RPM nor key pressing, the console screen will be off and enter power save mode.
- Start a program: To begin a workout program, press the “Quick Start” key or “Programs” key to select a program during idle mode. Then follow the instruction on the alphanumeric window to set up the personal data. When finished entering data, press the “Quick Start” key to begin the workout. (You may press “Quick Start” key anytime during setup to bypass and start the workout immediately.)
- Default values: Initially the console is coded with a set of defaults for express quick start. If you didn’t adjust these values before the program started, they will be used for data calculations, such as calories. It is recommended you adjust these values with your own personal data to get the most accurate workout feedbacks. For your convenience, each time, age & weight are adjusted, the new values will be stored as a new defaults, so you don’t have to adjust them again. However if there is more than one user for the same equipment, always double check the values during setup. The factory defaults are: age – 35; weight – 150lbs or 70kg; program time – 20 minutes and target HR – 145bpm.

if there is more than one user for the same equipment, always double check the values during setup. The factory defaults are: age – 35; weight – 150lbs or 70kg; program time – 20 minutes and target HR – 145bpm.

- End a program and review summary: Press Cool Down key once to end a program before the time is up and press it again to review the summary.
- Units switching: The default units setting is English. To switch this to Metric system, first, press and hold Up & Down (▲&▼) keys at the same time in idle mode for 2 seconds to go to “engineering mode”; second, when message window shows “UNITS: ENGLISH”, press Up/Down (▲&▼) key to switch. Afterwards press Enter key to confirm. Anytime in “engineering mode”, you may press and hold Cool Down key for 2 seconds to reset the console.

WORKOUT PROGRAMS

There are 3 program categories for your selection: Classic programs; Interval programs and HR control program.

CLASSIC PROGRAMS: This group includes Manual, Random, Simple intervals, Valley, Rolling and Mountain program.

These programs are preset profile programs and behave similar. When the desired program appears on the screen, press Enter key to confirm. Then follow the instruction to set up the user data and start the program. You may adjust the resistance level by pressing UP/DOWN (▲&▼) key during program. The dot matrix profile will update accordingly.

- Manual program: The default resistance level for Manual program is L1.
- Random program: This is a computer generated profile program and it is different each time.

- Simple intervals program profile:

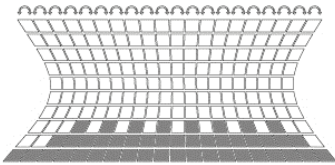

- Valley program profile:

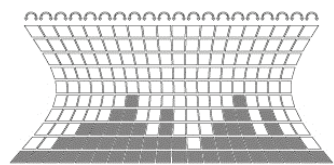

- Rolling program profile:

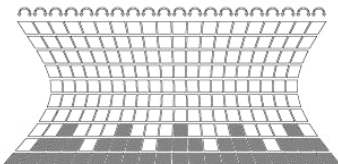

- Mountain program profile:

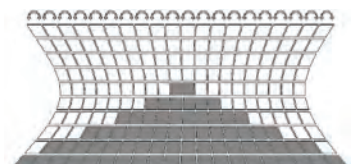

INTERVAL PROGRAMS:

This group includes Helix intervals, Ramp intervals, Pyramid intervals and HIIT intervals program.

These programs are designed to train your cardiovascular system strength by allowing your body to alternate between high intensity-work periods and low-intensity rest period. Research shows that interval training is the most effective training for fitness and burns more calories over a short period of time.

Besides intensity challenges, these programs are also equipped with pedaling direction instruction to increase variety in your workout routine. Follow the on screen instruction for the pedaling direction change.

When the desired program appears on the screen, press Enter key to confirm. Then follow the instruction to set up the user data and start the program. For your safety, these programs are started with a Warm Up period of 3 minutes. During warm up, you may adjust the resistance level by pressing Up/Down (▲/▼) key from 1 - 5.

You may press Quick Start to bypass warm up and execute program immediately. You may adjust the resistance level by pressing Up/Down (▲/▼) key during program. The dot matrix profile will update accordingly. You may start with either pedaling direction, the alphanumeric window will prompt instructions for you to change the direction as program goes on.

- Helix intervals program: This is our signature interval program and is the default Quick Start program.

Helix intervals program profile:

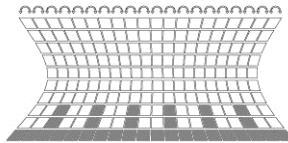

- Ramp intervals program profile:

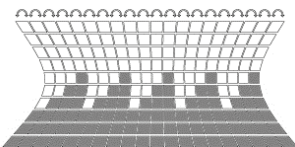

- Pyramid intervals program profile:

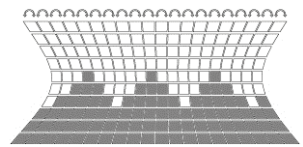

- HIIT intervals program: HIIT (High Intensity Interval Training) is considered to be much more effective than normal cardio because the intensity is higher and you are able to increase both your aerobic and anaerobic endurance while burning more fat. However the work period and recovery period ratio is crucial to achieve the effectiveness of this workout. Therefore this program time is locked and can't be changed. The default work period is 20 seconds and recovery period is 2 minutes. You may adjust the resistance level during program.

HIIT intervals program profile:

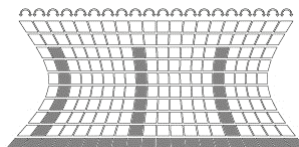

TARGET HR PROGRAM: The Target Heart Rate program is designed to keep you training at your chosen heart rate level. This program will only work when there is a valid heart rate signal. The console will adjust the resistance level automatically to ensure your target heart rate is achieved and maintained during the entire program. During program, you may press Up/Down (▲/▼) key to adjust the target heart rate setting. The profile on the Dot Matrix display will show your selected target heart rate rather than profile. The pulse data display window will show the actual heart rate. Profile:

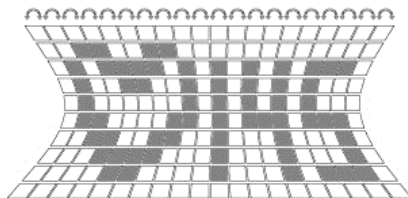

EXERCISE GUIDELINES

The American College of Sports Medicine makes the following recommendations for the quantity and quality of training for developing and maintaining cardio respiratory fitness in healthy adults:

- An activity that uses large muscle groups, maintained continuously, and is rhythmical and aerobic in nature.
- Duration: 20 to 60 minutes of continuous aerobic activity, including a warm-up and cool-down period for each exercise session.
- Frequency: 3 to 5 times per week.
- Intensity: 60% to 85% of maximum heart rate.
- In addition to aerobic exercise, it is recommended that you add strength training of moderate intensity twice per week to your program.

GET A SMART START ON EXERCISING.

Anyone over the age of 35, as well as younger persons whom are overweight, should check with his/her physician before beginning any type of exercise program. People who have diabetes or high blood pressure, a family history of heart disease, high cholesterol or have lead a sedentary lifestyle should protect themselves with a medical check-up and a stress test, preferably administered during exercise by a healthcare professional.

- Always stretch before your workout to loosen muscles, and afterwards to cool down.
- The first few minutes of your workout should be devoted to warming up muscles before a vigorous workout, and building your heart rate slowly.
- After your aerobic workout of about 24-32 minutes, spend 10 minutes gradually reducing your heart rate with a lower resistance level.

Remember, to start slow, with intensity low, until you build endurance and strength. And always consult your physician before beginning any exercise program.

For customer service, we first recommend you contact the dealer where you purchased the Helix.
They will be able to resolve any issues the fastest.

If you cannot reach the dealer, please feel free to contact Helixco at
888-Helixco or by email to service@helixco.com

Distributed under license from Kryptonite Corp by Helix Company, a division of M & S Distribution, Inc, 572
Freeport Street, Unit A, Boston, MA 02122

This product is patented in the US and other International Patents and patents pending.

US Patent Number 7,108,638

Helix® is a registered trademark of M & S Distribution, Inc. All rights reserved.