

Get started



**Download the LIFX app
for extra features.**



Your Switch.

With LIFX Switch you can control both your LIFX lights and non-smart lights all in one place either on the wall or in the LIFX app. The Switch allows you to power on/off individual lights, Groups of lights, or Scenes all with the touch of a button as you enter or leave a room.

Can't imagine lifting a finger? Set up voice control and interact with your LIFX Switch using Google Assistant or Amazon Alexa.

Dimensions.

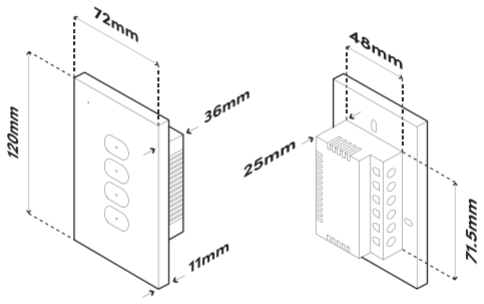

Installer instructions.

Important safety notices

- The LIFX Switch **MUST** be installed by a licensed electrician in accordance with local rules and codes
- Neutral wire required to the Switch
- Electrical power must be cut off before installation/repair
- Do not overload! Each gang is rated to 625W with a total load to the Switch of 2500W
- Must be protected by a up line 10A Type C circuit breaker



**WARNING - RISK OF OVERHEATING OR FIRE
IF THESE LIMITS ARE EXCEEDED.**

The LIFX Switch is capable of being mounted using most standard stud brackets, or mounting boxes.

With the wall mounting box and electrical wiring in place, the Switch can be installed.

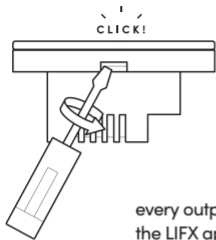

1. Open the front cover with a small flat head screwdriver.
2. Connect the wire to the terminals as needed and tighten the screws. It is not necessary to terminate every output, since the relays will be configured in the LIFX app to either be operable or latched open if configured for soft switching operations.

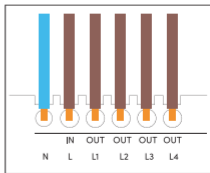
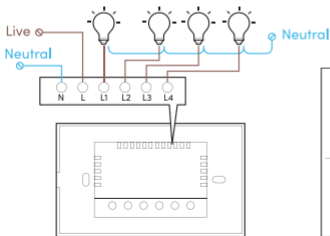

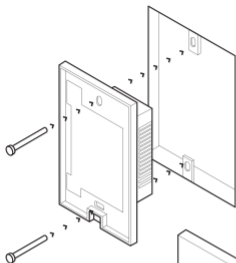

3. Once all wires are securely connected, affix the Switch chassis to the mounting bracket or box using the supplied screws as shown.

4. Reattach the face plate securely.

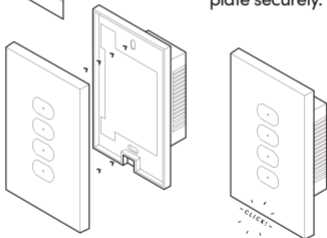

WARNING - DO NOT POWER THE SWITCH FROM THE MAIN CIRCUIT BOARD WITHOUT THE FACE PLATE SECURELY ATTACHED.

Once the faceplate has been securely attached, power the LIFX Switch circuit from the main supply. Wait 3 seconds. The backlights on the Switch buttons will be faintly illuminated indicating successful installation. Your LIFX Switch is now ready for use and configuration using the LIFX app.

User instructions.

General use

The status LED is the small light you see from time to time in the top left hand corner of the switch when it's mounted vertically (portrait alignment). By default you won't see this light, however from time to time it will come on to indicate the Switch is doing something which is not part of its normal operation. The status LED has the following codes:

- **Green, fast flashing:** A Factory Reset is complete and Switch is now in Setup Mode.
- **Green solid:** Connected to Cloud.
- **Flashing blue:** The Switch is in Reboot Mode or performing an Over-the-Air firmware update.

- **Flashing orange:** Loss of Cloud connectivity
- **Flashing red (30 second burst) :** Loss of Wi-Fi connectivity. The light will flash when the following happens: 1) Loss of Wi-Fi connectivity is first detected, 2) Every 30 mins (for 30 seconds) for the duration of loss of Wi-Fi connectivity, 3) When a button is pressed during loss of Wi-Fi connectivity.

Flashing lights will typically turn off after 60 seconds so as not to become annoying, but will come back on and flash every half an hour briefly in case nobody has noticed the error. The lights will also flash if someone presses a button and the Switch is in an abnormal state.

Common operations.

To Reboot:

Hold down the bottom button.
If your Switch is installed horizontally (or landscape) look for the button furthest away from the status LED light (see image below).

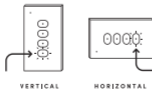

	<p>After 3 seconds the status LED will turn red and there will be a haptic pulse. Release the button within 2 seconds and the Switch will reboot. If the button is not released within this period, the Switch will return to its previous state, i.e. no reboot.</p> <p>Alternatively and if the Switch is connected to your Wi-Fi, you can use the LIFX app and go to Device Settings to perform this action.</p>
<p>To Factory Reset OR First Time Setup:</p>	<p>Important! The Switch is Factory Reset when Setup Mode is entered. Please read the next row before proceeding.</p> <p>Hold down all buttons.</p> <p>After 10 seconds the status LED will flash green and there will be a haptic pulse. This is indication that you've entered Setup Mode. Now it's time to Onboard your Switch to your Wi-Fi. Do so by doing the following:</p> <ul style="list-style-type: none"> • Release the buttons and the Switch. The status LED will now flash green to indicate it is discoverable. • Open the app and select "Add New Device" and follow the prompts to connect to the Wi-Fi network. • Once the Switch has connected to the LIFX cloud, the status LED will change to green and then turn off after 60 secs.
<p>If you've entered Setup mode and want to exit:</p>	<p>Continue holding all buttons down beyond the 10 second point</p> <p>After 15 seconds the following will happen:</p> <ul style="list-style-type: none"> • Status LED will turn off • Setup mode will be cancelled
<p>To exit Setup Mode:</p>	<p>Once in Setup Mode, press down all Switch buttons for 3 seconds. The Switch will be Factory Reset and no longer be discoverable once this is done.</p>
<p>Factory Reset (alternative):</p>	<p>If the Switch is connected to a Wi-Fi network and is shown in the LIFX app you can reset it from the Device Settings screen.</p>

FAQS

Connectivity, setup and troubleshooting

I'm running old Halogen lights. How many can I run from one Switch channel?

Each switch channel will support a total of 625W of lighting. So 12 x 50W bulbs could be connected to one channel. Simply sum up all the lights on the circuit and make sure it totals under 625W.

What type of WiFi do I need ?

Like many devices, the LIFX Switch connects to the 2.4GHz band of Wi-Fi - not 5GHz. If you have more than one available network on your router this could mean you are connected to 5Ghz and need to try your other network. Most Wi-Fi routers have a 2.4 GHz band so if you only have one network you are likely on the right one to get started.

Does LIFX Switch support 2-way control?

Yes, you can control the lights both with the LIFX Switch and the LIFX app, as well as any other LIFX compatible 3rd party integrations you have. (For clarity though, conventional 2-way control isn't supported)

Can I set a button to control another light in another room?

Yes - the buttons can be programmed to control LIFX lights anywhere in the home.

Will the Switch work if my internet connection is disabled?

Your non-smart lights will still work, but your smart lights will require internet connectivity as they will be assigned to the switch via the app. You can still however operate your Switch and LIFX lights from the LIFX app.

How do I know if my Switch has been successfully set up?

Once the Switch has successfully connected to the Wi-Fi network the status LED will turn solid green for 60 seconds before turning off.

I've set up a new network / changed my password, how do I re-connect my Switch ?

If you've changed your Wi-Fi password or set up a new router with a new password, you will need to factory reset your switch and connect it through the app as you did the first time you connected it. This is so you can assign the new, correct password for the security of the device. The configuration of the Switch should be maintained, provided it was set up using a LIFX account.

What if the power goes out?

Power outages happen. When the power comes back on, your non-smart lights will all be in the off state. LIFX lights that are wired, however, will be on.

Need more help?

Visit the LIFX Help Center at support.lifx.com

LIFX app Set-up.

1. Power on your LIFX light
2. Download the LIFX app 
3. Open the app and follow the prompts on screen.

You will need to create your LIFX account to login to the app. You will be asked to connect to your Wi-Fi network and enter your Wi-Fi password.

Technical Requirements:

A device running **iOS 12.0+** or **Android 7.0+**

A **Wi-Fi internet connection**. Wi-Fi access point must be 802.11b, g or n compliant with WPA2 security and a DHCP-configured connection available for every connected LIFX light.

Regulations & Compliance.

Specifications

To see a full list of LIFX® product specifications applicable to this Product, go to www.lifx.com/compliance

Certification

LIFX® adheres to the certification requirements for various regions around the world. To see a full list of LIFX® certifications please go to www.lifx.com/compliance to ensure LIFX® complies with the certification requirements in your region.

RF exposure warning

This equipment must be installed and operated in accordance with provided instructions and the antenna(s) used for this transmitter must be installed to provide a separation distance of at least 20 cm from all persons and must not be co-located or operating in conjunction with any other antenna or transmitter. End-users and installers must be provided with antenna installation instructions and transmitter operating conditions for satisfying RF exposure compliance.

Changes & modification

Changes or modifications made to this device may void certification of the device. Changes or modifications made to this unit not expressly approved by the party responsible for compliance could void the user's authority to operate the equipment.

Installation requirements & recommendation

The LIFX® Switch should only be installed by a qualified electrician in compliance with local electrical installation regulations. It is recommended that the LIFX® Switch be installed away from other devices designed to receive or transmit radio signals.

Interference

LIFX® has been designed to minimise interference with other radio, broadcast or receiving devices. The manufacturer is not responsible for any interference caused as a result of modifications to the product or by failure to adhere to the recommendations in this document and at support.lifx.com. This device generates radio frequency energy and, if not installed in accordance with the "recommended installation requirements" may cause harmful interference to radio communication devices. If the device is causing radio interference it is recommended that the user try:

- relocating the device to a different place;
- adjust the antenna on the receiving device;
- consult a technician experienced in radio interference.

LIFX® Switch is not designed for use in:

- Excessively hot environments (e.g. close to ovens,radiators,heaters,etc.)
- Regions or countries other than that in which the product was intended for
- Outdoor and wet areas, except where the LIFX® Product specifies that it is for both Indoor and Outdoor use

When using lifx® switch

- Isolate the power to the Switch before performing any work
- Do not open device, as this will void the warranty
- If cleaning the product, use a soft dry cloth, do not use cleaning agents

Limited Warranty

The LIFX® Switch is only certified for sale and use in Australia and New Zealand. As such, warranties, damages, and consumer protection is only available to customers using the LIFX Switch in these markets.

General

Lifi Labs Inc. ("LIFX®") warrants the LIFX® Switch(the "Product"), and only the Product, against defects in materials and workmanship under normal use ("Defect") for a period of TWO YEARS (730 days) from the date of retail purchase by the original purchaser ("Warranty Period"). Under this Limited Warranty, if a defect arises and a valid claim is received by LIFX® within the Warranty Period, at its option and to the extent permitted by law, LIFX® will either: 1. repair the Product at no charge, using new or refurbished replacement parts --or-- 2. exchange the Product with a new or refurbished Product.

In the event of a defect, to the extent permitted by law, these are your sole and exclusive remedies. A replacement Product or part assumes the remaining warranty of the original Product or ninety (90) days from the date of replacement or repair, whichever is longer. When a Product or part of the Product is exchanged, any replacement item becomes your property and the replaced item becomes LIFX®'s property. Parts provided by LIFX® in fulfilment of its warranty obligation must be used in Products for which warranty service is claimed.

Exclusions & Limitations

This Limited Warranty applies only to the Product manufactured by or for LIFX® that can be identified by the "LIFX® trademark, trade name, or logo affixed to it. The Limited Warranty does not apply to any (a) LIFX® products and services other than the Product, (b) non- LIFX® hardware product, (c) consumables (such as batteries), or (d) software, even if packaged or sold with the Product or embedded in the Product. Refer to the licenses accompanying the software for details of your rights with respect to its use. LIFX® does not warrant that the operation of the Product will meet your needs or requirements or be uninterrupted or error free. LIFX® is not responsible for damage arising from failure to follow instructions relating to the Product's use or from failures resulting from inadequate electrical supply or internet access. This warranty does not apply to a Product or

part of the Product that has been altered or modified (e.g. to alter functionality or capability) by anyone who is not a representative of LIFX® or if the Product is inserted or installed in a casing not provided by LIFX®. In addition, this Limited Warranty does not apply to Defects or damage caused by (a) use with non-LIFX® products; (b) accident, abuse, misuse, flood, fire, earthquake or other external causes or abnormal conditions; (c) operating the product outside the permitted or intended uses or conditions described by LIFX® or with improper voltage or power supply; or (d) service (including upgrades and expansions) performed by anyone who is not a representative of LIFX®. Recovery and reinstallation of software programs and user data are not covered under this Limited Warranty. This Limited Warranty does not cover the cost of returning the Product to LIFX®; this is your responsibility. No LIFX® reseller, agent, or employee is authorized to make any modification, extension, or addition to this Limited Warranty. If any term is held to be illegal or unenforceable, the legality or enforceability of the remaining terms shall not be affected or impaired.

EXCLUSIVE WARRANTIES

THE WARRANTIES SET FORTH HEREIN ARE THE EXCLUSIVE WARRANTIES PROVIDED BY LIFX®, AND EXCEPT TO THE EXTENT PROHIBITED BY APPLICABLE LAW, ALL OTHER WARRANTIES, WHETHER EXPRESS OR IMPLIED WARRANTIES (INCLUDING WARRANTIES OF MERCHANTABILITY, FITNESS FOR A PARTICULAR PURPOSE AND NON INFRINGEMENT) ARE HEREBY EXCLUDED.

LIMITATION OF DAMAGES

EXCEPT TO THE EXTENT PROHIBITED BY APPLICABLE LAW, LIFX® SHALL NOT BE LIABLE FOR ANY INCIDENTAL, INDIRECT, SPECIAL, OR CONSEQUENTIAL DAMAGES RESULTING FROM ANY USE OF THE PRODUCT OR BREACH OF EXPRESS OR IMPLIED WARRANTY OR CONDITION, OR UNDER ANY OTHER LEGAL THEORY. LIFX®'S LIABILITY FOR DAMAGES RESULTING FROM ANY USE OF THE PRODUCT OR BREACH OF EXPRESS OR IMPLIED WARRANTY OR CONDITION, OR UNDER ANY OTHER LEGAL THEORY WILL BE LIMITED TO THE ORIGINAL COST PAID FOR OF THE DEFECTIVE PRODUCT.

CONSUMER PROTECTION

Some states do not allow the exclusion or limitation of incidental or consequential damages, or allow limitations on how long an implied warranty lasts, so the above limitations or exclusions may not apply to you. This warranty gives you specific legal rights, and you may also have other rights that vary by state to state.

Australian consumer law

Our goods come with guarantees that cannot be excluded under the Australian Consumer Law. You are entitled to a replacement or refund for a major failure and compensation for any other reasonably foreseeable loss or damage. You are also entitled to have the goods repaired or replaced if the goods fail to be of acceptable quality and the failure does not amount to a major failure.

For more information visit lifx.com

LIFI LABS INC. is the exclusive owner of rights and interests in and to the mark LIFX and the LIFX logo.

Covered by patents.
lifx.com/patents

© 2021 LIFX
(LIFI LABS INC.)
All rights reserved.

Lifi Labs Management Pty Ltd
PO Box 4048, RICHMOND EAST,
Victoria, 3121, Australia



Equipment :

This symbol on the product indicates that this product shall not be treated as household waste. Instead it shall be sent to the applicable collection point for the recycling of electronic equipment. By ensuring this product is disposed of correctly, you will help prevent potential negative consequences for the environment and human health. For more information about the recycling of this product, please contact your local city office.



Not suitable for use under dust and moisture.