

***CRW900*** Water Rower  
OWNER'S MANUAL

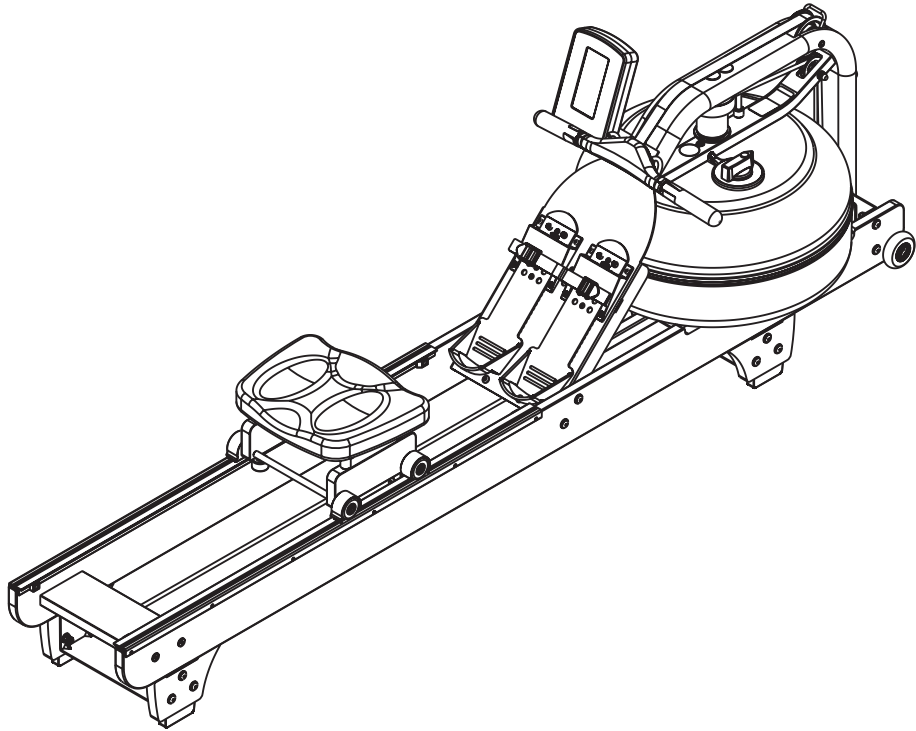

# ***TABLE OF CONTENTS***

5	IMPORTANT SAFETY INSTRUCTIONS
15	WARNING LABELS AND COMMUNICATION STICKERS
16	SAFEGUARDS
18	REGISTER YOUR PURCHASE
19	CRW900 ASSEMBLY INSTRUCTIONS
32	OPERATION INSTRUCTIONS
33	TANK FILLING & WATER TREATMENT PROCEDURES
35	ROWER BELT INSTRUCTIONS
39	ROWING FORM
40	CONSOLE OPERATION
51	ENGINEERING MODE
52	GENERAL MAINTENANCE
53	TROUBLESHOOTING
54	EXPLODED VIEWS
60	MANUFACTURER'S LIMITED WARRANTY

*Thank you for purchasing our product, please save these instructions. Please do not perform or attempt any customizing, adjustments, repair or maintenance that is not described in this manual.*



Congratulations on your new CRW900 Water Rower and welcome to the Spirit Fitness family!

Thank you for your purchase of this quality CRW900 Water Rower from Spirit Fitness. Your new CRW900 was manufactured by one of the leading fitness manufacturers in the world and is backed by one of the most comprehensive warranties available. Through your dealer, Spirit Fitness will do all we can to make your ownership experience as pleasant as possible for many years to come. If not purchased direct from Spirit Fitness, the local dealership where you purchased this rower is your administrator for all Spirit Fitness warranty and service needs. Their responsibility is to provide you with the technical knowledge and service personnel to make your experience more informed and any difficulties easier to remedy.

Please take a moment at this time to record the name of the dealer, their telephone number, and the date of purchase below to make any future, needed contact easy. We appreciate your support and we will always remember that you are the reason that we are in business.

Yours in Health,  
Spirit Fitness

NAME OF DEALER \_\_\_\_\_

DEALER PHONE # \_\_\_\_\_

PURCHASE DATE \_\_\_\_\_

# IMPORTANT SAFETY INSTRUCTIONS

## WARNING

This chapter includes precautions and fitness safeguards for the installation and use of the Water Rower manufactured by SPIRIT FITNESS. Please read this chapter carefully before installing or using your equipment. Safety instructions are provided in the following languages (in the order shown):

- English, Dutch, French, German, Italian, Portuguese, Spanish, Swedish, Chinese, Japanese

## USER SAFETY PRECAUTIONS

These safety notes are directed to you as the owner of the Water Rower manufactured by Spirit Fitness. Please train all your users and fitness staff to follow these safety instructions.

DO:

- Do encourage each of your users to discuss their health program or fitness regimen with a healthcare professional.
- Do stop operating your rower if you feel dizzy or faint.
- Do perform regular preventative maintenance.
- Do exercise slowly until you reach a level of comfort.

DO NOT:

- Do not let unsupervised children operate the rower.
- Do not use without proper athletic shoes.
- Do not use in rainy weather outdoors, or in an enclosed pool environment.
- Do not drop or insert any object, hands, or feet into any opening or within the area operation of the product.
- Do not attempt to remove any shrouds or modify the rower.

WARNING:

- Your Water Rower manufactured by Spirit Fitness is designed for exercise in a commercial or consumer environment.
- Please check with your physician prior to beginning any exercise program.
- Do not push yourself to excess. Stop if you are feeling faint, dizzy, or exhausted. Use common sense when rowing.
- Read the owner's manual in its entirety before operating the rower.
- Failure to obey this warning can result in injury or death.

SPIRIT FITNESS® and the Spirit Fitness logo are registered trademarks of Dyaco International.

## VOORZORGSMAATREGELEN

Deze veiligheidsaantekeningen zijn aan u gericht als eigenaar van de Rower manufactured by Spirit Fitness. Gelieve uw gebruikers en uw personeel voor conditietraining volledig bekend te maken met deze veiligheidsinstructies. Doe het volgende:

- Moedig elk van uw gebruikers aan hun gezondheidsprogramma of conditietherapie met een professioneel uit de gezondheidszorg te bespreken.
- Stop het gebruik van uw rower als u zich duizelig of een flauwte voelt.
- Voer regelmatig preventief onderhoud uit.
- Oefen langzaam totdat u een comfortniveau heeft bereikt.
- Gebruik de rower alleen voor zijn bedoelde gebruik, zoals in deze handleiding staat beschreven.

Doe het volgende NIET:

- Laat kinderen zonder toezicht de rower niet bedienen.
- Niet zonder gymschoenen gebruiken.
- Niet buiten bij regenachtig weer gebruiken, of in dichte ruimte met een zwembad.
- Laat geen enkel voorwerp in de rower vallen en steek uw handen of voeten in geen enkele opening van of

onder uw rower.

- Probeer geen omhulsels te verwijderen of uw rower te wijzigen.

## WAARSCHUWING:

- Uw Water Rower manufactured by Spirit Fitness is ontworpen voor aërobische oefeningen in een commerciële of gebruiker-somgeving.
- Zie uw arts vóór het beginnen van een oefenprogramma.
- Dwing uzelf niet tot buitensporige oefeningen. Stop als u zich duizelig, uitgeput of een flauwte voelt.
- Lees de gebruikershandleiding helemaal en aandachtig door alvorens uw rower te bedienen.
- Nalaten deze waarschuwing op te volgen kan letsel of overlijden tot gevolg hebben.

## PRÉCAUTIONS

Ces consignes de sécurité s'adressent aux propriétaires du Water Rower manufactured by Spirit Fitness. Veuillez instruire tous vos utilisateurs et instructeurs à suivre ces consignes. À FAIRE:

- Encouragez tous les utilisateurs à consulter un médecin au sujet de leur programme de fitness ou régime d'exercice.
- Cessez d'utiliser le roweur en cas d'étourdissement ou de faiblesse.
- Exécutez régulièrement la maintenance préventive.
- Commencez l'exercice lentement jusqu'à ce que vous atteigniez un niveau confortable.
- Utilisez le roweur uniquement de la manière prévue, telle que décrite dans ce manuel.

### À ÉVITER:

- Ne laissez pas des enfants utiliser le roweur sans surveillance.
- Ne l'utilisez pas sans porter de chaussures d'athlétisme.
- Ne l'utilisez pas en extérieur lors de temps pluvieux, ni en intérieur dans une salle de piscine.
- Évitez de laisser tomber tout objet ou d'introduire les mains ou pieds dans toute ouverture ou en-dessous du roweur.
- Ne tentez pas de retirer tout carter de protection ni de modifier le roweur.

### AVERTISSEMENT:

- Le Water Rower manufactured by Spirit Fitness est conçu pour l'exercice aérobique dans un environnement commercial ou privé.
- Veuillez consulter un médecin avant de commencer tout programme d'exercice.
- Ne vous poussez pas au-delà de vos limites. Arrêtez-vous si vous vous sentez faible, étourdi ou épuisé. Faites preuve de bon sens lorsque vous vous entraînez.
- Lisez le guide de l'utilisateur en entier avant d'utiliser le roweur.
- Le non-respect de ces avertissements peut se traduire par des blessures, voire la mort.

## VORSICHTSMASSNAHMEN

Die folgenden Vorsichtsmaßnahmen richten sich an Sie als Besitzer des Water Rower manufactured by Spirit Fitness. Bitte schulen Sie alle Ihre Benutzer und Ihr Fitness-Personal in der Beachtung dieser Sicherheitsvorschriften. GEBOTE:

- Legen Sie jedem Ihrer Benutzer nahe, sein Gesundheits- oder Fitnessprogramm mit einem medizinischen Fachmann zu besprechen.
- Beenden Sie den Betrieb Ihres rower, wenn Sie sich schwindelig oder schwach fühlen.
- Führen Sie regelmäßige vorbeugende Wartungsmaßnahmen durch.
- Trainieren Sie langsam, bis Sie eine gewisse Komfortzone erreichen.
- Verwenden Sie den rower nur zum vorgesehenen, in dieser Anleitung beschriebenen Zweck.

### VERBOTE:

- Lassen Sie den rower nicht von unbeaufsichtigten Kindern in Betrieb nehmen.
- Benutzen Sie das Gerät nicht ohne Sportschuhe.
- Benutzen Sie das Gerät bei regnerischen Witterungsbedingungen nicht im Freien und nicht in einer geschlossenen Schwimmbadumgebung.

- Lassen Sie keine Gegenstände in irgendwelche Öffnungen oder unter den rower fallen und halten Sie Hände und Füße von diesen Bereichen fern.
- Unternehmen Sie keinen Versuch, irgendwelche Abdeckungen zu entfernen oder den rower zu modifizieren

### ACHTUNG:

- Der Water Rower manufactured by Spirit Fitness ist für aerobische Übungen in einer kommerziellen oder Verbraucherumgebung vorgesehen.
- Bitte holen Sie vor Aufnahme eines jeden Trainingsprogramms den Rat Ihres Arztes ein.
- Trainieren Sie nicht übertrieben hart. Hören Sie auf, wenn Sie ein Schwäche-, Schwindel- oder
- Erschöpfungsgefühl verspüren. Lassen Sie sich beim Schrittraining von Ihrer Vernunft leiten. Lesen Sie vor Inbetriebnahme Ihres rower die Bedienungsanleitung vollständig durch.
- Ein Missachten dieses Achtungshinweises kann Verletzungen oder den Tod zur Folge haben.



## PRECAUZIONI

Queste note precauzionali sono dirette a voi, come proprietario dello Water Rower manufactured by Spirit Fitness. Siete pregati di istruire i vostri utenti e il vostro personale all'osservanza di queste precauzioni. **DA FARE:**

- Incoraggiate i vostri utenti a discutere il loro programma di salute o di fitness con uno specialista dell'healthcare.
- Interrompete l'uso dello rower se avete giramenti di testa o se vi sentite mancare.
- Eseguite periodicamente servizi di manutenzione.
- Utilizzate lo rower soltanto per l'uso è a cui è destinato, come descritto nel manuale.

### DA NON FARE:

- Non consentite a bambini di usare lo rower senza la supervisione di un adulto.
- Non utilizzate lo rower senza scarpe atletiche.
- Non utilizzate lo rower all'esterno in condizioni piovose o in un ambiente con piscina interna.
- Non lasciate cadere oggetti sullo rower e non inserite oggetti, mani o piedi in qualsiasi apertura esterna o sotto lo rower.
- Non cercate di rimuovere le coperture o di modificare lo rower.

### AVVERTENZE:

- Lo Water Rower manufactured by Spirit Fitness è stato realizzato per esercizi di aerobica in un ambiente pubblico o privato adeguato.
- Prima di iniziare un programma di esercizio fisico, consultate il vostro medico.
- Non eccedete i vostri limiti. Fermatevi se vi sentite mancare, se avete giramenti di testa o se vi sentite esausti. Usate buon senso nell'utilizzo dell'attrezzatura.
- Leggete il Manuale dell'utente interamente prima di utilizzare lo rower.
- La mancata osservanza di queste avvertenze può comportare lesioni gravi o morte.

## PRECAUÇÕES

Estas notas de segurança destinam-se a você, proprietário do Water Rower manufactured by Spirit Fitness. Treine todos os usuários e o pessoal da academia para que sigam estas instruções de segurança. ○ QUE FAZER:

- Incentive todos os usuários a discutirem seu programa de saúde ou sistema de condicionamento físico com um profissional da área de saúde.
- Pare o funcionamento do rower se sentir tontura ou vertigem.
- Efetue a manutenção preventiva regular.
- Faça exercícios lentamente até atingir um grau de conforto.
- Use o rower apenas de acordo com a finalidade para que se destina, conforme descrito neste manual.

### ○ QUE NÃO FAZER:

- Não deixe crianças sem supervisão operarem o rower.
- Não use sem os sapatos esportivos apropriados.
- Não utilize em ambientes externos quando o tempo estiver chuvoso, nem em um ambiente fechado de piscina interna.
- Não deixe cair nem insira nenhum objeto, mãos ou pés em qualquer abertura ou sob o rower. Não tente

remover nenhum degrau nem modificar seu rower.  
ADVERTÊNCIA:

- Seu Water Rower manufactured by Spirit Fitness foi projetado para exercícios aeróbicos em um ambiente comercial ou próprio do consumidor.
- Consulte seu médico antes de começar qualquer programa de exercícios.
- Não se esforce demais. Pare se sentir tontura, vertigem ou exaustão. Tenha bom senso ao fazer o exercício. Leia todo o Manual do Proprietário antes de operar o seu rower.
- Deixar de observar esta advertência pode resultar em ferimentos ou morte.

## PRECAUCIONES

Estas notas de seguridad están dirigidas a usted como el dueño de Water Rower manufactured by Spirit Fitness. Por favor instruya a todos sus usuarios y personal de entrenamiento para que sigan estas instrucciones de seguridad. **LO QUE SE DEBE HACER:**

- Dígale a cada uno de sus usuarios que discuta su programa de salud o régimen de ejercicio con un profesional de la salud.
- Deje de operar su rower si se siente mareado o como que va a desmayarse.
- Lleve a cabo mantenimiento preventivo a intervalos regulares.
- Haga ejercicio lentamente hasta que alcance un nivel en el que se sienta cómodo.
- Utilice el rower solamente para lo que fue diseñado, como se describe en este manual.

### LO QUE NO SE DEBE HACER:

- No permita que los niños operen su rower sin supervisión.
- No lo use sin zapatos atléticos.
- No lo utilice afuera en la lluvia ni en un ambiente cerrado donde haya una piscina.

- No lo deje caer ni inserte objetos. manos o pies en ninguna apertura de su rower ni debajo de él.
- No intente quitar ninguna cubierta o recubrimiento ni modificar su rower.

### ADVERTENCIA:

- Su Water Rower manufactured by Spirit Fitness está diseñado para el ejercicio aeróbico en un ambiente comercial o de consumo.
- Por favor consulte con su médico antes de iniciar cualquier programa de ejercicio.
- No haga un esfuerzo excesivo. Deténgase si se siente mareado, exhausto o como si fuera a desmayarse. Use su sentido común al hacer ejercicio.
- Lea completamente el Manual del dueño antes de operar su rower.
- El no cumplir con esta advertencia puede resultar en una lesión o en la muerte.

## FÖRSIKTIGHETSÅTGÄRDER

Dessa säkerhetsanmärkingar är riktade till dig i egenskap av ägare av Roddmaskin manufactured by Spirit Fitness. Var god utbilda alla användare och all personal att följa dessa säkerhetsanvisningar.  
MAN SKA:

- Uppmuntra alla användare att konsultera sitt hälso-  
program eller sin träningsregim med en läkare.
- Sluta använda Roddmaskin om man känner sig yr  
eller svim- färdig.
- Utföra regelbundet underhåll i förebyggande syfte.
- Motionera långsamt tills man når en komfortnivå.
- Endast använda Roddmaskin för dess avsedda  
användning, enligt beskrivning i denna handbok.

MAN SKA INTE:

- Låta barn använda Roddmaskin utan uppsikt.
- Använda Roddmaskin utan sportskor.
- Använda Roddmaskin utomhus i fuktigt väder eller i ett  
innes- lutet bassängområde.
- Tappa in eller föra in något föremål, händer eller  
fötter i någon öppning, eller under Roddmaskin.
- Försöka att avlägsna några skyddskåpor eller att  
modi- fiera Roddmaskin.

VARNINGAR:

- Din Roddmaskin manufactured by Spirit Fitness är  
avsedd för aerobisk träning i kommersiella eller  
konsumentinriktade miljöer.
- Konsultera din läkare innan du inleder något  
träningsprogram.
- Driv inte dig själv för hårt. Sluta om du känner dig yr,  
svimfärdig eller utmattad. Använd Roddmaskin med  
sunt förnuft. Läs igenom hela handboken innan du  
använder Roddmaskin.
- Underlåtelse att iaktta dessa varningar kan medföra  
skada eller dödsfall.

## 注意事項

下述安全說明適用於您所擁有的由SPIRIT FITNESS製造之水阻式划船機。請培訓所有使用者與健身人員遵守下述安全說明。

### 遵守事項:

- 鼓勵您的每個使用者在使用此水阻式划船機前，與專業的醫療保健專業人員討論他們的健康計劃或健身方案。
- 如果您感到頭暈或虛弱，請停止使用此水阻式划船機。
- 請定期進行預防性維護。
- 請緩慢且循序漸進使用此水阻式划船機，直至達到舒適程度。

### 禁止事項:

- 請勿讓無人監管的兒童操作此水阻式划船機。
- 請勿在沒有穿著合適的運動鞋的狀況下使用此水阻式划船機。
- 請勿在戶外陰雨天氣或封閉的泳池環境中使用此水阻式划船機。
- 請勿讓任何物體、手或腳掉入或插入任何開口或水阻式划船機運動範圍內。
- 請勿嘗試拆除任何零件或修改此產品。

### 警告:

- 您所擁有的由Spirit Fitness製造之水阻式划船機，專為商業或消費環境中的運動而設計。
- 在開始任何鍛煉計劃之前，請諮詢您的醫生。
- 請勿讓自己運動過量。如果你感到昏厥，頭暈或疲憊，請停止使用。使用此水阻式划船機時要運用一般常識。
- 在使用此水阻式划船機之前，請完整閱讀使用者手冊。
- 不遵守上述警告可能導致人身傷害或死亡。

## 注意事項

これらの安全に関する注意事項は、SPIRIT FITNESS社が製造したROWERのオーナーとしてお客様に向け示されています。これらの安全に関する指示や注意事項に従うように、すべてのユーザーやフィットネススタッフをトレーニングしてください。

◦ DO（行ってください）：

- 各ユーザーが各自の健康プログラムやフィットネスプログラムについて、必ず医療従事者や専門家と相談する事を強く奨励します。
- 使用前、使用中にめまいや気分が悪いと感じた場合は、直ちにバイクの使用をやめてエクササイズを中止してください。
- エクササイズバイクの定期的な予防メンテナンスを行ってください。
- 行っているエクササイズが快適に感じるまではゆっくりと運動してください。

DO NOT（行わないでください）：

- 監督なしでの子供の自転車使用を禁止してください。
- 適切な運動靴なしで使用しないでください。
- 雨天時の屋外や屋内プールでの使用は避けてください。

- フライホイールの開口部やその付近に物、手、足、指等を落としたり、入れたり、触れたりしないようにしてください。
- カバーや覆いを取り外したり、このエクササイズバイクを改造しないでください。

警告：

- このRowerはSpirit Fitness社によって製造された、業務使用目的または個人使用目的の有酸素運動用に設計されたエクササイズバイクです。
- エクササイズプログラムを始める前に必ず医師にユーザー自身の健康状態を相談してください。
- 自分自身のレベルを超えた過度なエクササイズは避けてください。わずかでも、体調不良やめまいを感じたり、疲労を感じた場合は直ちにエクササイズを中止して、使用を止めてください。エクササイズバイクの使用には適切な常識を適用する事をお勧めいたします。
- エクササイズバイクを使用する前に、取扱説明書すべてを読み理解してください。
- この警告に従わない場合は、重篤な事故、怪我や死亡に繋がる可能性があります。

# WARNING LABELS AND COMMUNICATION STICKERS

The following pages show examples of Spirit® Fitness warning labels and communication stickers placed on the equipment as part of the manufacturing process. It is critical that owners maintain the integrity and placement of these stickers. If you find any stickers missing or damaged contact your local dealer or distributor for a replacement. *NOTE: STICKERS AND LABELS ARE NOT SHOWN TO SCALE.*



**⚠ WARNING**  
**KEEP CLEAR OF**  
**MOVING PARTS**

EXERCISE WARNING STICKER

CALIFORNIA PROP 65 WARNING DECAL  
(For US model only)

**⚠ WARNING: Cancer and Reproductive**  
**Harm - [www.P65Warnings.ca.gov](http://www.P65Warnings.ca.gov)**

**SPIRIT**

MODEL NUMBER : CRW900  
CLASS : SC  
MAX USER WEIGHT : 150 kg / 330lbs  
SERIAL NUMBER : CRW90018120001

    
MADE IN TAIWAN

SERIAL NUMBER DECAL

# SAFEGUARDS

The following fitness safeguards and operating precautions are directed to purchasers and users of the Water Rower. Club Managers should ensure that members and fitness staff are trained to follow these same instructions. Failure to follow these safeguards may result in injury or serious health risk.

- Do not use any equipment in any way other than designed or intended by the manufacturer. It is imperative that equipment is used properly to avoid injury.
- Injuries may result if exercising improperly or excessively. It is recommended that all individuals consult a physician prior to commencing an exercise program.
- If at any time during exercise you feel faint, dizzy or experience pain, stop exercising and consult your physician.
- Keep body parts (hands, feet, hair, etc.), clothing and jewelry away from moving parts to avoid injury.
- Follow instructions provided in this manual for correct foot position and basic rowing techniques.
- The maximum weight for individuals riding the rower should not exceed 450 lbs (204 kilograms).
- Do not use or permit use of any equipment that is damaged and/or has worn or broken parts. For all equipment use only replacement parts supplied by Spirit Fitness.
- Cables and belts pose an extreme liability if used when frayed. Always replace any cable or belt at first sign of wear (consult Spirit Fitness if uncertain).
- Preventative maintenance is the key to smooth operating equipment as well as to keep your liability to a minimum. Equipment needs to be inspected at regular intervals.
- Ensure that any person(s) making adjustments or performing maintenance or repair of any kind is qualified to do so.
- Do not attempt to use or repair any accessory approved for use with the Spirit Fitness Equipment which appears to be damaged or worn.
- Check all belts, pulleys and bungee cords regularly for signs of wear, and replace if needed.
- Check regularly and follow all instructions for maintenance as specified in this manual.
- Replace immediately any defective parts and do not operate unit until all repairs are complete.
- Keep children away from the equipment. Parents or others supervising children must provide close supervision of children if the equipment is used in the presence of children.



- Do not allow users to wear loose fitting clothing or jewelry while using equipment. It is also recommended to have users' secure long hair back and up to avoid contact with moving parts.
- All bystanders must stay clear of all users, moving parts and attached accessories and components while machine is in operation.
- We recommend an area no less than 2ft kept clear around the rower for easier access and safety.

### **WARNING**

This product can expose you to chemicals including Toluene and Acrylamide which are known to the State of California to cause Cancer and birth defects or other reproductive harm. For more information, go to [www.P65Warnings.ca.gov](http://www.P65Warnings.ca.gov)

### **WARNING**

Do not insert fingers into tank.

### **WARNING**

After rowing exercise, please allow the unit to sit for 5 minutes before standing it up for storage.

### **WARNING**

Do not fill past the calibration mark as indicated on the tank level sticker or water spillage can occur.

### **WARNING**

Never operate this rower without feet properly secured in foot straps, or without the sliding portion of the slider footplate locked into position.

Note: Rower is not suitable for therapeutic purposes.

## **RECORD YOUR SERIAL NUMBER**

Please record the serial number of this fitness product in the space provided below (serial number is located on the center floor tube behind the crank).

Serial Number:

## **REGISTER YOUR PURCHASE**

The self-addressed product registration card must be completed in full and returned to Spirit Fitness. You can also go to <https://www.spiritfitness.com/commercialwarrantyregistration.html> under the "Support" tab to register online.

# CRW900 PRE-ASSEMBLY

---

Use the following procedures to unpack and assemble your water rower manufactured by Spirit Fitness:

1. Position the shipping carton so the heavy end is located at the bottom.
2. Cut the straps then lift the box over the unit and unpack. Remove foam inserts and all parts from the shipping carton, then use the parts list to verify that all parts are included in your shipment.
3. Locate the hardware package. The hardware is separated into steps. Remove the tools first. Remove the hardware for each step as needed to avoid confusion. As you read through the assembly instructions, any number that is in brackets [#] refers to the item number from the corresponding assembling drawing.

*NOTE: All tools required to assemble the rower are included within the packaging.*

*NOTE: If you are missing any of the parts listed above, inspect the packing material and the box for items that may have been overlooked.*

*If parts are missing, or if you have any operational questions, please call your local Spirit Fitness's service department or the distributor whom sold you the product. Please see the back of the manual for a listing of international corporate offices and locate the office nearest you. Have your serial number ready.*

*CAUTION: Damage to the rower during assembly is not covered as part of the limited Spirit Fitness warranty. Take care not to drop or lean the rower on its side. Carefully stand the rower up in the normal upright position on a stable surface so it will not tip over during assembly.*

*Protect the environment by not disposing of this product with household waste. Check your local authority or approved waste center for recycling advice and facilities.*

# CRW900 BOX 1 & 2 CONTENTS

Item	Qt.	DESCRIPTION
1	1	MAINFRAME
2	2	LEFT/RIGHT SIDE RAIL
3	1	ROWER SEAT
4	1	REAR BRACE
5	1	BUNGEE HOOK MOUNT
6	2	TRANSPORT WHEEL ASSEMBLY
7	40	M8 WASHER
8	20	M8 STANDARD NUT
9	20	M8 NYLOC NUT
10	4	M6 X 15MM BOLT
11	20	M8 X 45MM BOLT
12	1	5MM ALLEN KEY
13	1	6MM ALLEN KEY
14	1	13MM WRENCH
15	4	AA BATTERY
16	1	WATER TREATMENT TABLETS
17	1	SIPHON
18	1	TOUCH UP PAINT

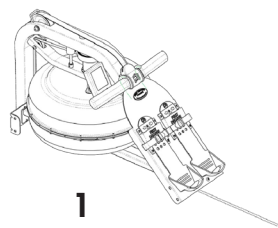

1

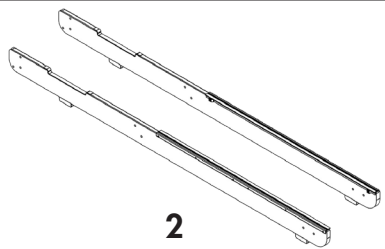

2

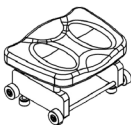

3

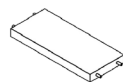

4



5

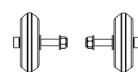

6



7



8



9



10



11



12



13



14

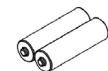

15

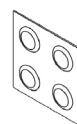

16



17

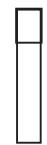

18

# CRW900 PARTS

Item	Qt.	DESCRIPTION
19	1	BUNGEE SHOCK CORD [Pre-installed on Mainframe]
20	4	SEAT SPACERS
21	1	FOOTBOARD [Pre-installed on Mainframe]
22	2	FRONT AND REAR SUPPORT BRACKETS
23	4	ELEVATED LEGS
24	8	M6 X 20MM BOLT
29	1	HEART RATE RECEIVER
30	3	CABLE TIES
31	3	CABLE TIE MOUNT
32	1	ADJUSTMENT KNOB

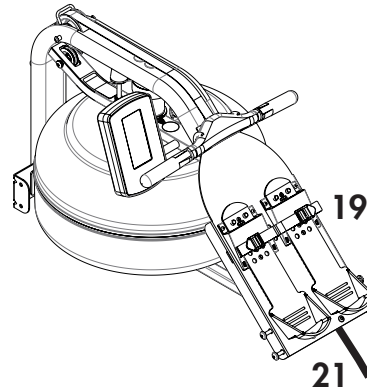

20

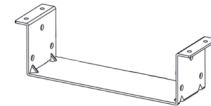

22

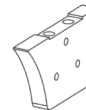

23



24

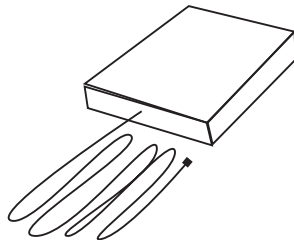

29

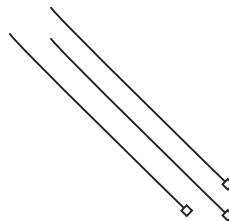

30

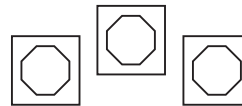

31

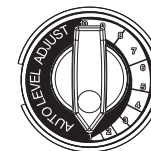

32

# CRW900 1 - REAR BRACE, TRANSPORT WHEEL

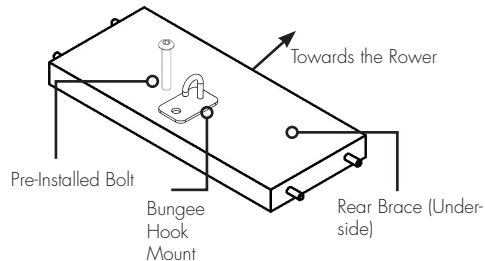

REQUIRED PARTS
SIDE RAIL LEFT / RIGHT [2]
REAR BRACE [4]
BUNGEE HOOK MOUNT [5]
TRANSPORT WHEEL ASSEMBLY [6]
4 X M6 X 15MM BOLTS [10]

1. Start with the **Rear Brace [4]** and on the underside you will find a pre-installed bolt, remove the bolt. From the hardware kit, take the **Bungee Hook Mount [5]** and install it onto the **Rear Brace [4]** as shown. Please note the orientation of the **Rear Brace [4]** and **Bungee Hook Mount [5]** must be correct in order to hold the end of the **Bungee Shock Cord [19]** as depicted by the arrow in the illustration, which points toward the front of rower.
2. Rotate the **Rear Brace [4]** to correct orientation before assembling onto **Side Rails [2]**.

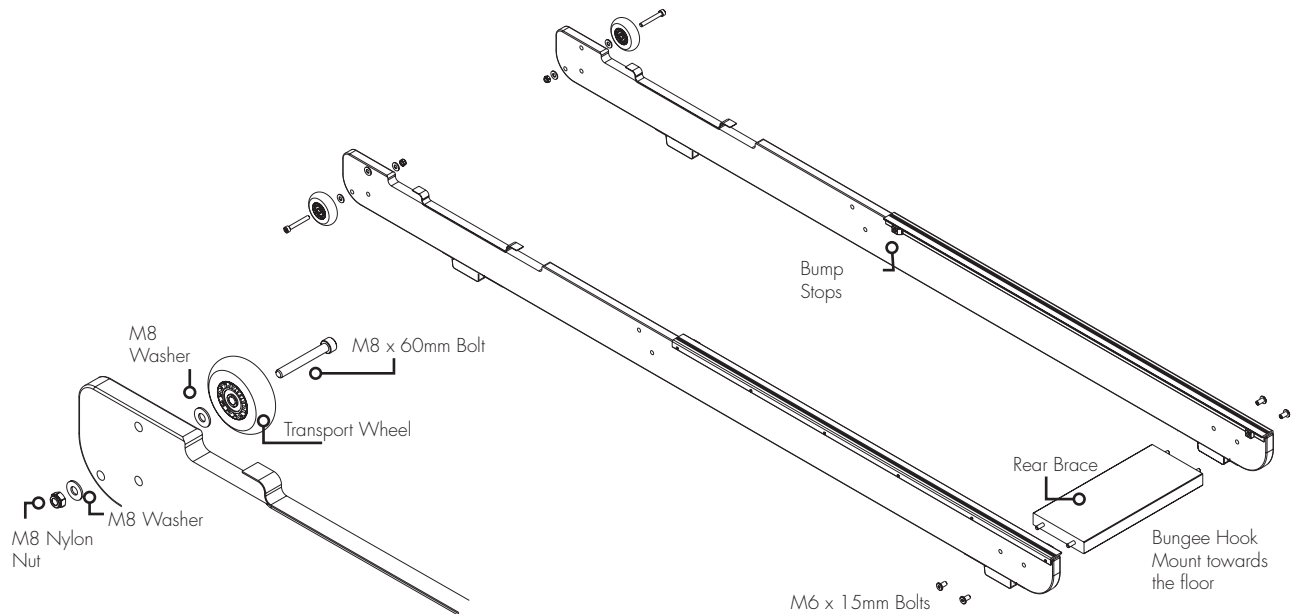

1. Next, connect the **Left/Right Side Rails [2]** using 4pcs **M6x15mm Bolts [10]** and **Rear Brace [4]**. **DO NOT TIGHTEN**. *Note: The "Bump Stops" should be facing towards each other for proper assembly.*
2. Once the **Rear Brace [4]** and **Side Rails [2]** are assembled, mount the **Transport Wheel Assembly [6]** onto the **Left/Right Side Rails [2]** using the **M8 x 60mm bolt [pre-installed]**, **M8 washers [pre-installed]**, **Nylon nut [pre-installed]**, & **Transport Wheel**.  
*Note: Place one M8 Washer [pre-installed] on the outside and one M8 Washer [pre-installed] on the inside of the rail when mounting the **Transport Wheel [6]**.*
3. The **Transport Wheels [6]** must be mounted on the outside of **Side Rails [2]** as shown. Do not over tighten the transport wheel axle as it may inhibit **Transport Wheel [6]** rotation.

# CRW900 2 - INSTALLING THE SEAT

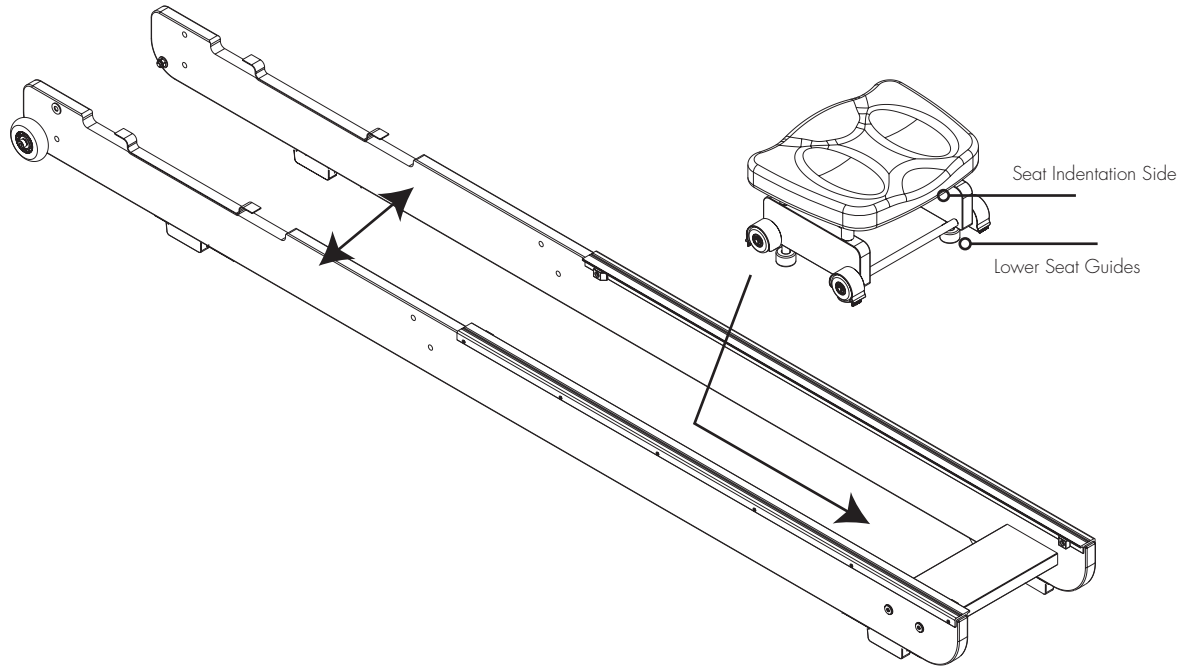

1. To install the **Rower Seat [3]**, spread the **Left/Right Side Rails [2]** slightly and drop the **Rower Seat [3]** into the track. Make sure to fit the lower seat guides into the track. It will be sitting somewhat loosely on the track until the **Mainframe [1]** is installed. *Note: Seat indentation must face rearward as noted in the illustration above.*



# CRW900 OPTION FOR THE SEAT HEIGHT

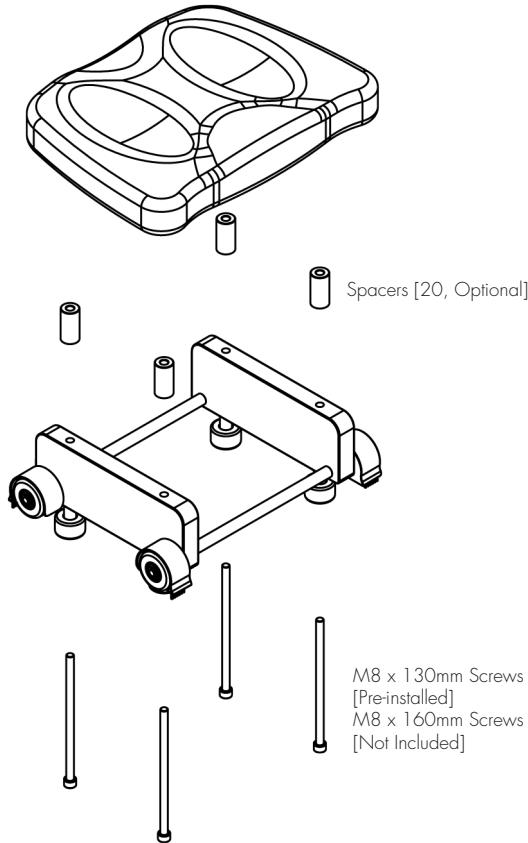

The **Rower Seat [3]** comes fully assembled, however the cushioned seat can be mounted at various heights for added comfort and usability. The use of **Spacers [20]** is optional.

To mount the seat in a higher position, remove the pre-installed 4pcs of M8 x 130mm screws and the cushioned rower seat. Place the **Spacers [20]** in between the cushioned rower seat and the seat frame before using 4pcs of M8 x 160mm screws (not included) to secure everything in place.

Keep the 4pcs M8 X 130mm screws removed from the seat if you ever want to return the seat to its original (lower) position in future.

# CRW900 3 - MAINFRAME

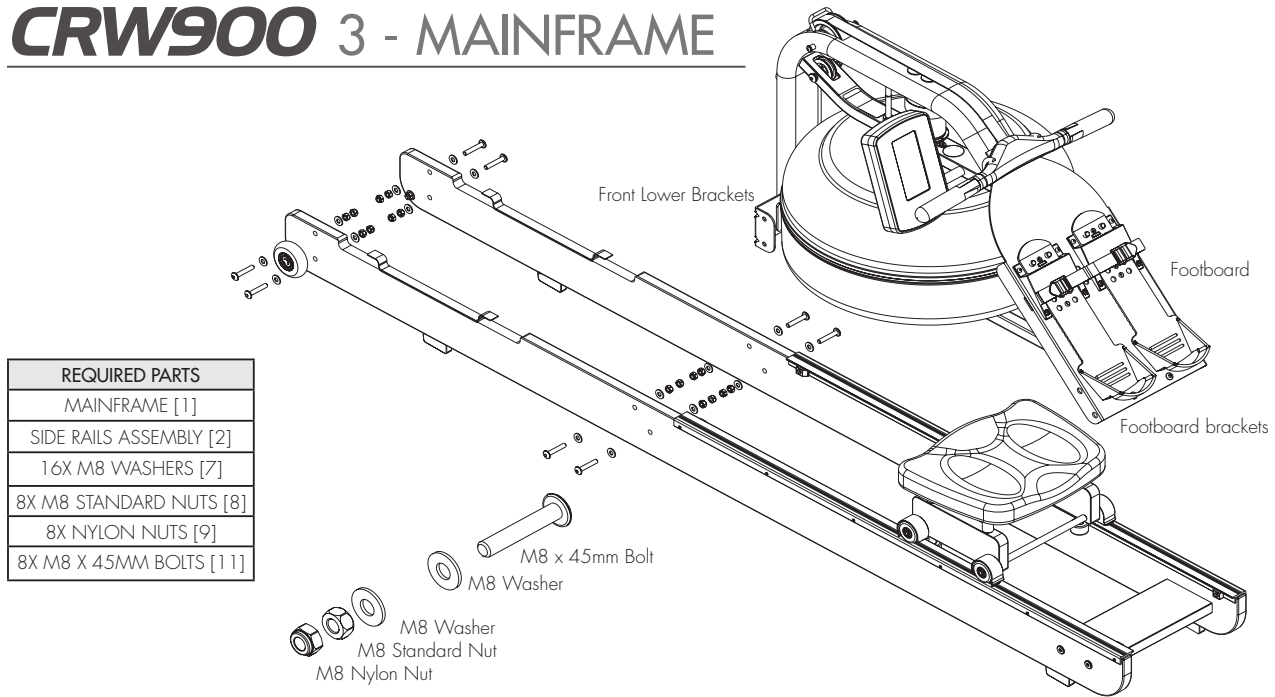

1. Install the **Mainframe [1]** onto the **Side Rail Assembly [2]** . You will need 8pcs **M8x45mm Bolts [11]** , 16pcs **M8 Washers [7]** , 8pcs **M8 Standard Nuts [8]** and 8pcs **M8 Nylon Nuts [9]**.
2. Secure the front most lower bracket first, then the footboard brackets but **DO NOT TIGHTEN**. You may find that the footboard bracket bolts can be difficult to access. Simply align and loosely thread lower bolts and nuts during this step. (Once the rower is standing in the vertical position in Step Four, these bolts can be tightened.)

*Note: Clean wheels & tracks weekly with a soft dry cloth in order to decrease the rate of wear on both wheels and track.*

# CRW900 4 - ATTACHING THE BUNGEE CORD

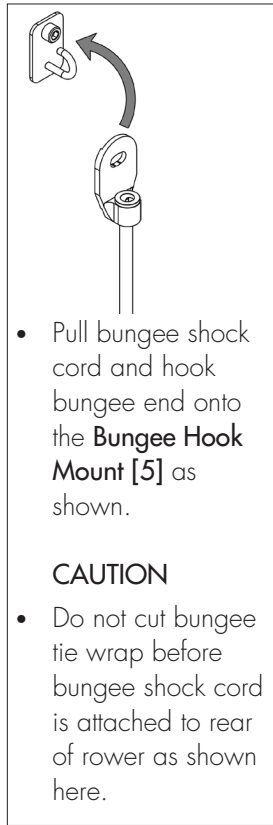
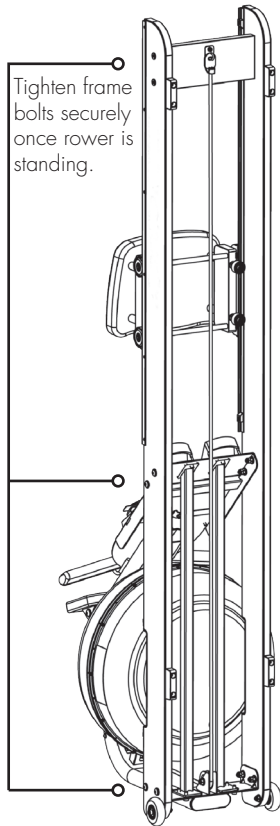

1. Once the **Bungee Shock Cord [19]** is attached to the **Rear Brace [4]**, tighten the bolts holding the **Footboard [21]**, the **Mainframe [1]** to side rail bolts as they are easier to access from the vertical position.
2. Lower the rower back to the horizontal position and test for proper bungee recoil.
3. Check seat rollers/runners for dirt or debris before sitting on the rower seat. Small objects captured between the seat rollers and runners can damage the wheels or running surface. Check runners for debris prior to each use and clean regularly.  
*Note: The rower frame bolts require periodic checking for tightness. Do this at the end of the first month of use and again every 12 months*
4. The rower frame can be polished with any high grade furniture polish to further highlight the rich luster of the wood finish.
5. Install supplied **2 AA batteries [15]** and check computer function. Further details regarding console operation can be found in the "Computer" section of this manual on page 45.
6. Choose a flat, level surface on which to use your rower, to avoid rocking and potential premature wear.

# CRW900 5 - BUMPERS AND ELEVATED BRACKETS

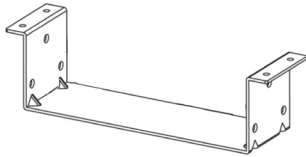

Front and Rear Support  
Brackets [22] - 2pcs

1. Stand the Rower Vertically
2. Remove the M6x20mm Bolts [pre-installed] and the front and the rear bumpers from **Left and Right Rail** [2].

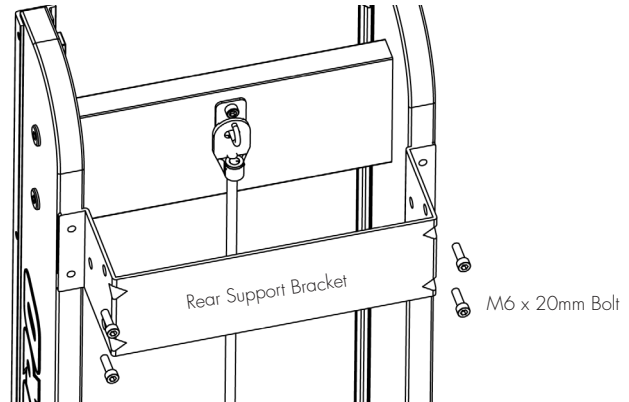
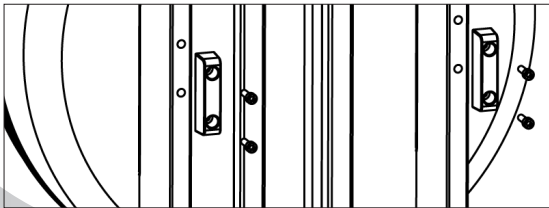
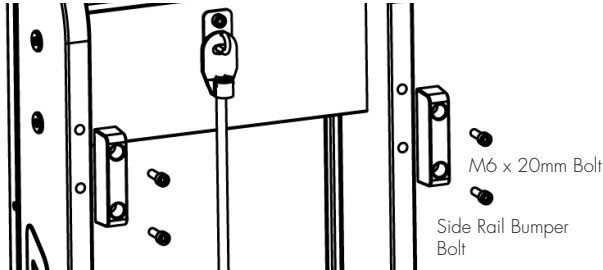

1. Mount the **Front and Rear Support Bracket** [22] as pictured. Insert and secure with the 4pcs **M6x20mm Bolt** [24].

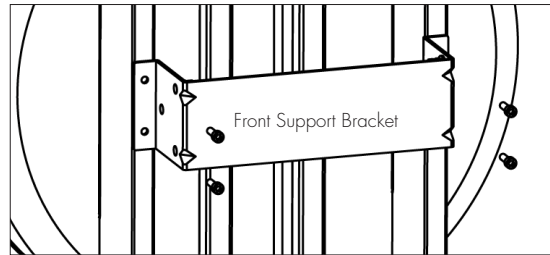

# CRW900 5 - CONTINUED

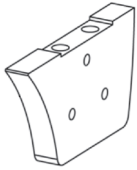

Elevated Leg [23] - 4pcs

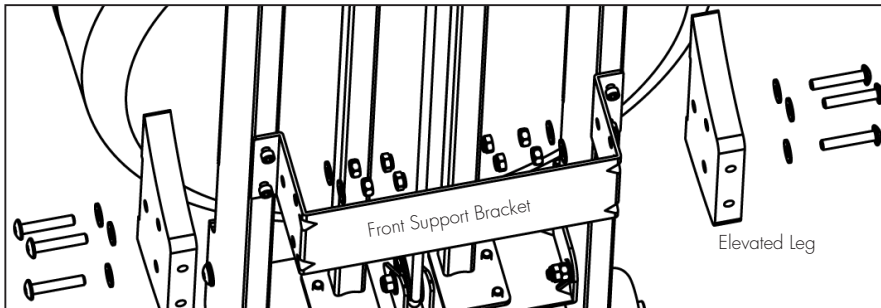
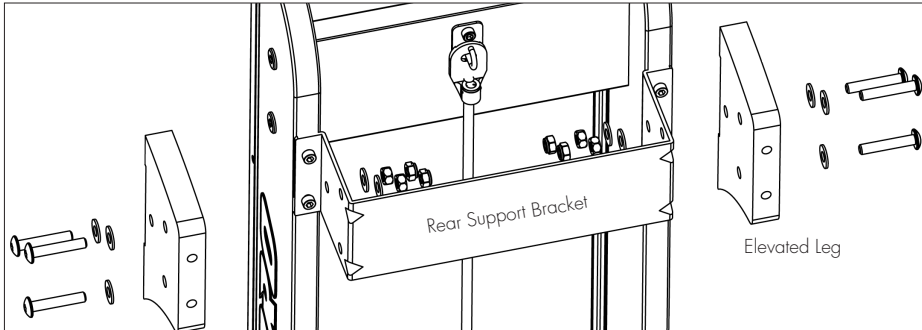

1. Mount the **Elevated Leg [23]** as pictured. Align the **Elevated Legs [23]** with the bolt holes and secure them all with 12pcs **M8x45mm Bolt [11]**, 24pcs **M8 Washer [7]**, 12pcs **M8 Nut [8]** and 12pcs **M8 Nylon Nut [9]**.

*CAUTION: The arched sides of the legs should face the middle of the rower as shown.*

2. Reinstall the bumpers to the bottom of the **Elevated Legs [23]** with the previously installed M6 x 20mm Bolts (as shown on page 28).

# CRW900 HEART RATE INSTALLATION

## REQUIRED PARTS

HEART RATE RECEIVER [29]

3PCS CABLE TIES [30]

3PCS CABLE TIE MOUNTS [31]

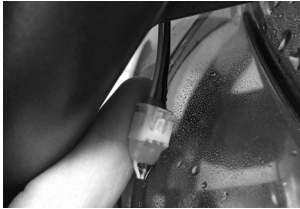

1. After confirming all parts are present. Find the flying lead cable on the **Mainframe [1]** of the rower just behind the upper **Footboard [21]** and attach the harness.



2. Run the wire under the **Footboard [21]** to the side rail.

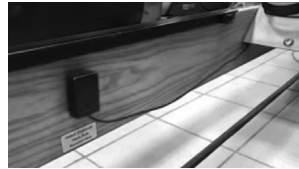

3. Paste the **Heart Rate Receiver [29]** to the location as indication label using double-sided tape, and please be aware on the direction, keeping the wire in the downside.

*Note: Don't affix permanently until signal in this location is tested. Mount the Receiver low enough to avoid the lower Seat Rollers.*

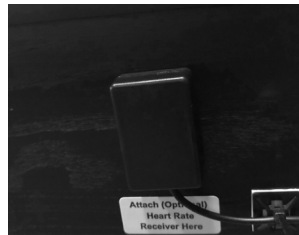

4. Use the **Cable Tie Mounts [31]** to secure the wiring out of the way of any moving parts. Trim excess.

# **CRW900** HEART RATE INSTALLATION

---

- You will have an excess of wire which you can tuck out of the way behind the metal frame bracket.
- Maintaining a consistent signal on a rower can be a challenge due to the varying distances experienced during the rowing stroke between the receiver/transmitter.
- If you are experiencing difficulty, make sure the batteries on your chest belt or other device are fresh, and that the frequency of your transmitter is 5.3 KHz.
- Environmental conditions, as well as proximity to other machines can also interfere with a clean signal. Feel free to experiment moving the heart rate receiver into different positions for best performance.

# OPERATION INSTRUCTIONS

The CRW900 Rower's water tank offers a true multi-level experience. Water is moved between the "storage" and "active" chambers of the tank. Your new rower can adapt at the turn of a dial to the resistance preferred by each user in the home environment.

## GETTING STARTED

To achieve minimum resistance, select "MIN" on the tank adjuster. It takes 10 strokes to fill the central "storage" tank, leaving a minimal amount of water in the outer "active" tank. This process is always required if minimum resistance is desired. Rowing at a steady pace (20 to 25 strokes per minute [SPM]) and putting effort into the stroke, ensuring that good form is maintained. You can make adjustments to the resistance level while you row. Your rower will adapt almost instantly to increases in resistance but will take up to 10 strokes to reduce the effort required, as the central "storage" tank fills up.

## DEVELOPING YOUR ROUTINE

Once you have found a level that gives you the desired challenge, changes can be made to SPM and to stroke intensity to further vary your workout intensity. Interval training is used by most rowers, where a period of low intensity is combined with short intervals of high intensity. Your SPIRIT Rower allows for changes 'on the fly', to achieve multi-level resistance profiles during a single workout.



# TANK FILLING & WATER TREATMENT PROCEDURES

1. Remove rubber fill plug from the top of the tank.
2. Place a large bucket of water next to the rower. Position the **Siphon [17]** with rigid hose in the bucket, and flexible hose in the tank.  
*Note: Make sure small breather valve on siphon is closed before filling.*
3. Set **Adjustment Knob [32]** to "10". Squeeze siphon to begin filling. Do not overfill tank.
4. When full, open the valve on the top of the siphon to allow excess water to escape.
5. Once filling is completed follow the water treatment schedule below, then replace the tank plug.

## INITIAL WATER TREATMENT

Add 1 x **Water Treatment Tablet [16]** per full tank.

DO NOT, UNDER ANY CIRCUMSTANCE, USE A WATER TREATMENT TABLET OTHER THAN THOSE SUPPLIED WITH YOUR UNIT.

Your unit purchase includes 4 **Water Treatment Tablets [16]**, which is sufficient for several years of use. To purchase additional chlorine tabs, please consult your nearest regional dealer/distributor.

- Resistance adjuster must be set to "10" to allow for accurate filling capacity.
- Do not overfill the tank beyond the maximum indicated level of 20 liters. Refer to the tank level decal on the tank.
- In areas where tap water quality is known to be poor, we recommend to use distilled water.

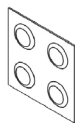

Water Treatment Tablets

- 1 : This setting keeps a portion of the water in reserve creating light resistance.
- 10 : This setting allows the maximum amount of water to reach the flywheel for.



Siphon

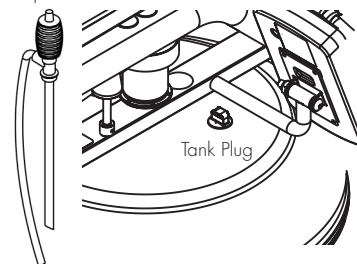

Tank Plug

# REMOVING / CHANGING TANK WATER

1. Set **Adjuster Knob [32]** to "1".
2. Row at least ten strokes to fill the storage reservoir as completely as possible. Remove the tank plug.
3. Insert rigid end of siphon into the tank, and flexible hose into a large bucket.
4. Drain tank using the siphon and then refill following directions for tank filling as described in the "Tank Filling" section of this manual (pg 33).  
*Note: Approximately 40% of tank water will remain. It is not possible to completely drain the tank without disassembly.*
5. Follow the Resistance Level Display guide in the Console set up page (pg 53) for level calibration.
  - The valve on top of the siphon must be closed to allow proper drainage.
  - Water treatment will preclude the need to change tank water if the treatment schedule is maintained. Additional **Water Treatment Tablets [32]** are required only when discoloration appears in the water.

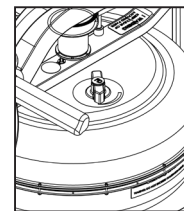
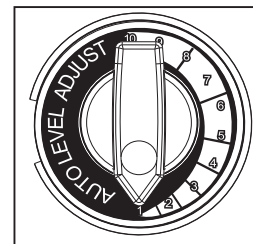

## LONG TERM WATER TREATMENT & BASIC OPERATION

Do not use any water treatment other than the tablets supplied with this unit. For replacement tablets, contact your local SPIRIT distributor. Water treatment schedules for your water rower will vary according to the fluid tanks exposure to sunlight, but expect 8-12 months near a bright, sunlit window and 2 years or more for a darker location. At the point of finding the water slightly cloudy, add a **Water Treatment Tablet [32]**.

*CAUTION: It is strongly recommended that a drop cloth be used under the fluid tank whenever the tank plug is opened for water treatment.*

# DETACHING THE ROWER BELT

1. To detach belt, simply pull beyond the range of the normal rowing stroke until the belt detaches from the belt bungee pulley.

*Note: You'll hear the Velcro separating just before the belt detaches.*

2. Unhook the **Bungee Shock Cord [19]** from the **Rear Brace [4]**. Then, push out the inner clip from the bungee hook. Pull the bungee through the inner clip until free. This will allow for the **Bungee Shock Cord [19]** to be threaded completely out of the **Main Frame [1]** and up to the belt bungee pulley where it will be re-attached once the rower belt is in the proper position.

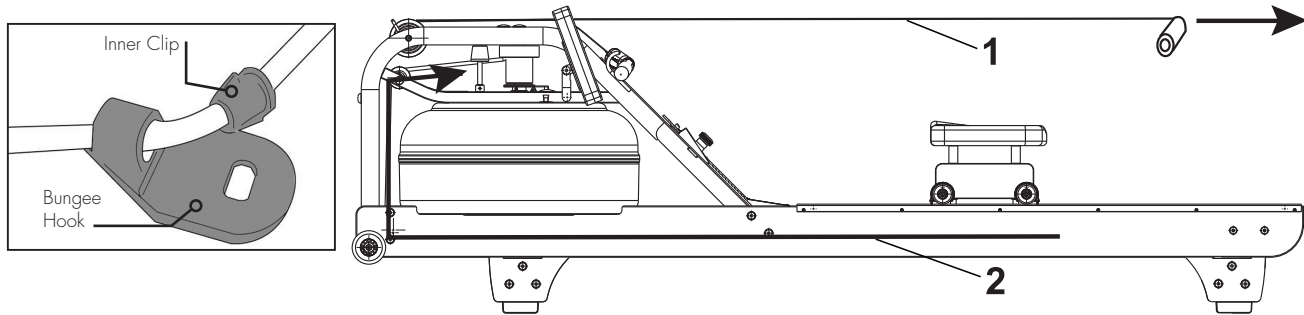

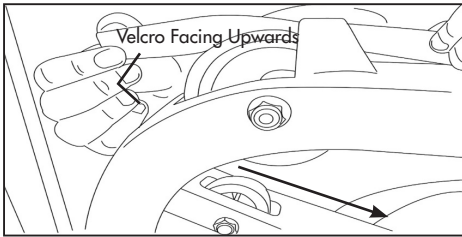

## REATTACHING THE ROWER BELT

### STEP 1

Begin reattaching the rower belt by threading around the rower belt pulley with the Velcro side facing upward as illustrated.

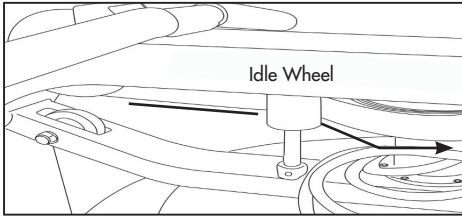

### STEP 2

Next, thread the belt around the idle wheel as shown. Once around the idle wheel, attach the rower belt to the belt/bungee pulley. There is an obvious "lip" at the attachment point.

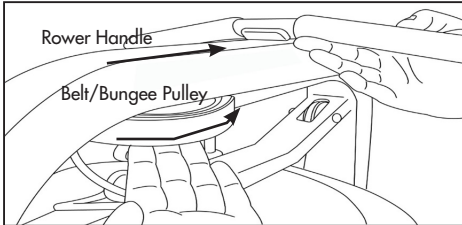

### STEP 3

Wind the rower belt onto the belt/bungee pulley until the rower handle is as it's furthest forward position.

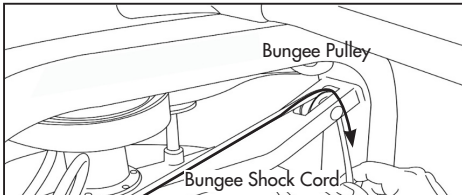

### STEP 4

Re-thread the **Bungee Shock Cord [19]** (on opposite side of the idle wheel) back through the bungee pulleys and tie off at the attachment point.

# REATTACHING THE ROWER BELT - CONTINUED

## STEP 5

Recoil tension will decrease over time as the **Bungee Shock Cord [19]** stretches. To increase recoil tension, simply push the inner clip out of the bungee hook from behind, pull the required amount of bungee through the inner clip and replace the inner clip into the bungee hook as shown below.

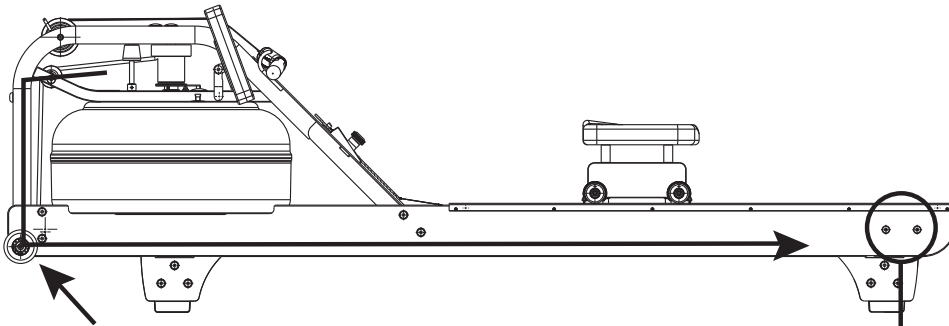

Hint: Before reattaching the inner clip/ bungee hook, tie a slip knot under slight tension at the lower bungee pulley. This will keep the bungee under tension while reassembling the bungee hook.

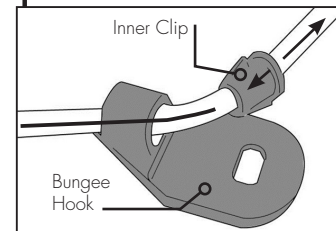

# ADJUSTING FOOTPLATES

The footplate slider accommodates most foot sizes, and is designed to keep your feet securely in place as you row. The feet should be positioned so that the foot strap covers the section of the foot that naturally bends as you row.

**TO ADJUST:** Lift the top of the footplate from the mounting peg and slide vertically between settings 1-6 to suit your foot length. Secure by hooking the footplate back on to the mounting peg and pushing down firmly to lock it into position. Place feet on the foot plates and tighten the foot straps to ensure your feet sit firmly against the heel captures.

Note: The heel capture should bend to allow your foot to pivot naturally as you row.

## WARNING

Never operate this rower without feet properly secured in foot straps, or without the sliding portion of the slider footplate locked into position!

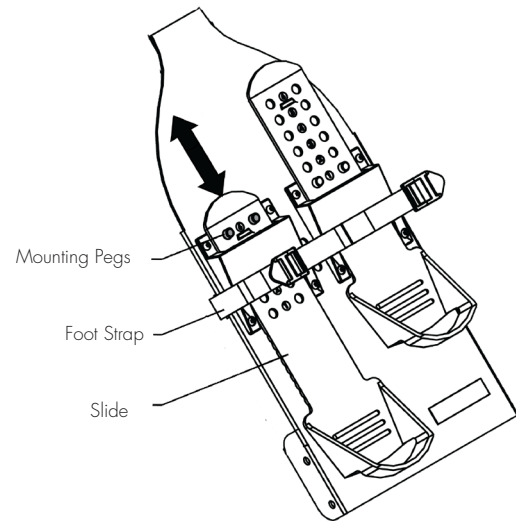

# ROWING FORM

1. Sit with straight legs and back, leaning forward slightly at the hips with arms out straight, hands level with the lower ribs. Pull back.
2. Legs and back straight, leaning slightly forward from the hips, arms out in front. Lean and slide forward. Note: Hands should now be around your knees, keeping legs straight.
3. Legs come forward, aiming to get the shins vertical. Back is still straight, and posture leaning slightly forward with arms still out front. Now drive hard, this is the CATCH.
4. Knees partially straightened so seat is now at mid-point of travel, back and arms still straight. Maintain the stroke.
5. Knees are nearly straight and back is still straight but now leaning slightly back from the hips. Arms straight. Now squeeze through.
6. Legs now fully extended. Back straight and leaning slightly back, now pull with the arms so they are close to the chest, forearms horizontal and elbows close in to the rib cage. This is the FINISH.

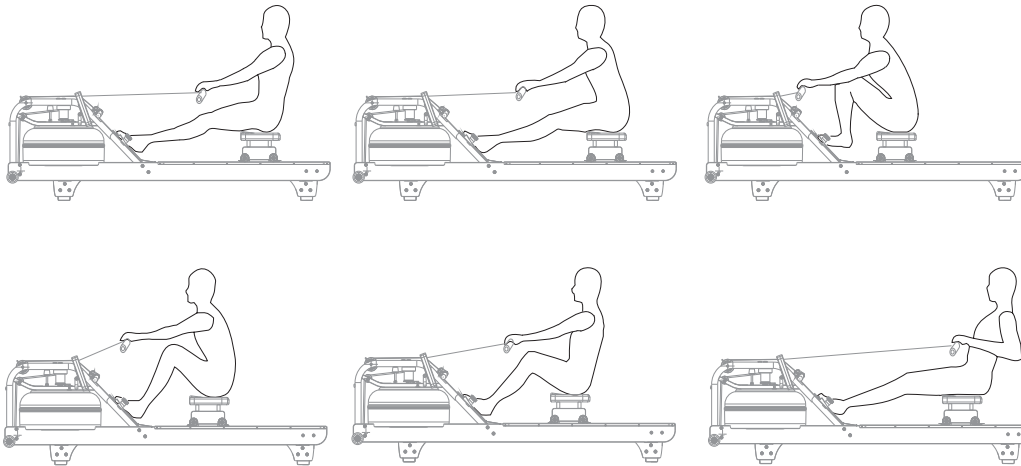



# *CRW900* CONSOLE OPERATION





# CONSOLE BUTTONS

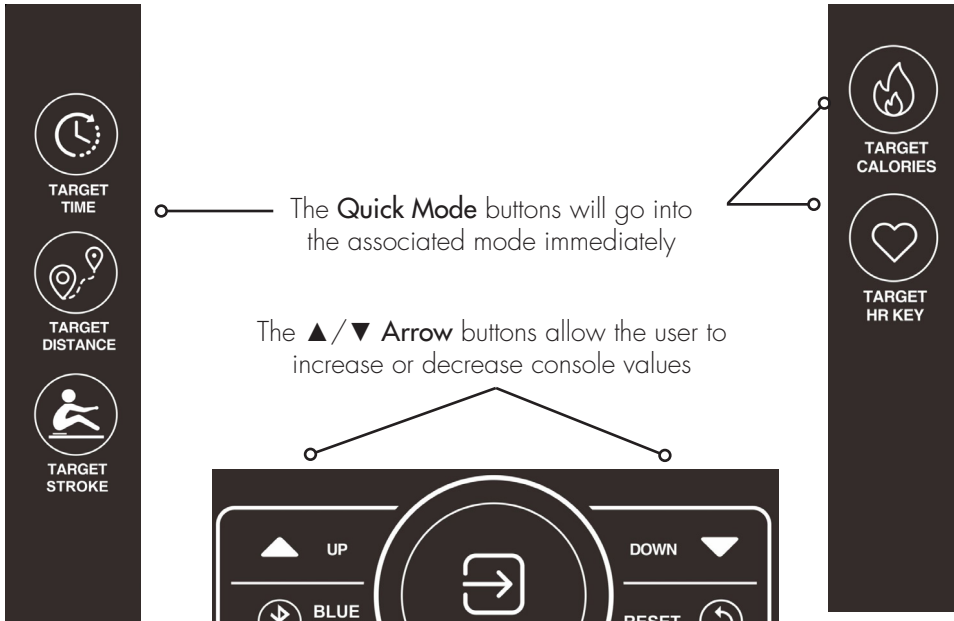

TARGET TIME



TARGET DISTANCE



TARGET STROKE



TARGET CALORIES



TARGET HR KEY

The **Quick Mode** buttons will go into the associated mode immediately

The **▲/▼ Arrow** buttons allow the user to increase or decrease console values

Use the **Bluetooth** button to upload the workout summary to the App. Work only in Stop Mode.

The **Enter** button is used to confirm a value as making adjustments to a mode

Use the **Reset** button to clear a value, to pause your workout, end your workout. Hold for 3 seconds for a Total Reset of all values (except Total Strokes).

# CONSOLE DISPLAY

Bluetooth Symbol - Displays when BLUETOOTH key is pressed

Resistance value displayed here.

When "TARGET TIME" is selected, time selection will be displayed here. Total elapsed time or time count down will be displayed during exercise."

Displays the time needed to row 500 meters according to current speed and average speed.

When "TARGET DISTANCE" is selected, distance selected will be displayed here. Overall distance will be displayed during workout.

When "TARGET CALORIES" is selected, calorie selection will be displayed here. Workout data for target calories will be displayed here during exercise.

SPM: Strokes Per Minute

Displays the power consumption during training.

When "TARGET STROKE" is selected, stroke selection will be displayed here. Overall stroke count will be displayed here during exercise."

Displays total accumulative stroke count.

Heart Rate Value will be displayed here.

When "TARGET HR" is selected, heart rate value (65%, 85%, and MAX) will be displayed here during exercise.

## TARGET TIME, DISTANCE, CALORIES MODE

The target panels will show Time, Distance, Calories and Strokes depending on operating mode. When the target  symbol is displayed, it means that target mode is operating in that particular value.

The TIME will alternate showing the remaining or elapsed time.

The DISTANCE will count or countdown in meters.

The CALORIES will count or countdown the number of calories burned during workout.

The STROKES will count or countdown the number of strokes during workout.

The TOTAL STROKES show the total number of strokes during workout.



## TIME - 500M / AVERAGE DISPLAY

The TIME/500m is time per 500 meters.

The AVERAGE is average time of several TIME/500m work out.





## SPM / WATTS DISPLAY

SPM and Watts will be displayed during all modes. SPM refers to Strokes per Minute. The WATTS will show the amount of work produced in a particular time during workout.



## HEART RATE DISPLAY

This panel will show every user's heart rate information. When console detects a signal from a wireless monitor, the BPM (beats-per-minute) will show in the large three-digit field and the heart icon will flash. However, if no signal is detected, three dashes "---" will display to indicate no heart rate detected.

While in TARGET HEART RATE mode, the console helps the user maintain in a BPM range to build cardiovascular endurance. The target value range will post next to the 65%, 85% and Max HR banners. The ▼ or ▲ symbol will flash to indicate that an increase or decrease of workout speed is needed to reach the desired range. When the user's heart rate is in the target range, the   icons will light.

To detect heart rate, the heart rate receiver must be installed and a heart rate chest strap (not included) must be used.

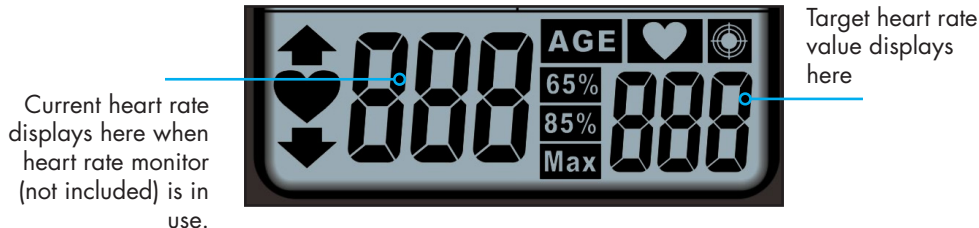

## **CONSOLE SETUP**

### **BATTERY INSTALLATION**

The console operates on 4 AA batteries. The battery compartment is on the back side of the console. Please dispose of batteries properly after use.

## **CONSOLE MODES**

### **SLEEP MODE**

After 60 seconds of inactivity, the console will switch into the power-saving "Sleep Mode". The display will switch off. Rotating the pedals or pressing any button on the console will launch the "Ready Mode".

### **READY MODE**

The "Ready Mode" informs the user that the console is powered on and ready to enter into any mode. After a period of 60 seconds of inactivity the console will switch into the "Sleep Mode".

### **PAUSE MODE**

The console will automatically enter "Pause Mode" if there is no input. TIME, DISTANCE, CALORIES, STROKE, and TOTAL STROKES will continue to be displayed in "Pause Mode". The 7-segment display shows LEVEL. TIME/500m and TIME/500m AVERAGE will be shown alternately. After the 30-second period, the buzzer will buzz for 2 seconds to go into "Stop Mode". In "Pause Mode", user can press the **RESET** button to go into the STOP screen.

## **STOP MODE**

Press the **RESET** button to go into the "Stop Mode" while in the "Pause Mode", or if there is no input via the console for 30 seconds the console will automatically enter "Stop Mode". In "Stop Mode", the 7-segment display will show "STOP", TIME will show total time, DISTANCE will show total distance, CALORIES will show total calories burned, STROKES will show the number of strokes for the workout, TOTAL STROKES will show the total number of strokes, TIME/500m and TIME/500m AVERAGE will be shown alternately for one minute. If the heart rate monitor has been used, the "Stop Mode" will show heart rates at 85%, at 65%, and the max heart rate for 5 seconds each, alternately. If no heart rate monitor has been used, then no values will be displayed.

## **WORKOUT SUMMARY**



The console provides a brief workout summary after completed the workout. Data displayed includes: Total Time, Total Distance and Total Watts.

## **RESET PROCESS**

To reset all saved settings, press and hold **RESET** button for 3 seconds.

# CONSOLE PROGRAMS

## QUICK START

As strokes are detected, the console will immediately launch QUICK START. TIME, DISTANCE, CALORIES, SPM, WATTS, STROKES, TOTAL STROKES will begin counting. TIME/500m and TIME/500m AVERAGE will be alternately displayed every 5 seconds. The 7-segment display will show level according to VR adjustments. When there's heart rate input, the  icon will stay lit, and the  icon will flash. Current heart rates will be shown. In the absence of heart rate input, three dashes "---" will be shown continuously.

## TARGET TIME, DISTANCE, CALORIES, AND STROKES PROGRAMS

Target Time, Target Distance, Target Calories, and Target Strokes program allow the target goal of each value to be customized.

**Launch:** Press the desired **TARGET** button (TIME, DISTANCE, CALORIES, STROKES).

**Setup:** When operating a target program (after the console has been reset), user will enter the target value. Adjust the value by pressing **▲** or **▼** buttons, then pressing the **ENTER** button to confirm the setting. If no value has been entered, the console will use the last setting as the target value on each mode.

**Start:** Each mode display field will light up and begin to readout data as follows:

*For the TARGET TIME program, the time target will begin to count down.*

*For the TARGET DISTANCE program, the distance will begin to calculating.*

*For the TARGET CALORIES program, the calories will begin calculating.*

*For the TARGET STROKES program, the strokes will begin calculating.*

**End:** The mode will end when the target is achieved. Pressing the **RESET** button at any time will also end the target program. The workout summary will be shown after the target program has ended, or the **RESET** button has been pressed.



## TARGET HEART RATE PROGRAMS

The Target Heart Rate program allows the maximum beats per minute (BPM) target to be customized to maximize cardiovascular training. The Heart Rate program calculates the maximum heart rate value based on the user's age to optimize the training target between 65% and 85% of the calculated or theoretical maximum heart rate.

**Launch:** Press the **Target Heart Rate** button.

**Setup:** When operating a target program (after the console has been reset), the user enters their age. Adjust the value by pressing ▲ or ▼ buttons, then pressing the **ENTER** button to confirm.

**Start:** The display field will light up and begin to display heart rate and progress toward cardiovascular goal. When the user's heart rate is lower than 65% of the calculated maximum HR range, the 65% display will flash indicating minimum goal has not yet been achieved. When the user's heart rate is over 85% of the calculated maximum HR range, the 85% display will flash indicating heart rate is over the maximum goal.

**End:** The target program will end when the user stops pedaling. Pressing the **RESET** button at any time will also end the target program. The workout summary will be shown after the "Target Program" has ended, or the **RESET** button has been pressed.

## BLUETOOTH

The Bluetooth function will only connect when the console is in the "Stop Mode". When the console is in "Stop Mode", press the **BLUETOOTH** button. The Bluetooth symbol will flash on the display. Connect to the console through the Bluetooth function on your device. After a device has been paired, the workout summary will upload to the SPIRIT Fit App (requires download via app store).

# ENGINEERING MODE

Press **Reset** and **Enter** buttons for 2 seconds to enter Engineering Mode. The console will also beep for 1 second. DISTANCE banner will blink first. Press ▲ or ▼ button to select setting section. (Sound → ODO → Sound)

While in Engineering Mode if there is no activity for 30 seconds, the console will switch STANDBY Mode. Pressing the **Reset** button will exit the Engineering Mode. The console settings and ODO will not be reset using the "RESET Mode", however, removing the batteries will return the console to original factory settings and the ODO value will be zero.

## AUDIO ON/OFF

- Under Engineering Mode of the Audio ON/OFF setting. The SOUND sign will blink. Press **Enter** to get into.
- After pressing **Enter**, the console will display "ON" or "OFF"
  - If the audio is on, the "ON" sign will blink.
  - If the audio is off, the "OFF" sign will blink.
- Press **Enter** to confirm and the console will return to Engineering Mode.
- While in this setting if there is no activity for 30 seconds or pressing **Reset**, the console will switch STANDBY Mode.

## ODO

The "ODO" feature displays the total time usage for your machine as H : M : S (hours, minutes, and seconds). Once the time odometer reaches the 2-hour mark, the odometer will begin to display the time in 1-hour increments. For example, "3H" would indicate 3 hours of total usage.

- When cycling through options in "Engineering Mode", press enter when "ODO" is blinking on the display.
- When the total exercise time exceeds 1:59:59, the LCD will display the numerical hour number next to an "H" (hours).
- To exit, press the ▼ or ▲ button to switch between other Engineering modes.
- While in this setting if there is no activity for 30 seconds, the console will enter STANDBY Mode. Pressing the **Reset** button twice will exit the Engineering Mode.

# GENERAL MAINTENANCE

A regular preventative maintenance schedule with your fitness equipment ensures that products are working at an optimal condition without affecting the your exercise experience. To assist in the maintenance regimen, it is recommended to break service into daily, weekly, & monthly activities.

Details on each activity can be found in the "Maintenance" section of this document (see pages 33 -38).

All preventive maintenance activities must be performed on a regular basis. Performing routine preventive maintenance actions can aid in providing safe, trouble-free operation of all SPIRIT equipment. SPIRIT is not responsible for performing regular inspection and maintenance for your machines. Be sure to train all necessary personnel in equipment inspection and maintenance actions, in addition to proper accident reporting and record keeping.

Item	Time Frame	Instructions	Notes
Seat and Seat Rails	Weekly	Wipe down seat rails with lint free cloth	
Frame	Weekly	Wipe down frame with lint free cloth	
Tank and Water Treatment	12m to 2years	Follow instructions as specified in the <b>Water Treatment Procedure</b> section of the manual [pg 33]	
Bungee Cord	Check every hundred hours for correct tension and for signs of wear.	The bungee cord should last for many years. If a bungee cord change is required, please contact your local service representative for further details.	
Rowing Belt	Check every hundred hours for correct tension and for signs of wear.	The rowing belt should provide many years of trouble free use. If a rowing belt change is required, please contact your local service representative for further details.	

# TROUBLESHOOTING

Issue	Possible Cause	Instructions
Water changes color or becomes cloudy	Rower is in direct sunlight or has not had water treatment Local tap water is of poor quality	Change rower location to reduce direct exposure to sunlight. Add water treatment or change tank water as directed in the <b>Water Treatment Section [pg 33]</b> of this manual. Consider using distilled water to refill tank.
Rower belt slipping off belt/ bungee pulley	Bungee not under enough tension Recoil not strong enough	Tighten bungee cord following the instructions in <b>Reattaching the Rower Belt [pg 36]</b> section of this manual.
Inconsistent readings on the console for 500meter split time and SPM (strokes per minute)	Sensor gap issue Faulty sensor Sensor has moved out of position Wiring harness issue	Use the back cover of the computer as a "gap tool" to check the gap between sensor head and magnetic ring, or see if the sensor head has moved out of position. Please contact your nearest SPIRIT customer service center for details.
The console does not illuminate after battery installation	Batteries installed incorrectly or need replacing	Check to see if the batteries are installed in the correct position. Reinstall or replace as needed. If the LCD screen fails to illuminate, try rotating the batteries slightly in the computer. If this fails, contact your local service center.
The console screen illuminates, but does not register when rowing	Loose or failed connection Sensor gap too wide	Check that the computer lead is connected properly. If it is connected then contact your local service center. Check sensor gap.

- Please contact your nearest SPIRIT customer service if any assistance is required.

# TROUBLESHOOTING CONTINUED

Issue	Possible Cause	Instructions
Trouble with resistance	VR Setting	<ol style="list-style-type: none"><li>1. Hold down ENTER+UP+DOWN buttons for 2 seconds. After entering VR settings mode, the buzzer will buzz for 1 second.</li><li>2. The 7-segment display will show "VR". The time window will show "L".</li><li>3. Adjust VR for the first increment, then press the ENTER KEY to confirm.</li><li>4. The time window will show "H". Adjust VR for the highest increment, then press ENTER button to confirm.</li><li>5. After setting the highest and lowest VR, the console then completes the VR settings and enters standby mode.</li><li>6. Configured VR range will automatically be divided into 10 even increments.</li></ol>

- Please contact your nearest SPIRIT customer service if any assistance is required.



# Main Frame Assembly

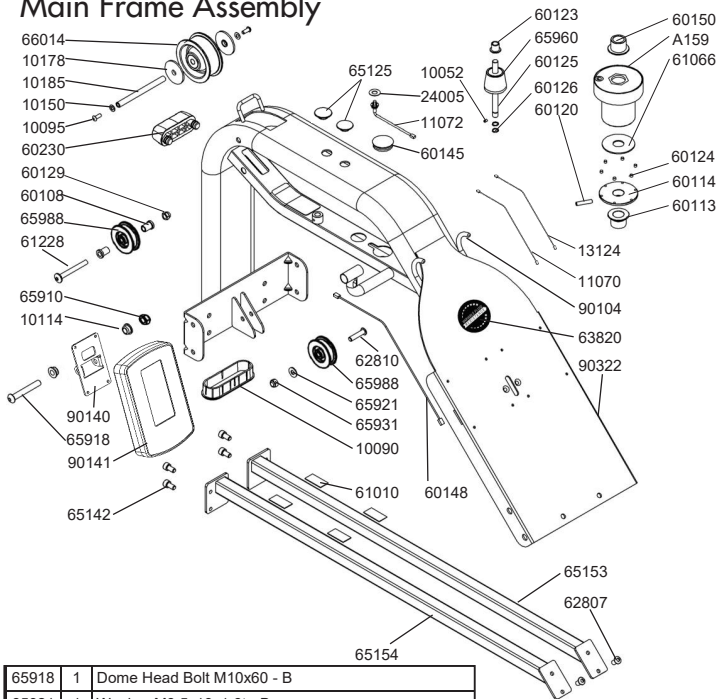

65918	1	Dome Head Bolt M10x60 - B
65921	1	Washer M8.5x19x1.6t - B
65931	1	Nyloc Nut M8 - B
65960	1	Idle Wheel & Bearing 6000ZZ x 2 <b>#60112</b>
65988	2	Bungee Pulley & Bearing & Spacer x2
66014	1	Belt Pulley with 6000ZZ Bearings Complete
90104	2	Rubber Hook Cover 8mm x 50mm
90140	1	CY Console Support
90141	1	CY Console
90322	1	Upper Frame - SPIRIT
A159	1	Bel/ Bungee Pulley Complete with Bungee Assembly

PN	Qty	Description
10052	1	Grub Screws M4x6 - B
10090	1	End Cap 118x40mm
10095	2	Dome Head Bolt M6x10 - B
10114	2	Computer Mount Plastic Bushing 20x16x13x10
10150	2	Washer M6x13x1t - B
10178	2	Plastic Spacer D46x4T for Belt Pulley
10185	1	Axle Shaft 10mm for Belt Pulley
11070	1	Sensor Connecting Cable 300mm
11072	1	Sensor 100mm
13124	1	Level Wiring 300mm
24005	1	Washer M11x22x1t SUS
60108	2	Bungee Pulley Spacer 8mm
60113	1	Main Shaft Oil Bushing - Lower 38x20x22
60114	1	Magnet Ring & 6 x Magnet <b>#60124</b>
60120	1	Roll Pin M6x30
60123	1	Idle Shaft Upper Frame Mount 10mm
60125	1	Idler Pulley Shaft 10x107mm
60126	2	C Clip 10mm
60129	1	Nut Dome Head M8 - B
60145	1	Frame Plug 38.1mm
60148	1	Heart Rate Lead- 400mm
60150	1	Main Shaft Nylon Bushing - Upper
60230	1	Rubber Bumper
61010	4	Tank Bonding Strip 3M-VHB 20x40x1mm
61066	1	Plastic Washer M5920.1x2T
61228	1	Dome Head Bolt M8x65 - B
62807	2	Dome Head Bolt M8x15 - B
62810	1	Dome Head Bolt M8x35 - B
63820	1	Round Decal - VFR
65125	2	Rubber End Cap - Main Frame
65142	4	Hex Head Bolt M8x15 - B
65153	1	Tank Strut Bracket - APPRO - Left
65154	1	Tank Strut Bracket - APPRO - Right
65910	1	Nyloc Nut M10 - B

## A1078 - 10 Level Tank Complete Assembly

Not Sold Separately

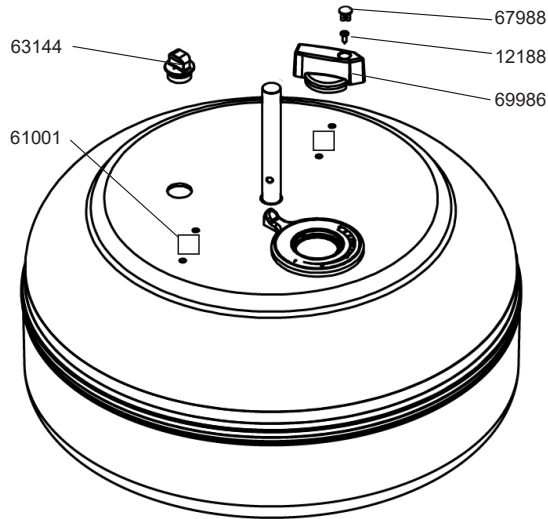

FDF PN	Qty	Description
12188	1	Dome Head Bolt M4x15 SUS
61001	2	Tank Bonding Strip 3M-VHB 40x40x1mm
63144	1	Tank Plug for HS Tank
67988	1	Knob Cap
69986	1	Adjuster Knob

## Sliding Footplate Assembly

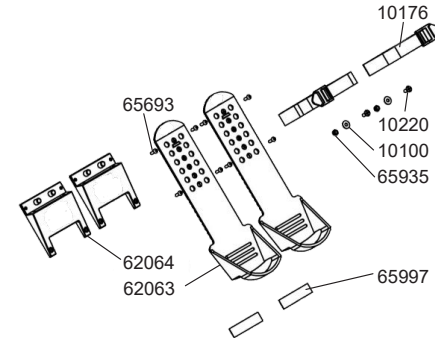

10100	2	Washer M6x16x1 - B
10176	2	Foot Strap & Buckle
10220	2	Counter Sunk Bolt M6x20 - B
62063	2	Footplate Slider with Velcro #65997
62064	2	Footplate Slider Base 120x111x22.8
65693	8	Dome Head Bolt M5x15 - B
65935	2	Nylock Nut M6 - B
65997	2	Velcro For Sliding Footplate



## A386 Plastic Handle Complete

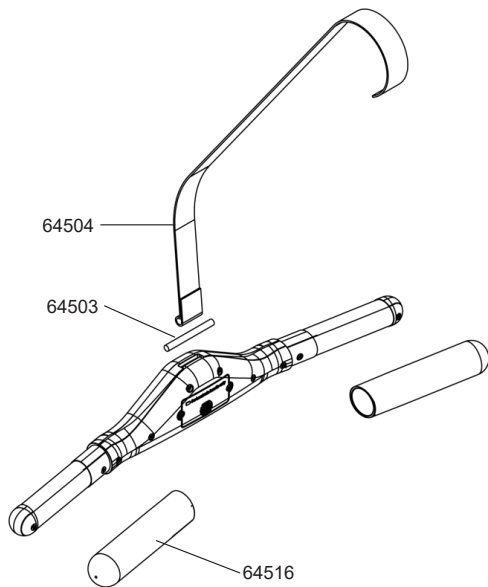

64503	1	Belt Bush
64504	1	Belt
64516	2	Handle Grip

## A159 Belt Bungee Pulley Complete

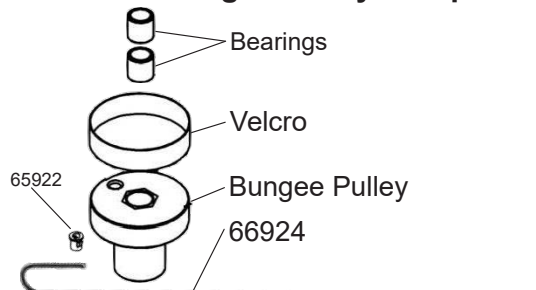

60900	1	Belt Bungee Pulley Complete & Velcro & One Way Bearings #90136
66924	1	Bungee 8mm x 2230 & Inner Clip #65922

## A385 Seat Assembly Complete

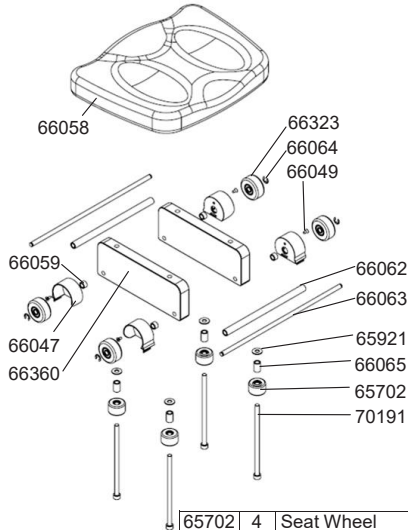

65702	4	Seat Wheel
65921	4	Washer 8.5x19x1.6t - B
66047	2	Brush Cover - Left & Right
66049	4	Counter Sunk Bolt 5/32
66058	1	Seat LS-E28 for Wooden Rail
66059	4	Spacer 12.7x8x8.5
66062	2	Spacer 12x8x209
66063	2	Axle Shaft 8mm
66064	4	D7 Eclip
66065	4	Spacer 12.7x8x19.5
66323	4	Seat Wheel 98A
66360	2	Seat Frame - Black
70191	4	Hex Head Bolt M8x130 - B

## A387 Side Rail Assembly L/R

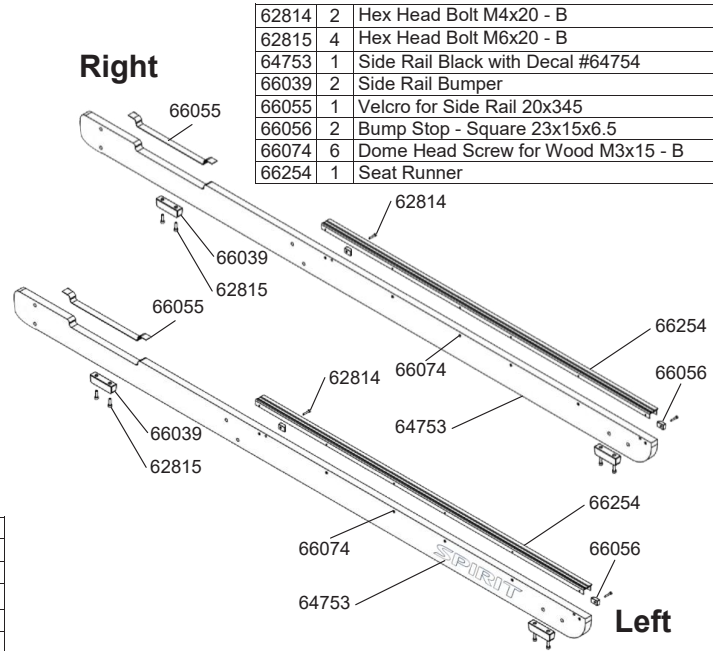

62814	2	Hex Head Bolt M4x20 - B
62815	4	Hex Head Bolt M6x20 - B
64753	1	Side Rail Black with Decal #64754
66039	2	Side Rail Bumper
66055	1	Velcro for Side Rail 20x345
66056	2	Bump Stop - Square 23x15x6.5
66074	6	Dome Head Screw for Wood M3x15 - B
66254	1	Seat Runner

62814	2	Hex Head Bolt M4x20 - B
62815	4	Hex Head Bolt M6x20 - B
64753	1	Side Rail Black with Decal #64754
66039	2	Side Rail Bumper
66055	1	Velcro for Side Rail 20x345
66056	2	Bump Stop - Square 23x15x6.5
66074	6	Dome Head Screw for Wood M3x15 - B
66254	1	Seat Runner

## EVK - Elevate Kit Assembly

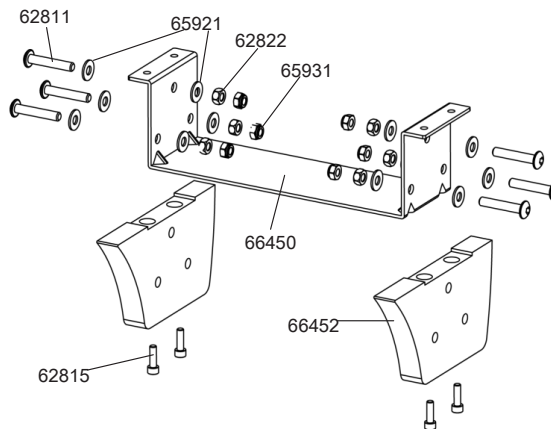
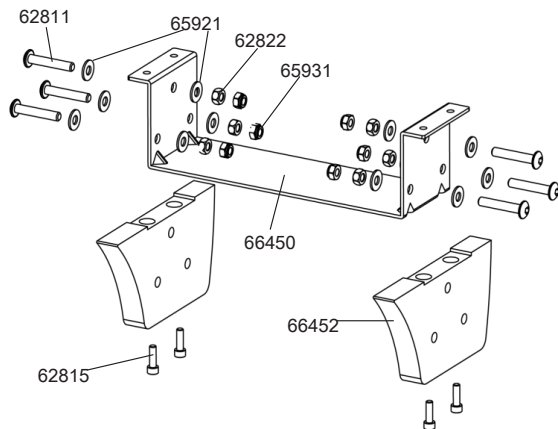

62811	12	Dome Head Bolt M8x45 - B
62815	8	Hex Head Bolt M6x20 - B
62822	12	Nut M8 - B
65921	24	Washer M8.5x19x1.6t - B
65931	12	Nyloc Nut M8 - B
66450	2	U Bracket
66452	4	Elevate Leg with Bushing

## **CRW900 WATER ROWER WARRANTY** EFFECTIVE MAY 7, 2019

Spirit Fitness warrants all its fitness rower parts for a period of time listed below from the date of retail sale, as determined by sale receipt, or in the absence of a sales receipt eighteen (18) months from the original factory shipping date. Spirit Fitness' responsibilities include providing new or remanufactured parts, at Spirit Fitness' option, and technical support to our independent dealers and servicing organizations. In the absence of a dealer or service organization, these warranties will be administered by Spirit Fitness directly to a consumer. The warranty period applies to the components as follows:

<b>Warranty</b>	<b>Frame</b>	<b>Parts</b>	<b>Tank &amp; Seals</b>	<b>Wearable Parts</b>	<b>Labor</b>
Commercial	10 Years	2 Years	3 Years	1 Year	1 Year
Residential	Lifetime	5 Years	5 Years	5 Years	2 Years

### **NORMAL RESPONSIBILITIES OF THE CONSUMER**

The consumer is responsible for the items listed below:

- Proper use of the fitness equipment in accordance with the instructions provided in this manual.
- Proper installation in accordance with instructions provided with the fitness equipment and with all local electric codes.
- Proper connection to a grounded power supply of sufficient voltage, replacement of blown fuses, repair of loose connections or defects in house or facility wiring.
- Expenses for making the fitness equipment accessible for servicing, including any item that was not part of the fitness equipment at the time it was shipped from the factory.
- Damages to the fitness equipment finish during shipping, installation or following installation.
- Routine maintenance of this unit as specified in this manual.

## **EXCLUSIONS**

This warranty does not cover the following:

1. CONSEQUENTIAL, COLLATERAL, OR INCIDENTAL DAMAGES SUCH AS PROPERTY DAMAGE AND INCIDENTAL EXPENSES RESULTING FROM ANY BREACH OF THIS WRITTEN OR ANY IMPLIED WARRANTY.  
Note: Some states do not allow the exclusion or limitation of incidental or consequential damages, so this limitation or exclusion may not apply to you.
2. Service call reimbursement to the consumer. Service call reimbursement to the dealer that does not involve malfunction or defects in workmanship or material, for units that are beyond the warranty period, for units that are beyond the service call reimbursement period, or for fitness equipment not requiring component replacement.
3. Damages caused by services performed by persons other than authorized Spirit Fitness service companies; use of parts other than original Spirit Fitness parts; or external causes such as corrosion, discoloration of paint or plastic, alterations, modifications, abuse, misuse, accident, improper maintenance, inadequate power supply, or acts of God.
4. Products with original serial numbers that have been removed or altered.
5. Products that have been: sold, transferred, bartered, or given to a third party.
6. Spirit Fitness reserves the right to request proof of purchase if no warranty record exists for the product.
7. THIS WARRANTY IS EXPRESSLY IN LIEU OF ALL OTHER WARRANTIES EXPRESSED OR IMPLIED, INCLUDING THE WARRANTIES OF MERCHANTABILITY AND/OR FITNESS FOR A PARTICULAR PURPOSE.
8. Product used in prisons and correctional facilities

## **CUSTOMER SUPPORT**

If any items need replacement contact the Spirit Fitness Customer Support Department at (870) 935-1107 (Local) or (800) 258-8511. For international customers, please contact your local distributor.

## SERVICE

- Keep your bill of sale. Twelve (12) months from the date on the bill of sale or eighteen (18) months from the date of factory shipping as determined by the serial number establishes the labor warranty period should service be required. If service is performed, it is in your best interest to obtain and keep all receipts. This written warranty gives you specific legal rights. You may also have other rights that vary from state to state within the United States. Service under this warranty must be obtained by following these steps, in order:
- Contact your selling authorized Spirit Fitness dealer. OR
- Contact your local authorized Spirit Fitness service organization.
- If there is a question as to where to obtain service, contact our service department at (870) 935-1107. For international customers, please contact your local distributor.
- Spirit Fitness' obligation under this warranty is limited to repairing or replacing, at Spirit Fitness' option, the product through one of our authorized service centers. All repairs must be preauthorized by Spirit Fitness. If the product is shipped to a service center freight charges to and from the service center will be the customer's responsibility. For replacement parts shipped while the product is under warranty, the customer will be responsible for shipping and handling charges. For in-home service, the customer will be responsible for a trip charge. There will be an additional trip charge if the customer is located over 100 miles from the nearest service center.
- The owner is responsible for adequate packaging upon return to Spirit Fitness. Spirit Fitness is not responsible for damages in shipping. Make all freight damage claims with the appropriate freight carrier. **DO NOT SHIP ANY UNIT TO OUR FACTORY WITHOUT A RETURN AUTHORIZATION NUMBER.** All units arriving without a return authorization number will be refused.
- For any further information, or to contact our service department by mail, send your correspondence to:

Spirit Fitness  
P.O. Box 2037  
Jonesboro, AR 72402-2037

*Product features or specifications as described or illustrated are subject to change without notice. All warranties are made by Spirit Manufacturing, Inc. This warranty applies only in the 48 contiguous United States. NOTE: This does not apply to Alaska or Hawaii.*

## **MANUFACTURER**

### **Dyaco Commercial & Medical North America**

18303 Bothell Everett Hwy.  
Suite 210  
Bothell, WA 98012  
TEL: +1-425-659-2401 (Local)  
TOLL-FREE: +1-866-463-2662  
EMAIL: Questions@spiritfitness.com

## **INTERNATIONAL OFFICES**

### **Taipei HQ Office**

12F, No.111, Songjiang  
Rd. Taipei City, Taiwan, 10486  
TEL: +886-2-2515-2288  
FAX: +886-2-2515-9963  
EMAIL: info@dyaco.com

### **Dyaco Japan**

Ryogoku ST Bldg. 7F 2-17-17  
Ryogoku Sumida Tokyo 130-0026, Japan  
TEL: +81 3-5669-0405  
FAX: +81 3-5669-0406  
EMAIL: info@dyacojapan.co.jp

### **Dyaco Shanghai**

Room 210, No.350  
Hengren Road  
Yangpu District  
Shanghai, China 200438  
TEL: 86-21-65068300  
FAX: 86-21-65068150

### **Dyaco UK Ltd**

Fairbourne Drive  
Atterbury  
Milton Keynes  
MK10 9RG UK  
TEL: +44-0-800 029 3865  
EMAIL: sales@dyaco.co.uk

### **Dyaco Germany**

Technologiepark Bergisch-Gladbach  
Haus 56  
Friedrich-Ebert-Straße 75  
51429 Bergisch Gladbach  
TEL: +49-0-2204 844 340  
FAX: + 49-0-2204 844 333  
EMAIL: info@dyaco.de

### **Dyaco Canada**

5955 Don Murie Street  
Niagara Falls, ON  
L2G 0A9  
Canada  
TEL: +1 888-707-1880  
FAX: +1 905-353-8968  
EMAIL: sales@dyaco.ca













800.258.4555  
Questions@spiritfitness.com  
www.spiritfitness.com



Spirit Fitness  
3000 Nestle Road  
Jonesboro, AR 72401



CRW900 Owners Manual  
© 2019 All Rights Reserved  
Revision 2: 06.20.2019