

Scale: 4:1

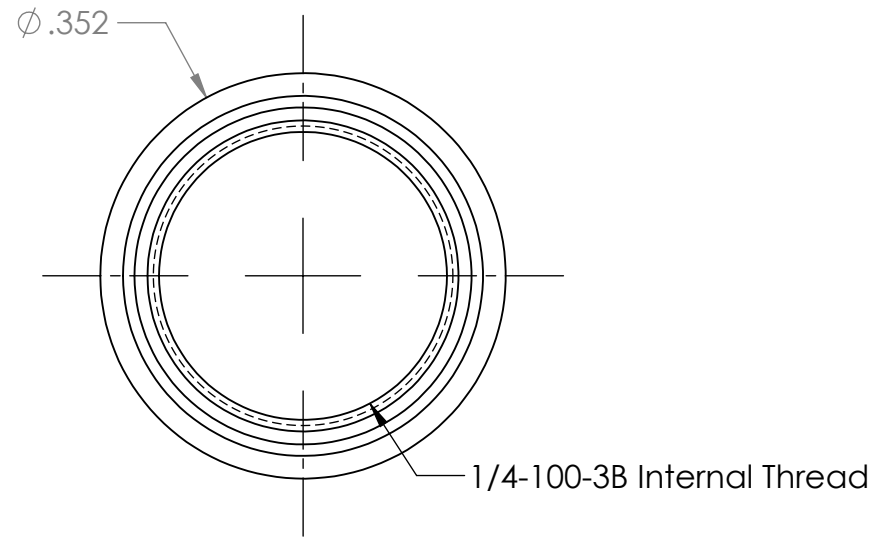
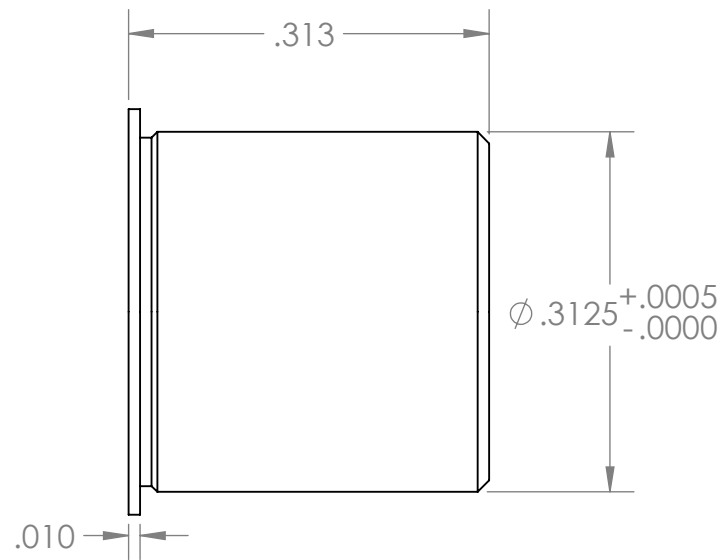

**PROPRIETARY AND CONFIDENTIAL**  
 THE INFORMATION CONTAINED IN THIS DRAWING IS THE SOLE PROPERTY OF KOZAK MICRO ADJUSTERS. ANY REPRODUCTION IN PART OR AS A WHOLE WITHOUT THE WRITTEN PERMISSION OF KOZAK MICRO ADJUSTERS IS PROHIBITED.

		UNLESS OTHERWISE SPECIFIED:		NAME	DATE	Kozak Micro Adjusters							
		DIMENSIONS ARE IN INCHES TOLERANCES: FRACTIONAL $\pm 1/64$ ANGULAR: MACH $\pm$ BEND $\pm$ TWO PLACE DECIMAL $\pm .01$ THREE PLACE DECIMAL $\pm .005$		DRAWN	D.K.			10.09.12					
		INTERPRET GEOMETRIC TOLERANCING PER:		CHECKED	D.K.	10.24.12	TITLE: 1/4-100 x 0.313" Adj. Bushing						
		MATERIAL 303 Stainless Steel		ENG APPR.	D.K.	10.26.12							
		FINISH		MFG APPR.	G.K.	11.12.12							
NEXT ASSY	USED ON			Q.A.			<table border="1"> <tr> <td>SIZE</td> <td>DWG. NO.</td> <td>REV</td> </tr> <tr> <td><b>A</b></td> <td>TB250-100-313-S</td> <td><b>A</b></td> </tr> </table>	SIZE	DWG. NO.	REV	<b>A</b>	TB250-100-313-S	<b>A</b>
SIZE	DWG. NO.	REV											
<b>A</b>	TB250-100-313-S	<b>A</b>											
APPLICATION		DO NOT SCALE DRAWING		COMMENTS:									
				SCALE: 8:1	WEIGHT:	SHEET 1 OF 1							

5

4

3

2

1