

Scale: 4:1

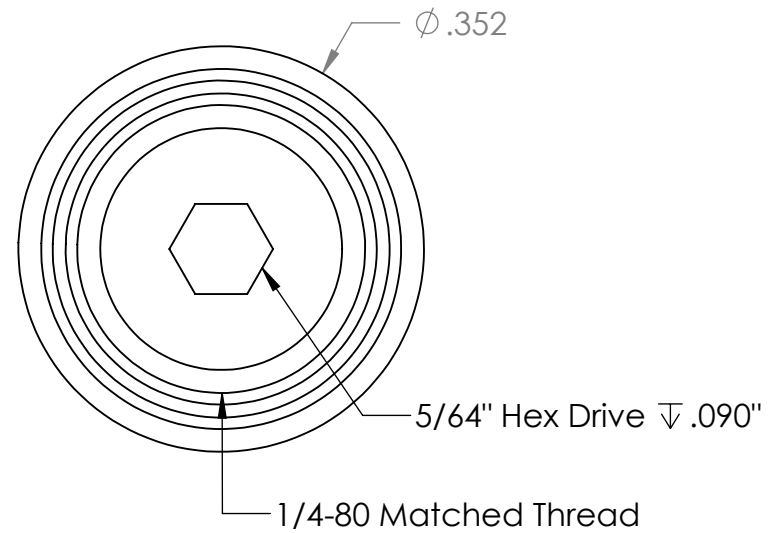
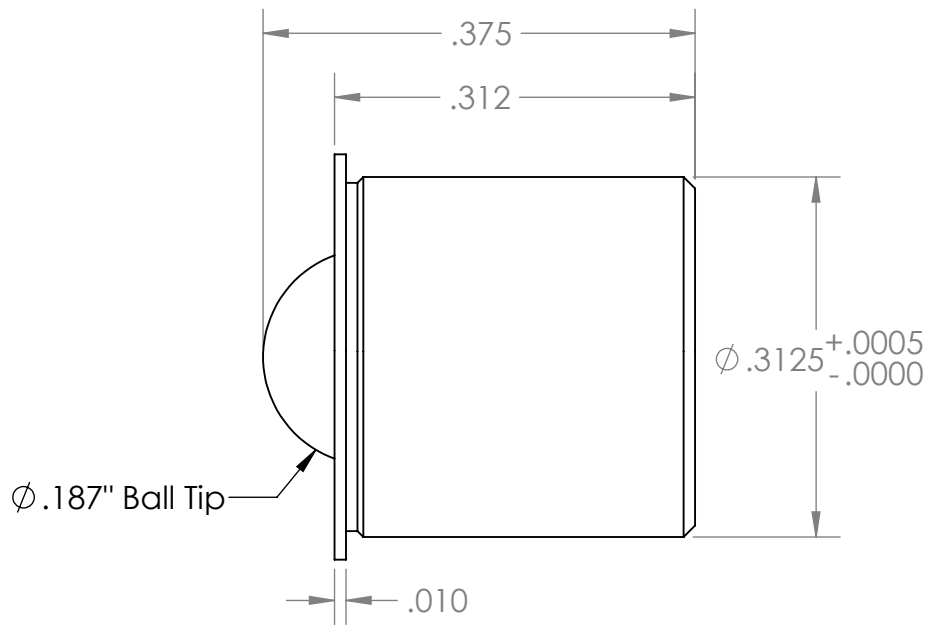

**PROPRIETARY AND CONFIDENTIAL**  
 THE INFORMATION CONTAINED IN THIS DRAWING IS THE SOLE PROPERTY OF KOZAK MICRO ADJUSTERS. ANY REPRODUCTION IN PART OR AS A WHOLE WITHOUT THE WRITTEN PERMISSION OF KOZAK MICRO ADJUSTERS IS PROHIBITED.

		UNLESS OTHERWISE SPECIFIED:	NAME	DATE	Kozak Micro Adjusters	
		DIMENSIONS ARE IN INCHES TOLERANCES: FRACTIONAL $\pm 1/64$ ANGULAR: MACH $\pm$ BEND $\pm$ TWO PLACE DECIMAL $\pm .01$ THREE PLACE DECIMAL $\pm .005$	DRAWN	D.K.		
		INTERPRET GEOMETRIC TOLERANCING PER:	CHECKED	D.K.	10.24.12	TITLE: 1/4-80 x 0.375" Adj. Screw & 0.312" Adj. Bushing
		MATERIAL 303 SS & 360 Brass	ENG APPR.	D.K.	10.26.12	
		FINISH	MFG APPR.	G.K.	11.12.12	
NEXT ASSY	USED ON		Q.A.			SIZE <b>A</b>
APPLICATION		DO NOT SCALE DRAWING	COMMENTS:			DWG. NO. TSB250-80-375/312-AA
						REV <b>A</b>
						SCALE: 6:1
						WEIGHT:
						SHEET 1 OF 1

5

4

3

2

1