

Scale: 2:1

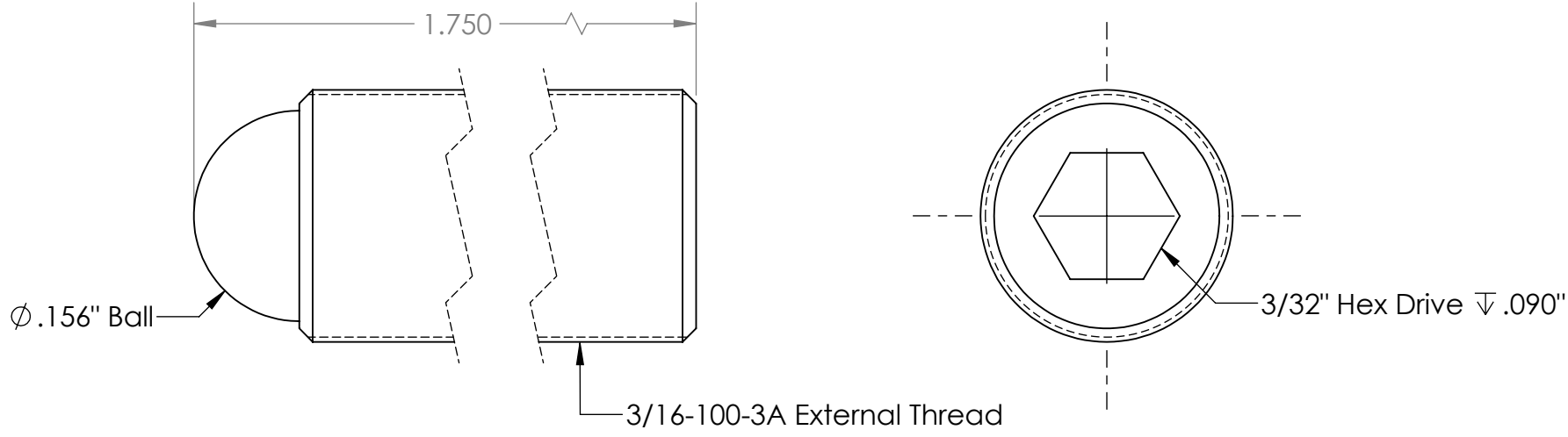

PROPRIETARY AND CONFIDENTIAL
 THE INFORMATION CONTAINED IN THIS DRAWING IS THE SOLE PROPERTY OF KOZAK MICRO ADJUSTERS. ANY REPRODUCTION IN PART OR AS A WHOLE WITHOUT THE WRITTEN PERMISSION OF KOZAK MICRO ADJUSTERS IS PROHIBITED.

| | | | | | |
|-------------|---------|--------------------------------------|-----------|------|----------|
| | | UNLESS OTHERWISE SPECIFIED: | | NAME | DATE |
| | | DIMENSIONS ARE IN INCHES | DRAWN | D.K. | 10.09.12 |
| | | TOLERANCES: | CHECKED | D.K. | 10.24.12 |
| | | FRACTIONAL ±1/64 | ENG APPR. | D.K. | 10.26.12 |
| | | ANGULAR: MACH ± BEND ± | MFG APPR. | G.K. | 11.12.12 |
| | | TWO PLACE DECIMAL ±.01 | Q.A. | | |
| | | THREE PLACE DECIMAL ±.005 | COMMENTS: | | |
| | | INTERPRET GEOMETRIC TOLERANCING PER: | | | |
| | | MATERIAL | | | |
| | | 303 Stainless Steel | | | |
| NEXT ASSY | USED ON | FINISH | | | |
| APPLICATION | | DO NOT SCALE DRAWING | | | |

| | | |
|------------------------------|-------------------|--------------|
| Kozak Micro Adjusters | | |
| TITLE: | | |
| 3/16-100 x 1.750" Adj. Screw | | |
| SIZE | DWG. NO. | REV |
| A | TS187-100-1750-AA | A |
| SCALE: 8:1 | WEIGHT: | SHEET 1 OF 1 |