

Scale: 4:1

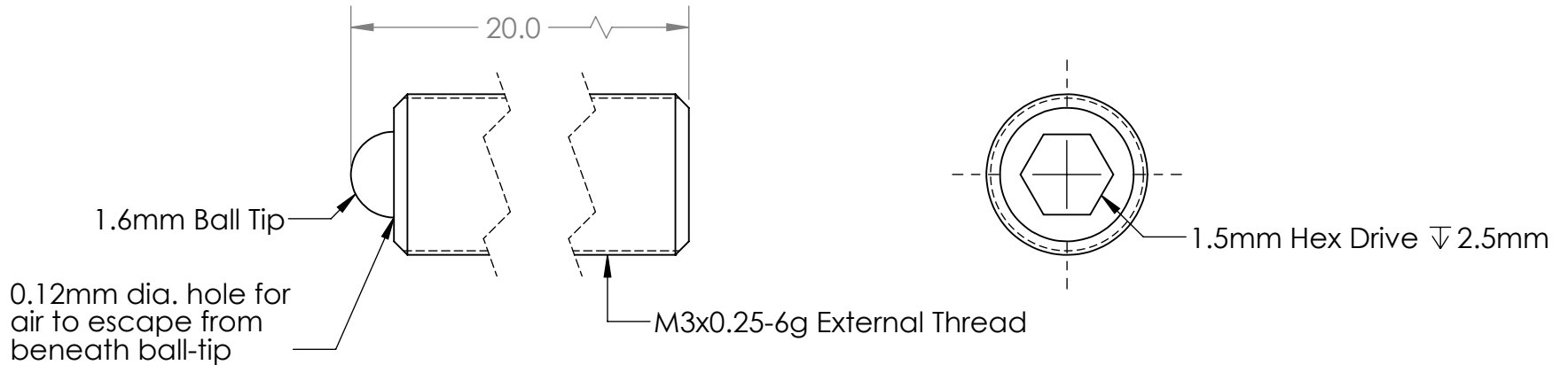

PROPRIETARY AND CONFIDENTIAL
 THE INFORMATION CONTAINED IN THIS DRAWING IS THE SOLE PROPERTY OF KOZAK MICRO ADJUSTERS. ANY REPRODUCTION IN PART OR AS A WHOLE WITHOUT THE WRITTEN PERMISSION OF KOZAK MICRO ADJUSTERS IS PROHIBITED.

		UNLESS OTHERWISE SPECIFIED:		NAME	DATE	Kozak Micro Adjusters		
		DIMENSIONS ARE IN MILLIMETERS	DRAWN	D.K.	10.09.12			
		TOLERANCES:	CHECKED	D.K.	10.24.12	SIZE DWG. NO. REV A TS3-25-20-HV A		
		FRACTIONAL \pm	ENG APPR.	D.K.	10.26.12			
		ANGULAR: MACH \pm BEND \pm	MFG APPR.	G.K.	11.12.12	COMMENTS:		
		ONE PLACE DECIMAL $\pm .1$	Q.A.					
		TWO PLACE DECIMAL $\pm .01$	COMMENTS:			NEXT ASSY USED ON		
		INTERPRET GEOMETRIC TOLERANCING PER:						
		MATERIAL				APPLICATION DO NOT SCALE DRAWING		
		304 Stainless Steel						
		FINISH				APPLICATION DO NOT SCALE DRAWING		