



**NEW 2024**

# ROCK TOP & ROCK SIDE

*Combining quality and elegance*

- **GELCOAT tank:** Excellent strength and long service life
- **Flow rate from 10m<sup>3</sup>/h to 22m<sup>3</sup>/h** (Rock Top)
- **Flow rate from 10m<sup>3</sup>/h to 31.8m<sup>3</sup>/h** (Rock Side)
- For pools from **60 to 185m<sup>3</sup>**
- Integrated meter
- Tank material: Laminated fiberglass
- Maximum operating pressure: **2.5 bar (36 PSI)**
- Maximum operating temperature: 40°C
- 6-way valve



**TANK WARRANTY**

**10  
YEARS**

**VALVE WARRANTY**

*(excluding seals - domes - pressure gauge)*

**3  
YEARS**

## HIGH-QUALITY FILTRATION

**Rock Top & Rock Side filters are high-quality filtration equipment** designed for efficient water purification in swimming pools.

**High-quality laminate construction:** The filters are made from high-quality materials, offering a robust laminated construction. This design ensures superior resistance to pressure, guaranteeing long-term durability, even in demanding environments.

**Simplified maintenance:** Their intelligent design allows effortless cleaning and replacement of filter elements, reducing downtime.

**Versatile compatibility:** These filters are compatible with a variety of filtration pumps, making them easy to integrate into existing filtration systems. This versatility makes them the right choice for a variety of configurations.



**TANK MATERIAL**  
Laminated fiberglass



**MAX FUNCTIONING PRESSURE**  
36 psi / 2.5 bar



**FILTER MEDIA GRANULOMETRY**  
0.5-0.8 mm



**MAXIMUM TEMPERATURE**  
40°C (104°F)



	TOP 500	TOP 650	TOP 750
References	PF-RCK500T	PF-RCK650T	PF-RCK750T
Maximum flow (m³/h)	10	16.5	22
Filtration area (m²)	0.20	0.33	0.44
Addressable volume (m³ in approximately 6h)	60	95	125
Input/output connections	1.5" / 50mm		2.0" / 63mm
Diameter (mm)	500	650	750
Sand (kg) / Glass (kg)	88 / 70	158 / 125	260 / 210
Dimensions (AxBxC)	886 x 750 x 693	998 x 862 x 805	1159 x 1029 x 945
Dimensions (DxExF)	286 x 390 x 500	318 x 500 x 650	251 x 500 x 750
Warranty	Tank: 10 years / Valve: 3 years		

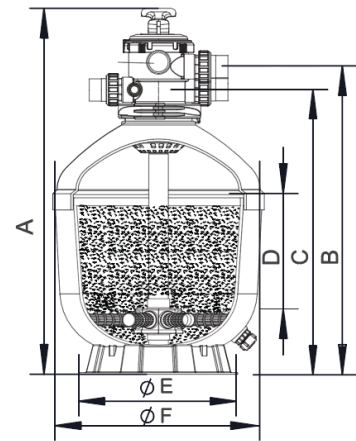

	SIDE 500	SIDE 650	SIDE 750	SIDE 900
References	PF-RCK500S	PF-RCK650S	PF-RCK750S	PF-RCK900S
Maximum flow (m³/h)	10	16.5	22.1	31.8
Filtration area (m²)	0.20	0.33	0.44	0.64
Addressable volume (m³ in approximately 6h)	60	95	125	185
Input/output connections	1.5" / 50mm		2.0" / 63mm	
Diameter (mm)	500	650	750	900
Sand (kg) / Glass (kg)	100 / 70	185 / 150	265 / 215	405 / 325
Dimensions (AxBxC)	424 x 487 x 845	472 x 535 x 943	517 x 603 x 1015	583 x 669 x 1165
Dimensions (DxExF)	360 x 516 x 390	380 x 666 x 390	440 x 770 x 500	480 x 920 x 780
Warranty	Tank: 10 years / Valve: 3 years			

