

BOMBAS SOPLANTES

1 HP - 2 HP - 3 HP - 4 HP



Descripción

Los electroagitadores de aire son utilizados para la disolución de productos en tanques de abono. Puede actuar sobre diferentes tanques simultánea o alternativamente.

Características

- Dispone de un relé de protección térmica que interrumpe el funcionamiento en caso de sobrecalentamiento.

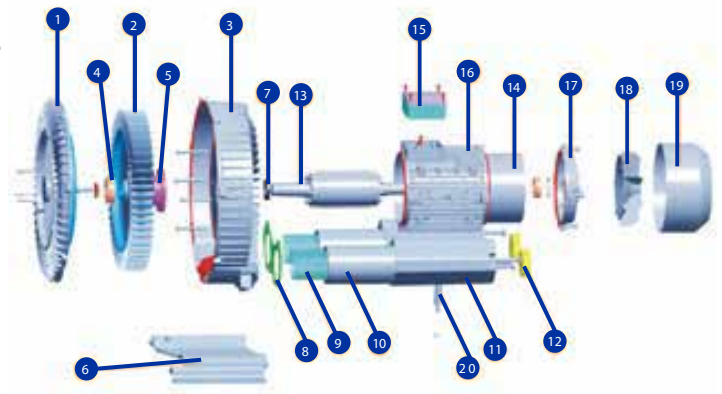
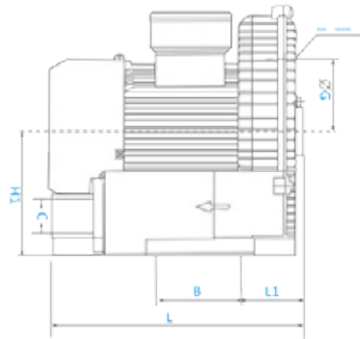
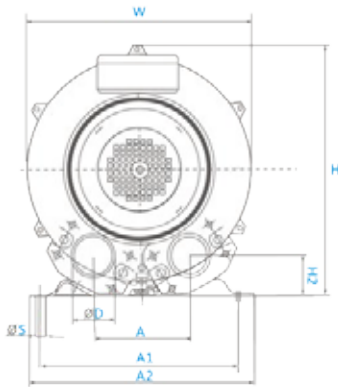

Código	Modelo		Flujo máx. m3/h	Presión máx. MCA	Vacío máx. MCA									
209461	1 HP GB750 - 220 Volt		145	2,2	- 1,8									
209465	2 HP GB1500 - 380 Volt		220	2,6	- 2,1									
209466	3 HP GB2200 - 380 Volt		325	3,6	- 2,8									
209468	4 HP GB3000 - 380 Volt		390	3,7	- 3,0									
Modelo	L	W	H	H1	H2	A	A1	A2	L1	B	G	D	S	C
HG - 750	300	286	302	165	58	111	225	265	80	90	Φ173	Φ 50	Φ 12	M 47
HG - 1500	325	335	340	190	61.5	115	270	300	30	140	Φ 200	Φ 60	Φ 14	M 60
HG - 2200	377	382	385	192	56	125	290	326	103	140	Φ 256	Φ 60	Φ 14	M 60
HG - 3000	402	408	410	210	56	140	313	345	103	140	Φ 256	Φ 60	Φ 14	M 60



Equipos de Riego
LAS BRUJAS DE TALAGANTE

www.equiposderiego.cl

BOMBAS SOPLANTES

1 HP - 2 HP - 3 HP - 4 HP

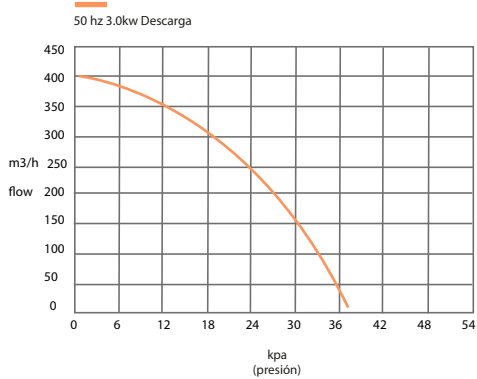
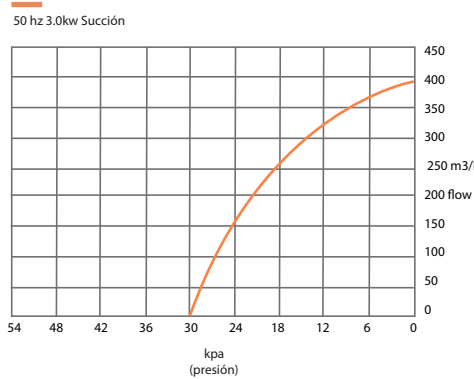
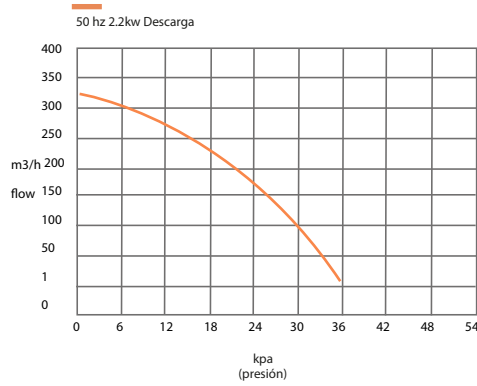
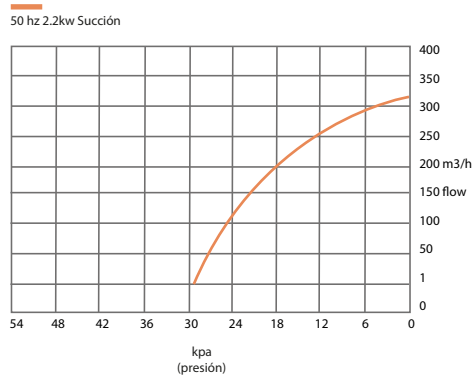
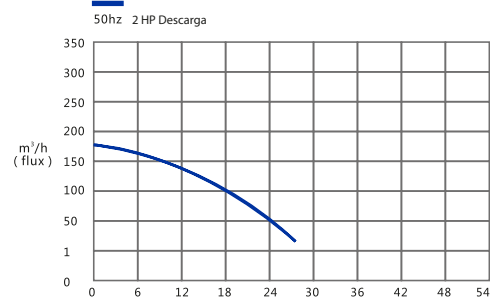
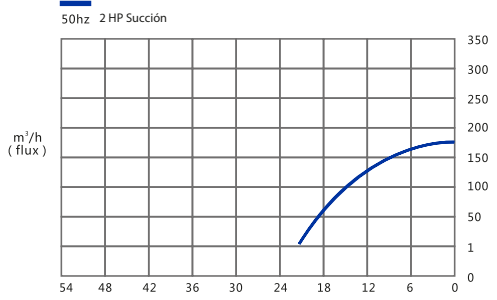
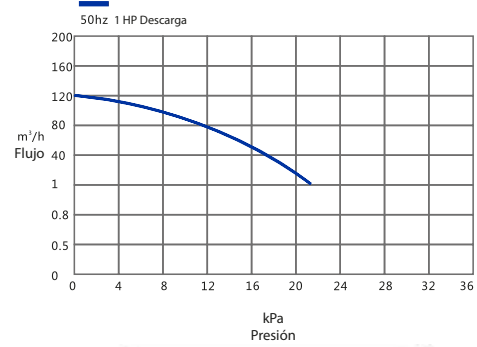
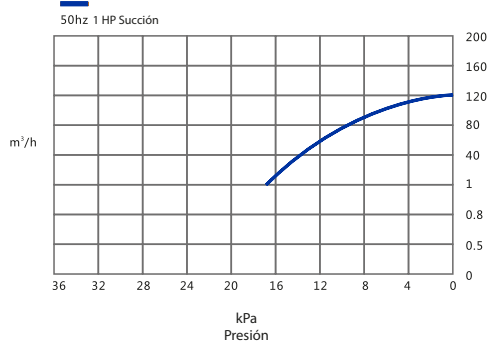

Equipos de Riego
LAS BRUJAS DE TALAGANTE

www.equiposderiego.cl