



# WORK TALL





OVER 25 YEARS  
**WORKING**  
**TALL**

SurPro is the name in stilts. We've been serving up superior drywall stilts to the pros since 1996. Our dedication to safety has allowed us to stand strong, but it's our passion for innovation that has kept us on top. Our commitment to safety, comfort and performance sets the industry standard. For those who demand the best, we stand with you and for you. Work tall with SurPro High-Performance Stilts.

**ABOUT US**



ALL STILTS ARE  
 HEIGHT ADJUSTABLE



NEW

**SIX** | PG. 17



+1-888-443-8889



help@stilts.com





RISE ABOVE INDUSTRY STANDARD.



SINGLE-SIDED STILTS

8

MAGNESIUM



9

ALUMINUM



MODEL INDEX



THE ULTIMATE IN ARTICULATION.



SINGLE-SIDED STILTS WITH  
*FLEXION*

NEW

11

MAGNESIUM



12

ALUMINUM



GREATER STABILITY & COMFORT.



DOUBLE-SIDED STILTS

14

MAGNESIUM



15

ALUMINUM



THE APEX IN DRYWALL STILTS.



DOUBLE-SIDED STILTS WITH  
*FLEXION*

NEW

17

MAGNESIUM



18

ALUMINUM





# SUPPORT



## FIND A DEALER



Locate a SurPro Dealer near you to compare features, try on stilts, get fitment advice, and purchase stilts and replacement parts. Our website showcases both storefronts and online stores.

[stilts.com/dealers](https://stilts.com/dealers)



## WARRANTY



Stilts.com and SurPro are divisions of The Forest Group, Inc. The Forest Group, Inc. offers a one-year limited warranty on the structural components of your SurPro Stilts against manufacturing defects from the date of purchase. See website for complete details.

[stilts.com/warranty](https://stilts.com/warranty)



## SPARE PARTS



Only use Genuine SurPro Parts on SurPro Stilts. We offer all of the quality replacement parts you'll need to keep your stilts like new. Check with your local dealer or shop online.

[stilts.com/parts](https://stilts.com/parts)



SurPro  
A division of The Forest Group, Inc.  
5600 Bonhomme Rd SteC  
Houston, TX 77036  
U.S.A.  
1 (888) 443-8889  
[help@stilts.com](mailto:help@stilts.com)

**STILTS.com**

# WHAT SIZE DO I NEED?

- 1 Find your height without stilts.
- 2 To calculate your height on stilts, add your height to the height of the stilts:  
  
(i.e. 5'3" + 26" = 7' 5")
- 3 Estimate your maximum reach on each of our size ranges.

## How high do you want to reach?

We offer different sizes of adjustable height stilts. Our most popular size is 26"-40", as they will lift your feet off the ground 26" (at minimum) and 40" (at maximum), and are adjustable in 2" increments in between the minimum and maximum height. A quick review of the table below shows how our 26"-40" stilts allow almost every user to reach 10' or higher, which makes them very popular among contractors working on residential and commercial ceilings. For example, the average male (5' 9") who is primarily working on 8 ft or 9 ft ceilings, may opt for a smaller size, like 20"-30" and an even taller person (say, someone 6' 1") will be able to reach the same height on a 16"-24". Keep in mind, maximum reach may be different than your working height. For example, if you want your hands at eye level, you can simply add the height of the stilts to your height and subtract a few inches. The stilts illustrations (see right) are shown as single-sided stilts, though these same sizes apply to our double-sided stilts. Give us a call if you have questions.

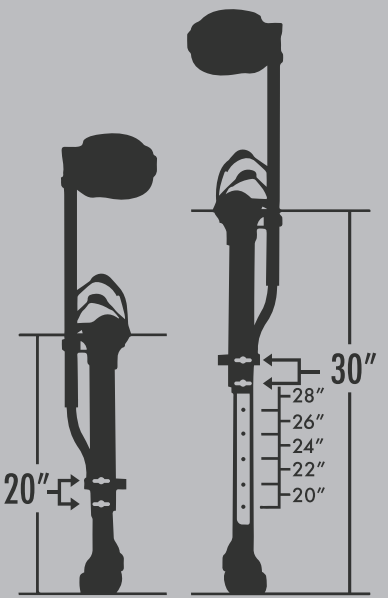
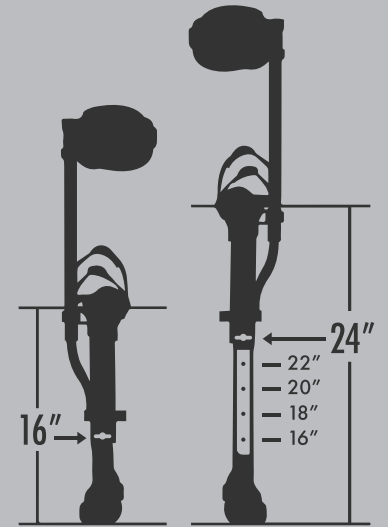

Add 1" for 21"-31" S1X/S2X

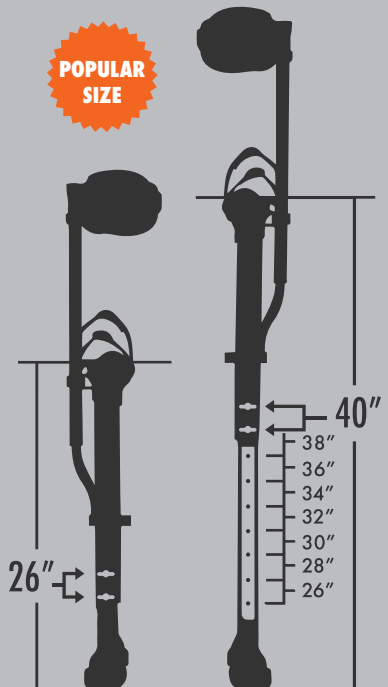

WITHOUT STILTS		MAXIMUM REACH WITH STILTS		
YOUR HEIGHT	YOUR MAX. REACH	16"-24"	20"-30"	26"-40"
5' 1"	6' 9"	8' 1" – 8' 8"	8' 5" – 9' 2"	8' 11" – 10'
5' 2"	6' 11"	8' 2" – 8' 9"	8' 6" – 9' 3"	9' – 10' 1"
5' 3"	7'	8' 3" – 9'	8' 7" – 9' 6"	9' 1" – 10' 4"
5' 4"	7' 1"	8' 4" – 9' 1"	8' 8" – 9' 7"	9' 2" – 10' 5"
5' 5"	7' 3"	8' 6" – 9' 3"	8' 10" – 9' 8"	9' 3" – 10' 6"
5' 6"	7' 4"	8' 7" – 9' 4"	8' 11" – 9' 10"	9' 4" – 10' 8"
5' 7"	7' 5"	8' 8" – 9' 5"	9' – 9' 11"	9' 6" – 10' 9"
5' 8"	7' 7"	8' 9" – 9' 6"	9' 1" – 10'	9' 7" – 10' 10"
5' 9"	7' 8"	9' – 9' 7"	9' 4" – 10' 1"	9' 10" – 10' 11"
5' 10"	7' 9"	9' 1" – 9' 8"	9' 5" – 10' 2"	9' 11" – 11'
5' 11"	7' 11"	9' 2" – 9' 9"	9' 6" – 10' 3"	10' – 11' 1"
6'	8'	9' 3" – 10'	9' 7" – 10' 6"	10' 1" – 11' 4"
6' 1"	8' 2"	9' 5" – 10' 1"	9' 9" – 10' 7"	10' 2" – 11' 5"
6' 2"	8' 3"	9' 6" – 10' 2"	9' 10" – 10' 8"	10' 4" – 11' 6"
6' 3"	8' 4"	9' 7" – 10' 3"	9' 11" – 10' 9"	10' 5" – 11' 7"
6' 4"	8' 6"	9' 8" – 10' 5"	10' – 10' 11"	10' 6" – 11' 9"
6' 5"	8' 7"	9' 9" – 10' 6"	10' 1" – 11'	10' 7" – 11' 10"
6' 6"	8' 8"	10' – 10' 7"	10' 4" – 11' 1"	10' 10" – 11' 11"
6' 7"	8' 10"	10' 1" – 10' 8"	10' 5" – 11' 2"	10' 11" – 12'
6' 8"	8' 11"	10' 2" – 10' 9"	10' 6" – 11' 3"	11' 1" – 12' 2"
6' 9"	9'	10' 3" – 11'	10' 7" – 11' 6"	11' 2" – 12' 4"

- █ Average female height
- █ Average male height

Table figures are approximate and based on averages. Tolerance +/- 1-2". See stilt models (S1, S1X, S2, and S2X) for size availability.



**SINGLE-SIDED  
DRYWALL STILTS**

# MODERN INNOVATION

The original Drywall Stilts, modernized. The superiority of these traditional drywall stilts are best illustrated in the field, after miles of comfort and years of dependability. These commercial grade stilts are the go-to for contractors looking for a safer, more comfortable, and efficient way to work tall. From top to bottom, you'll enjoy exclusive features like our flexible wraparound leg bands that won't cut into your calves, and our key and lock "no-twist" side poles that won't waste your time with constant adjustments. Our double wing bolts keep our stilts tight and secure at any height and add an extra layer of safety. Take a big step above industry standard with the S1.



**MAGNESIUM**

**PG.  
8**



**ITEM CODE**

**HEIGHT**

S1-M-1624  
S1-M-2030  
S1-M-2640

16"-24"  
20"-30"  
26"-40"

**ALUMINUM**

**PG.  
9**



**ITEM CODE**

**HEIGHT**

S1-A-1624  
S1-A-2030  
S1-A-2640

16"-24"  
20"-30"  
26"-40"

**MAGNESIUM**

**PG.  
11**



**ITEM CODE**

**HEIGHT**

-  
S1X-M-2131  
S1X-M-2640

-  
21"-31"  
26"-40"

**ALUMINUM**

**PG.  
12**



**ITEM CODE**

**HEIGHT**

-  
S1X-A-2131  
S1X-A-2640

-  
21"-31"  
26"-40"



COMFORT WRAPAROUND LEG BANDS  
W/ BLACK STRAPS



COMFORT WRAPAROUND LEG BANDS  
W/ SAFETY ORANGE STRAPS



KEY LOCK SIDE POLE CLAMPS WITH 3 LOCKING  
POSITIONS & HEIGHT ADJUSTABLE SIDE POLES



KEY LOCK SIDE POLE CLAMPS WITH 3 LOCKING  
POSITIONS & HEIGHT ADJUSTABLE SIDE POLES



**FLEXION**

FLEXION FOOT SYSTEM W/ ARTICULATION



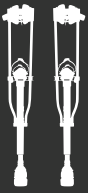

**DOUBLE-SIDED  
DRYWALL STILTS**

# NEXT-LEVEL STABILITY

The best balance and stability in the drywall stilts category. The ground breaking differentiator of these stilts are the dual side poles, which immediately increase the balance and stability of the stilts and user. The legs bands provide equal support to your entire calf and improve comfort. New users and seasoned pros that can overcome change should experience less fatigue and reduced stress on the body. This equates to better performance and increased safety. This sturdy-built design is well-loved among contractors seeking more comfort. The addition of the inside leg pole adds a learning curve for experienced single-sided stilts users not use to it being there.



**MAGNESIUM**  
**PG. 14**

**ALUMINUM**  
**PG. 15**

**MAGNESIUM**  
**PG. 17**

**ALUMINUM**  
**PG. 18**



ITEM CODE	HEIGHT	ITEM CODE	HEIGHT	ITEM CODE	HEIGHT	ITEM CODE	HEIGHT
S2-M-1624	16"-24"	S2-A-1624	16"-24"	-	-	-	-
S2-M-2030	20"-30"	S2-A-2030	20"-30"	S2X-M-2131	21"-31"	S2X-A-2131	21"-31"
S2-M-2640	26"-40"	S2-A-2640	26"-40"	S2X-M-2640	26"-40"	S2X-A-2640	26"-40"



360° COMFORT LEG BANDS



360° COMFORT ROCKER LEG BANDS



FIXED RECTANGULAR SIDE POLES W/ TAPERED INNER LEG & ADJUSTABLE CALF-HEIGHT



TELESCOPING RECTANGULAR SIDE POLES W/ TAPERED INNER LEG & ADJUSTABLE CALF-HEIGHT



**FLEXION**  
FLEXION FOOT SYSTEM W/ ARTICULATION



THE LIGHTEST & MOST DAMPING SINGLE-SIDED STILTS.

# Reduce weight and vibrations with magnesium.



## MAGNESIUM STILTS

Traditional style with modern advancements in safety, comfort, and performance. With magnesium being 33% lighter than aluminum, the stilt bodies on the S1 Magnesium Stilts reduce weight without sacrificing safety. Step above industry standard, save weight, and get the most popular single-sided stilts in the industry.

- Magnesium frames are lighter and have 10X damping versus aluminum to reduce vibrations
- Adjustable height in two inch increments
- Auto-locking buckles and premium cotton straps
- Adjustable dual-action spring for precise resistance
- Enhanced safety features throughout
- Wider foot plates for better footing and balance

MODEL NO.	HEIGHT	UPC	WEIGHT (EA.)
S1-M-1624	16"-24"	639945000334	6.35 LBS
S1-M-2030	20"-30"	639945000372	6.95 LBS
S1-M-2640	26"-40"	639945000426	7.7 LBS



### COMFORT WRAPAROUND LEG BANDS

Durable cordura construction with perforated breathable nylon to keep you cool, and full wraparound padding for plush comfort.



### KEY LOCK SIDE POLES & CLAMPS w/ HEIGHT ADJUST

While other poles twist and require constant adjustment, ours stay put and safely lock in place. Easily adjust the vertical and lateral position for a perfect fit and best balance.



### INTERLOCK ENHANCED SAFETY SYSTEM

Your side poles will never fly-free or slide down when you are using our stilts. We put safety first into every aspect of our stilts.



### DOUBLE WING BOLTS FRONT & BACK\*

Double the safety and internal parts longevity. Easily adjust height in two inch increments from minimum height to max.

MAGNESIUM



### NON-MARKING SUPER GRIP SOLES

Custom soles designed specifically for jobsite use.

\* 16"-24" stilts contain single wing bolt on the front and back.



THE MOST DURABLE SINGLE-SIDED STILTS.

# Continually raising the industry standard.



ALUMINUM STILTS

Traditional style with modern advancements in safety, comfort, and performance. After 25 years of jobsite proven success, S1 Stilts continue to raise the industry standard. Built to be a commercial-grade workhorse with the grace and refinements of a thoroughbred. A staple in the drywaller's tool box and an icon for safety.

- Durable aluminum construction
- Adjustable height in two inch increments
- Auto-locking buckles and premium cotton straps
- Adjustable dual-action spring for precise resistance
- Enhanced safety features throughout
- Wider foot plates for better footing and balance

MODEL NO.	HEIGHT	UPC	WEIGHT (EA.)
S1-A-1624	16"-24"	639945000341	6.45 LBS
S1-A-2030	20"-30"	639945000389	7.15 LBS
S1-A-2640	26"-40"	639945000440	7.95 LBS

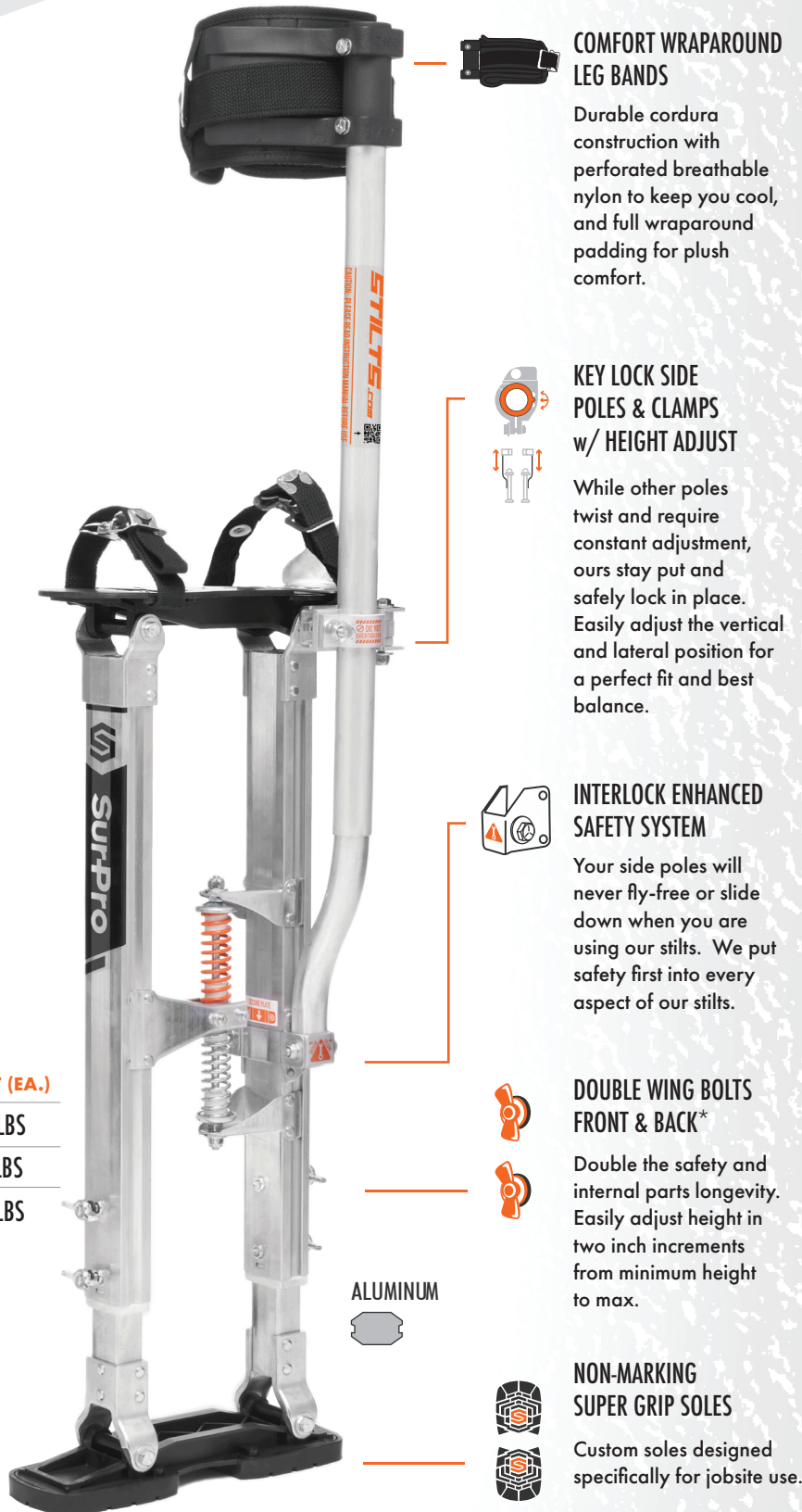

### COMFORT WRAPAROUND LEG BANDS

Durable cordura construction with perforated breathable nylon to keep you cool, and full wraparound padding for plush comfort.

### KEY LOCK SIDE POLES & CLAMPS w/ HEIGHT ADJUST

While other poles twist and require constant adjustment, ours stay put and safely lock in place. Easily adjust the vertical and lateral position for a perfect fit and best balance.

### INTERLOCK ENHANCED SAFETY SYSTEM

Your side poles will never fly-free or slide down when you are using our stilts. We put safety first into every aspect of our stilts.

### DOUBLE WING BOLTS FRONT & BACK\*

Double the safety and internal parts longevity. Easily adjust height in two inch increments from minimum height to max.

### NON-MARKING SUPER GRIP SOLES

Custom soles designed specifically for jobsite use.

ALUMINUM

\* 16"-24" stilts a contain single wing bolt on the front and back.



+1-888-443-8889



help@stilts.com



# PERFORMANCE DRIVEN

We've known Brian Kitchin since before he founded the leading YouTube Channel for drywall enthusiasts - Drywall Nation. He's a big fan of our Stilts, and we value his opinions and input on our stilt designs. Before we launched the X model stilts, we sent a pair of single sided S1X Stilts and a pair of double sided S2X Stilts for his feedback. Scan the QR code or visit the YouTube URL to see real world performance.



<https://youtu.be/Lq1rYsivOLQ>



WHAT DID HE THINK?

# "I LOVE 'EM"

Brian Kitchin, Drywall Nation

 Sur-Pro®

HIGH PERFORMANCE  
**STILTS**

THE HIGHEST PERFORMANCE

# The ultimate in stilts articulation.



MAGNESIUM STILTS

The SurPro SIX is the most advanced and feature-rich single-sided stilts to date. Reach new heights in safety, comfort, and performance. Exclusive Flexion Foot System provides unparalleled articulation and a more natural walking feel during lift, which is 40-60% of the walking motion. With magnesium being 33% lighter than aluminum, these stilt bodies reduce weight without sacrificing safety. Built for commercial drywall contractors that demand safety-first and traditional style.

- Magnesium frames are lighter and have 10X damping versus aluminum to reduce vibrations
- New Flexion Foot provides the most natural walking feel
- Adjustable height in two inch increments
- Auto-locking buckles and premium cotton straps
- Adjustable dual-action spring for precise resistance
- Enhanced safety features throughout
- Wider foot plates for better footing and balance

MODEL NO.	HEIGHT	UPC	WEIGHT (EA.)
SIX-M-2131	21"-31"	639945000808	7.55 LBS
SIX-M-2640	26"-40'	639945000471	8.05 LBS



**FLEXION**

Gain additional traction and achieve a more natural stride with the Flexion Foot System. The compression spring helps to reduce impact and stress on the body, thus increasing daily performance and comfort. Exclusive to SurPro "X Models".



### COMFORT WRAPAROUND LEG BANDS

Durable cordura construction with perforated breathable nylon to keep you cool, and full wraparound padding for plush comfort. Safety orange Leg Band Straps.



### KEY LOCK SIDE POLES & CLAMPS w/ HEIGHT ADJUST

While other poles twist and require constant adjustment, ours stay put and safely lock in place. Easily adjust the vertical and lateral position for a perfect fit and best balance.



### INTERLOCK ENHANCED SAFETY SYSTEM

Your side poles will never fly-free or slide down when you are using our stilts. We put safety first into every aspect of our stilts.



### DOUBLE WING BOLTS FRONT & BACK\*

Double the safety and internal parts longevity. Easily adjust height in two inch increments from minimum height to max.

MAGNESIUM



### NON-MARKING SUPER GRIP SOLES

Custom soles designed specifically for jobsite use.

**FLEXION**



+1-888-443-8889



help@stilts.com

# FLEXION

Gain additional traction and achieve a more natural stride with the Flexion Foot System. The compression spring helps to reduce impact and stress on the body, thus increasing daily performance and comfort. Exclusive to SurPro "X Models".



## PERFORMANCE & DURABILITY

# Superior strength & articulation.

### COMFORT WRAPAROUND LEG BANDS

Durable cordura construction with, perforated breathable nylon to keep you cool, and full wraparound padding for plush comfort. Safety orange Leg Band Straps.

### KEY LOCK SIDE POLES & CLAMPS w/ HEIGHT ADJUST

While other poles twist and require constant adjustment, ours stay put and safely lock in place. Easily adjust the vertical and lateral position for a perfect fit and best balance.

### INTERLOCK ENHANCED SAFETY SYSTEM

Your side poles will never fly-free or slide down when you are using our stilts. We put safety first into every aspect of our stilts.

### DOUBLE WING BOLTS FRONT & BACK\*

Double the safety and internal parts longevity. Easily adjust height in two inch increments from minimum height to max.

### NON-MARKING SUPER GRIP SOLES

Custom soles designed specifically for jobsite use.



## SurPro®



ALUMINUM STILTS

The SurPro S1X is the most advanced and feature-rich single-sided stilts to date. Reach new heights in safety, comfort, and performance. Exclusive Flexion Foot System provides unparalleled articulation and a more natural walking feel during lift, which is 40-60% of the walking motion. Built for commercial drywall contractors that demand safety-first and traditional style, while needed a little extra strength to ensure long-lasting durability.

- Durable aluminum construction
- New Flexion Foot provides the most natural walking feel
- Adjustable height in two inch increments
- Auto-locking buckles and premium cotton straps
- Adjustable dual-action spring for precise resistance
- Enhanced safety features throughout
- Wider foot plates for better footing and balance

MODEL NO.	HEIGHT	UPC	WEIGHT (EA.)
S1X-A-2131	21"-31"	639945000839	7.6 LBS
S1X-A-2640	26"-40'	639945000815	8.1 LBS

ALUMINUM





## DOUBLE-SIDED DRYWALL STILTS

# REDUCE FATIGUE

Better stability equates to less fatigue. Whereas the "1" in S1 represents a traditional single side pole design, the "2" in S2 represents our revolutionary double sided pole design. Contractors that make the switch to double-sided stilts will feel the benefits after prolonged use. The increased stability and balance of the symmetrical design reduces fatigue and promotes better performance. Both sides of the user's leg are equally supported by side poles and a 360 degree wrap around leg band. Whether the user is a new stilt walker or a seasoned pro, the added stability, reduction in fatigue, and increased comfort will all lead to better overall performance and worker safety. Even though these stilts are a bit heavier out of the box, most users tell us that they actually feel lighter than traditional stilts when working on them. Choose from our popular S2 models or the latest generation S2X models (as pictured) with the **New Rocker Leg Bands and Flexion Foot System** to achieve the most natural walking feel.



- REDUCE FATIGUE & INCREASE PERFORMANCE
- MAXIMIZE COMFORT & ELEVATE THE WORKING EXPERIENCE
- NEXT-LEVEL STABILITY & SAFETY



PGS.  
14-15



PGS.  
16-18

THE LIGHTEST DOUBLE-SIDED DRYWALL STILTS.

# Our lightest dual side pole stilts and the most popular among drywall pros.



SurPro®

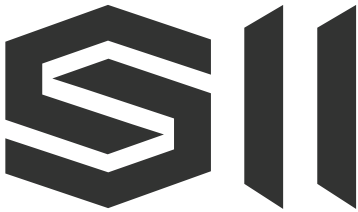

MAGNESIUM STILTS

SurPro set the bar and then broke it with the invention of double-sided stilts. The newly updated SurPro S2 maximizes everyday performance by further elevating your comfort and stability. Better balance and comfort equate to less fatigue and added performance. Step into our best-selling stilts for contractors worldwide. With magnesium being 33% lighter than aluminum, the stilt bodies on the S2 Magnesium Stilts reduce weight without sacrificing safety.

- Magnesium frames are lighter and have 10X damping versus aluminum to reduce vibrations
- Durable aluminum construction
- Dual side poles for best balance and less fatigue
- Adjustable height in two inch increments
- Auto-locking buckles and premium cotton straps
- Adjustable dual-action spring for precise resistance
- Enhanced safety features throughout
- Wider foot plates for better footing and balance

MODEL NO.	HEIGHT	UPC	WEIGHT (EA.)
S2-M-1624	16"-24"	639945000358	7.1 LBS
S2-M-2030	20"-30"	639945000396	7.85 LBS
S2-M-2640	26"-40"	639945000457	8.65 LBS



### 360° COMFORT LEG BANDS

Durable cordura construction with perforated breathable nylon to keep you cool and dry. Maximum security and 360-degree of plush comfort.



### RECTANGULAR SIDE POLES W/ TAPERED INNER LEG & ADJUSTABLE CALF-HEIGHT

While other side poles twist and require constant adjustment, ours stay put and safely lock in place. Adjustable calf-height for a comfy fit.



### INTERLOCK ENHANCED SAFETY SYSTEM

Your side poles will never fly-free or slide down when you are using our stilts. We put safety first into every aspect of our stilts.



### DOUBLE WING BOLTS FRONT & BACK\*

Double the safety and internal parts longevity. Easily adjust height in two inch increments from minimum height to max.



MAGNESIUM



### NON-MARKING SUPER GRIP SOLES

Custom soles designed specifically for jobsite use.



\*16"-24" stilts a contain single wing bolt on the front and back.

THE ICON OF BALANCE & STRENGTH.

# Achieve greater balance, stability, and comfort with dual side poles.

## SurPro®

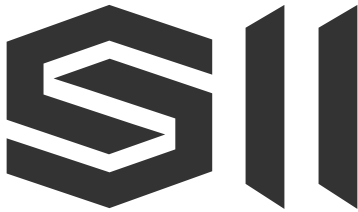

### ALUMINUM STILTS

SurPro set the bar and then broke it with the invention of double-sided stilts. The newly updated SurPro S2 maximizes everyday performance by further elevating your comfort and stability. Better balance and comfort equate to less fatigue and added performance. Step into our best-selling stilts for contractors, worldwide.

- Durable aluminum construction
- Dual side poles for best balance and less fatigue
- Adjustable height in two inch increments
- Auto-locking buckles and premium cotton straps
- Adjustable dual-action spring for precise resistance
- Enhanced safety features throughout
- Wider foot plates for better footing and balance

MODEL NO.	HEIGHT	UPC	WEIGHT (EA.)
S2-A-1624	16"-24"	639945000365	7.3 LBS
S2-A-2030	20"-30"	639945000402	7.95 LBS
S2-A-2640	26"-40"	639945000464	8.75 LBS



#### 360° COMFORT LEG BANDS

Durable cordura construction with perforated breathable nylon to keep you cool and dry. Maximum security and 360-degree of plush comfort.



#### RECTANGULAR SIDE POLES W/ TAPERED INNER LEG & ADJUSTABLE CALF-HEIGHT

While other side poles twist and require constant adjustment, ours stay put and safely lock in place. Adjustable calf-height for a comfy fit.



#### INTERLOCK ENHANCED SAFETY SYSTEM

Your side poles will never fly-free or slide down when you are using our stilts. We put safety first into every aspect of our stilts.



#### DOUBLE WING BOLTS FRONT & BACK\*

Double the safety and internal parts longevity. Easily adjust height in two inch increments from minimum height to max.

ALUMINUM



#### NON-MARKING SUPER GRIP SOLES

Custom soles designed specifically for jobsite use.



+1-888-443-8889



help@stilts.com

\*16"-24" stilts a contain single wing bolt on the front and back.



# THE BEST YET.

The S2X Stilts represent our most feature-rich stilts to date. Customers are giving them the highest of praises. We think they're pretty darn fine. Our double-sided design has been a huge success for us over the years. People that switch over to them from traditional stilts, or start out on them, typically become evangelists of our brand. It was only fitting that we went all out to deliver an epic pair of drywall stilts for our fans worldwide. For contractors that want the best we have to offer, the S2X Stilts are it. Available in Magnesium or Aluminum bodies.

# SIX

**Sur-Pro**

HIGH PERFORMANCE  
**STILTS**



**STILTS.com**



THE ULTIMATE DRYWALL STILTS.

# The apex in stilts, and our most feature-rich drywall stilts to date.

## SurPro®



MAGNESIUM STILTS

The SurPro S2X is as good as it gets. Maximize everyday performance by further elevating your comfort and stability. Better balance and comfort equate to less fatigue, and S2X does it best. New Rocker Leg Bands utilize our popular Comfort Wraparound System with the added benefit of rocking forward and backward with your legs, thus reducing resistance and increasing comfort. Plus, they can be easily raised and lowered to adjust to your desired calf height and size. Exclusive Flexion Foot System provides unparalleled articulation and a more natural walking feel. Step up to S2X.

- Magnesium frames are lighter and have 10X damping versus aluminum to reduce vibrations
- New Rocker Leg Bands reduces stress and add comfort
- New Flexion Foot provides the most natural walking feel
- Adjustable height in two inch increments
- Auto-locking buckles and premium cotton straps
- Adjustable dual-action spring for precise resistance
- Enhanced safety features throughout
- Wider foot plates for better footing and balance

MODEL NO.	HEIGHT	UPC	WEIGHT (EA.)
S2X-M-2131	21"-31"	639945000792	8.5 LBS
S2X-M-2640	26"-40"	639945000488	9 LBS



## FLEXION

Gain additional traction and achieve a more natural stride with the Flexion Foot System. The compression spring helps to reduce impact and stress on the body, thus increasing daily performance and comfort. Exclusive to SurPro "X Models".



### 360° COMFORT LEG BANDS

Durable cordura construction with perforated breathable nylon to keep you cool and dry. Maximum security and 360-degree of plush comfort.



### RECTANGULAR SIDE POLES W/ TAPERED INNER LEG & ADJUSTABLE CALF-HEIGHT

While other side poles twist and require constant adjustment, ours stay put and safely lock in place. Adjustable calf-height for a comfy fit.

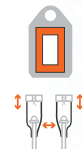

### INTERLOCK ENHANCED SAFETY SYSTEM

Your side poles will never fly-free or slide down when you are using our stilts. We put safety first into every aspect of our stilts.



### DOUBLE WING BOLTS FRONT & BACK\*

Double the safety and internal parts longevity. Easily adjust height in two inch increments from minimum height to max.



### NON-MARKING SUPER GRIP SOLES

Custom soles designed specifically for jobsite use.



## FLEXION



+1-888-443-8889



help@stilts.com

# Now available in durable aluminum bodies.

SurPro®



## ALUMINUM STILTS

The SurPro S2X Aluminum Stilts are exactly the same as our S2X Magnesium Stilts, except built with aluminum bodies and silver anodize. These are the go-to stilts for contractors looking for maximum strength and comfort. Elevate everyday comfort and while increasing stability and durability. Better balance and comfort equate to less fatigue, and S2X does it best. New Rocker Leg Bands utilize our popular Comfort Wraparound System with the added benefit of rocking forward and backward with your legs, thus reducing resistance and increasing comfort. Plus, they can be easily raised and lowered to adjust to your desired calf height and size. Exclusive Flexion Foot System provides unparalleled articulation and a more natural walking feel. Step up to S2X.

- Durable aluminum construction
- New Rocker Leg Bands reduces stress and add comfort
- New Flexion Foot provides the most natural walking feel
- Adjustable height in two inch increments
- Auto-locking buckles and premium cotton straps
- Adjustable dual-action spring for precise resistance
- Enhanced safety features throughout
- Wider foot plates for better footing and balance



MODEL NO.	HEIGHT	UPC	WEIGHT (EA.)
S2X-A-2131	21"-31"	639945000846	8.6 LBS
S2X-A-2640	26"-40"	639945000822	9.1 LBS





# GENUINE PARTS

ALWAYS USE GENUINE SURPRO PARTS.

Inspect your stilts before each use. Wear items, like straps and soles, will need to be replaced more frequently. Pick up spares and have them on hand to eliminate downtime and ensure safety. To find an authorized dealer near you visit [stilts.com/dealers](http://stilts.com/dealers)

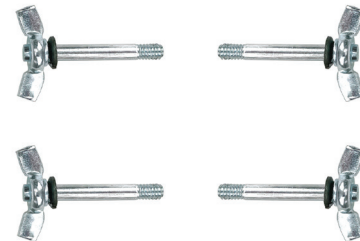

GENUINE SURPRO STILTS PARTS



[stilts.com/parts](http://stilts.com/parts)

INSTRUCTION MANUALS & PARTS DIAGRAM



[stilts.com/diagrams](http://stilts.com/diagrams)



STILTS  
COM



**SurPro**

**A division of The Forest Group, Inc.**

**5600 Bonhomme Rd Ste C**

**Houston, TX 77036 U.S.A.**

**1 (888) 443-8889**

**help@stilts.com**

**stilts.com**



SCAN CODE