

Excision

BI



# Product Guide

Edition 22



**Excision**<sup>®</sup>  
Dependable Precision

## Who We Are



Dependable Precision is at the heart and foundation of everything we do.



Welcome to this insight of Excision, Australia's leading manufacturer and wholesaler of industrial cutting products and consumables such as bandsaw blades, coldsaw blades, coolants, punches & dies and more.

With Excision being in the industry for over 29 years, we have proved that high quality products give high performance. Quality machinery and consumables translate into more cost effective operations. When you deal with us, you will receive the expert technical support and industrial knowledge to maximise your output.

Our goal is to always provide you with quality, range and value for money – and our standards are high. We offer extensive warranties with a full back-up service, expert advice, training and sales support.

Excision is a family, Australian-owned and operated company.



# What's Inside



**6** Bandsaw Blades



**102** Holesaws & Accessories



**36** Circular Blades



**112** Punch & Die Tooling



**48** Metal Working Fluids



**118** Metal Cutting Machines



**72** Magnetic Based Drills



**142** Metal Preparing Machines



**90** Core Drills & Accessories



**158** Industrial Clamps

# Distribution

Combining world's best cutting technologies and products together under one brand and under one standard - Excision Dependable Precision.

## Excision® Advantage

Dependable Precision

 Quality premium suppliers of high grade steel, premium quality oil and precision equipments are shipped from all over the world to our head quarters ensuring constant supply & quality standard.



QUALITY STANDARD

QUALITY ASSURANCE



THE BEST TOTAL CUTTING SOLUTION FOR YOUR BUSINESS AND YOUR MACHINE FOR OVER 29 YEARS



In order to provide our valued customers the total solution package we have offices and warehouses in Victoria (HQ), Perth, Brisbane, Sydney and New Zealand.

**Head Quarters**  
**Excision Hamilton**  
35 Peck St,  
Hamilton, Vic 3300.

Here at Excision we provide the best cutting solutions in the market



# Expertise In Cutting



## We know cutting

- Over 29 years in providing steel cutting consumables and equipment.
- Technical approach - what is the best blade for your job.
- Solution to every cutting situation
- No limit to sourcing - We can source many cutting products from around the world.
- We manufacture in Australia a complete range of metal working fluids, cutting oils, spray mist oils etc... to assist.



## When cutting steel you have many variables that affect the cut;

- Condition of saw - quality of guides and tension of saw
- Blade quality and suitability
- Coolant quality - good oils add tool life

## Excision has the solution to all these;

- We can offer parts for machinery and also supply top quality alternatives
- Only source the best materials available for cutting - also have the widest range of types in Australia
- Only manufacture the highest quality cutting oils. We use only new oils and additives and do not allow recycled or substandard base oils to be used.

## We can cover all needs for your machine

We have all that you need to keep your cutting dependable - blades, fluids, machines, brushes, pumps etc.



SCAN TO  
PLAY VIDEO



SCAN TO  
VIEW LINK



## Bandsaw **Blades**



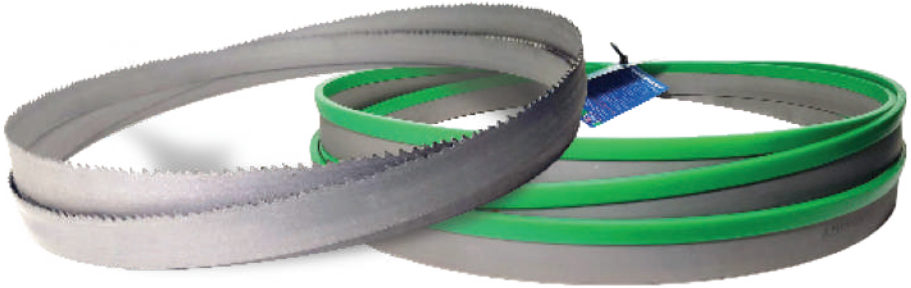

Excision has access to a large variety of bandsaw blades with unique geometry and composition, meaning we can offer a bespoke solution to every cutting job. From bi-metal to carbide to diamond to many other compositions - Excision has it all.



## 14-23

Metal & Aluminium Cutting Blades



## 24-27

Timber/Plastic Cutting Blades



## 28-29

Meat & Food Cutting Blades

# Bandsaw Blades

## How to buy a Bandsaw Blade

A Bandsaw Blade has 3 important dimensions

- Width
- Length
- Tooth Pitch (Usually measured in Teeth Per Inch known as TPI.)

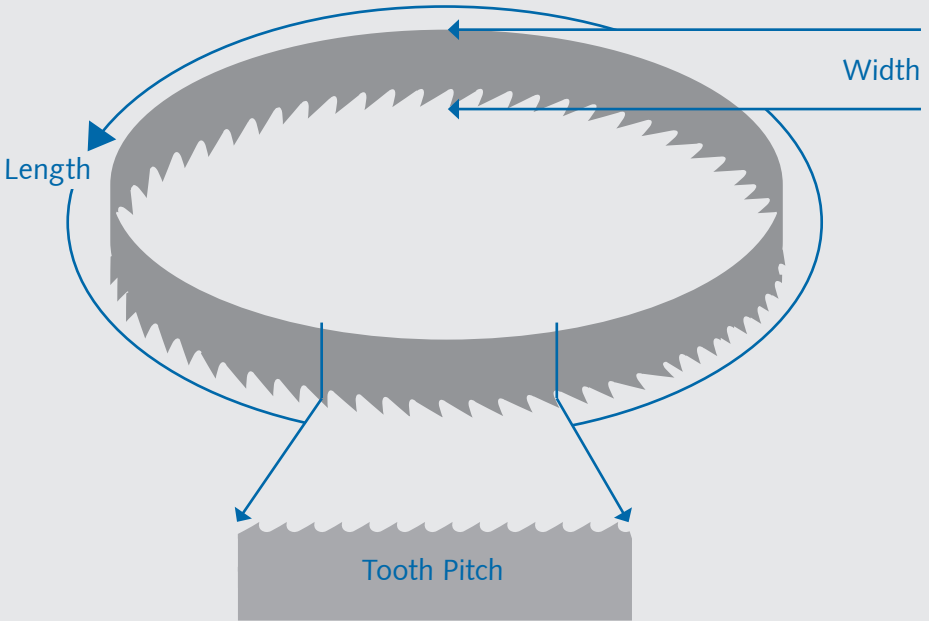

## Blade width

Blade width is measured from the tip of the blade to the back of the blade. Metal cutting bandsaws are normally specified on the machine by the manufacturer. Wood cutting bandsaws or vertical bandsaws can have multiple widths. If your saw has this option refer to page 35 for different options.

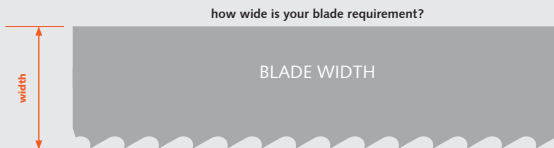



# Bandsaw Blades

## Measure Blade Length

Adjust the wheels of the machine to their correct position (about the middle of the adjustment range)

- Referring to the diagram below, measure the distance between the centre point of each wheel in mm (measurement D).
- Now measure the radius of each wheel in mm (R1 and R2).
- Use this formula to calculate the band length

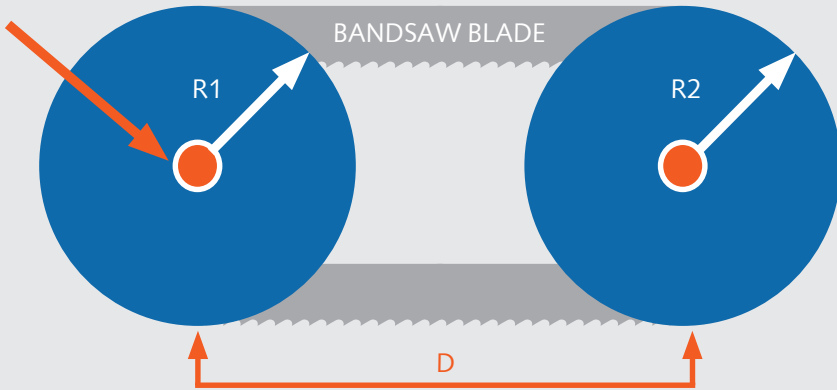

$$\text{Band Length In mm} = (R1 \times 3.1416) + (R2 \times 3.1416) + (2 \times D)$$

## Tooth Pitch

The tooth pitch describes the number of teeth per inch (TPI). You must select the correct tpi for the thickness of material you are cutting. If the correct tpi is not chosen the blade life will be dramatically shortened. Refer to page 32-35 for more detail.

For combi or variable toothing the first figure represents the largest distance between tooth tips and the second figure the smallest distance between tooth tips within one group.

### **Constant tooth pitch**

This tooth pitch has a constant distance from tooth to tooth. It is very suitable for cross sections and non-ferrous materials.



### **Combi / Variable tooth pitch**

The combi tooth pitch has different tooth tip distances within one toothing group. The application area of the band saw blade is increased and vibrations are reduced



# Bandsaw Blades

## Basic part number system

First 3 digits are the Type of material.  
 Next 2 digits are width in mm.  
 Next 3 digits represent TPI  
 Last 4/5 digits represent Length in mm

	Code   Width   TPI – Length
Example 1:	Bi-Alfa Cobalt M42 – 27mm x 10/14TPI x 2480 620   27   114 – 2480 = 62027114-2480
Example 2:	HM-Titan B0 – 41mm x 2/3TPI x 5450 675   41   203 – 5450 = 67541203-5450
Example 3:	Bi-Alfa Master Supreme – 80mm x 0.75/1.25TPI x 12300 650   80   071 – 12300 = 65080071-12300

**Please note:**

The above is a guide only. Some part numbers vary with different thicknesses, sets and TPIs.

TYPE	PREFIX
Bandknife NB	600
Bandknife DBSE	601
Bandknife DBDE	602
Bandknife Scallop	603
Carbon Thin Gauge	605
Carbon Flexback	610
Meat & Fish - 0.5	611
Meat & Fish - 0.6	612
Carbon Forestry	615
Bi-Alfa Cobalt M42	620
Bi-Alfa WS ALU	622
Bi-Alfa Forestry	623

TYPE	PREFIX
Bi-Alfa Profile – Original	624
Bi-Alfa Profile	625
Bi-Alfa Profile WS	626
Bi-Alfa RP	634
Bi-Alfa Cobalt Extreme	645
Bi-Alfa Master Supreme	650
Carbide Grit Gulleted	670
Carbide Grit Continuous	671
HM-Titan B0	675
HM-Titan ALU	680
HM-Titan MU	685

# Bandsaw Blades

## Explanation of Icons

Due to the variety of our band saw blades, we are able to cover a wide range of applications. The following icons indicate which band saw blade fits best to your individual cutting job.

	Thin-walled Tubes		Square Tubes	W S	Wide Set
	Thick-walled Tubes		Square Solids		Set Pattern
	Round Solids		Plate		Rake Angle
	Small Round Solids		Plates		Engine Block
	Thick-walled Tubes and Solid Bars		Angles		Foundry Cutting
	Bundled Solids		Profiles		Aluminum
	Round Tubes in Bundles		Square Tubes in Bundles		Angles
	Bundled Angles		T-, I- and L-Beams		Bundled Beams
	Timber		Food Cutting		PU Foam & Packaging
	Rubber Tyre		Lettuce & Vegetables		Bread & Pastries
	Glass Reinforced Plastic		Plastic		Ceramics
	Cast Iron		Graphite		Wire reinforced rubber
	Aerated Concrete		Carbon		

# Bandsaw Blades

## Comparison Table

Legend:

Best



Better



Good



Not Applicable

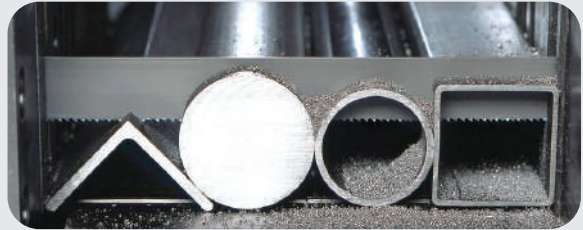

Bandsaw Type	Material						Profile		
	Aluminium	Mild Steel	Stainless Steel	Over 50HC	Copper or Brass	Structural Steel	Tube/ Pipe	Solids	Pack Cutting
Bi-Alfa Cobalt M42	★★★	★★★★	★★★	★	★★★★	★★★	★★★★	★★★★	★★★
Profile M42	★★★	★★★★	★	★	★	★★★★	★★★★	★	★★★★
Bi-Alfa WS Alu	★★★★	★	★★★		★★★★		★★★	★★★★	★
Bi-Alfa RP	★	★★★	★★★★	★★★	★★★★	★	★	★★★★	★
Cobalt Extreme	★★★	★★★	★★★★	★★★		★	★	★★★★	
Master Supreme	★★★	★★★★	★★★★	★★★★	★★★★	★	★	★★★★	
TCT Alu	★★★★				★★★★		★★★	★★★★	★
TCT B0	★	★★★	★★★★	★★★★	★	★	★★★	★★★★	★
TCT MU	★★★	★★★★	★★★★	★★★	★★★	★★★	★★★★	★★★★	★★★

# Bandsaw Blades

## Comparison Table

### Legend:

- Best** ★★★★★
- Better** ★★★★
- Good** ★★★
- Not Applicable** □



Bandsaw Type	Material				
	Masonry	Rubber	Ceramics	Glass	Graphite/Carbon
Carbide Grit	★★★	★★★★	★★★	★★★	★★★★
Diamond Grit	★★★★	★★★	★★★★	★★★★	★★★

Bandsaw Type	Material				
	Hardwood	Softwood	Plastics	Ripping	Fine Sawn
Carbon Flexback	★★★	★★★★	★★★★	★★★	★★★★
Carbon Thin Gauge	★★	★★★★	★★★	★★	★★★★
Carbon Forestry	★★★	★★★★	★★	★★★★	★★
Bi-Alfa Cobalt Forestry	★★★★	★★★★	★★	★★★★	★★

Bandsaw Type	Material					
	Meat	Fish	Frozen Meat	Bread	Vegetables	Foam
Meat & Fish	★★★★	★★★★	★★★	★★	★★	□
Bandknife	★★	★★★	★★★	★★★★	★★★★	★★★★

# Bandsaw Blades

## Bi-alfa Cobalt M42

The EXCISION bi-alfa cobalt band saw blade has HSS-M42 cutting tips. The high wear resistance of the band saw blade results from the very hard and evenly distributed carbides in the tooth tips, formed during the hardening and tempering process.

The martensitic structure of the tooth tips and the high cobalt content create excellent heat resistance and toughness reducing wear rates at high sawing speeds. With a high chromium backing, the saw blade can withstand the considerable flexing stresses, tension and blade guide pressure.

SIZE	CODE
6 X 0.6 X 6	62006006
6 X 0.9 X 6	620069006
6 X 0.9 X 10	620069010
6 X 0.9 X 14	620069014
6 X 0.6 X 10/14	62006114
6 X 0.9 X 10/14	620069114
10 X 0.6 X 6	62010006
10 X 0.6 X 10/14	62010114
10 X 0.9 X 4	620109004
10 X 0.9 X 6	620109006
10 X 0.9 X 8	620109008
10 X 0.9 X 10	620109010
10 X 0.9 X 14	620109014
10 X 0.9 X 10/14	620109114



Normal Tooth (N)

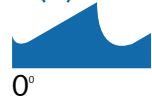

Hook Tooth

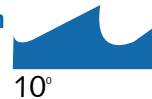

The hook tooth has a positive cutting angle of 10°. This tooth form is particularly suitable for cutting solid, thick-walled tubes and all higher-grade alloy material.



### Application areas

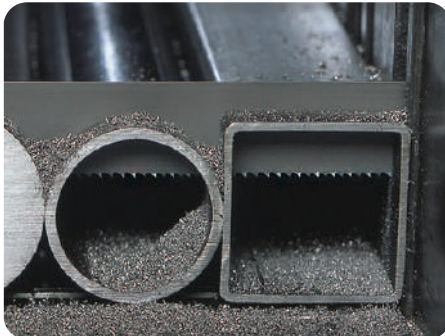
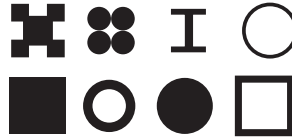

Wanting to increase your blade life? Why not try Excision coolant?

**XDP1000**





# Bandsaw Blades

## Bi-alfa Cobalt M42

Premium M42 cutting tips, ideal for general machining of steel up to tensile strength of 44hrc

SIZE	CODE
13 X 0.5 X 14	620135014
13 X 0.5 X 18	620135018
13 X 0.5 X 24	620135024
13 X 0.6 X 3	62013003
13 X 0.6 X 4	62013004
13 X 0.6 X 6	62013006
13 X 0.6 X 10	62013010
13 X 0.6 X 24	62013024
13 X 0.6 X 6/10	62013610
13 X 0.6 X 8/12	62013812
13 X 0.6 X 10/14	62013114
13 X 0.9 X 3	620139003
13 X 0.9 X 4	620139004
13 X 0.9 X 6	620139006
13 X 0.9 X 8	620139008
13 X 0.9 X 10	620139010
13 X 0.9 X 14	620139014
13 X 0.9 X 10/14	620139114
20 X 0.9 X 14	62020014
20 X 0.9 X 18	62020018
20 X 0.9 X 4/6	62020406
20 X 0.9 X 5/8	62020508
20 X 0.9 X 6/10	62020610
20 X 0.9 X 8/12	62020812
20 X 0.9 X 10/14	62020114
27 X 0.9 X 2	62027002
27 X 0.9 X 2 WS	62127002
27 X 0.9 X 10	62027010
27 X 0.9 X 14	62027014
27 X 0.9 X 18	62027018
27 X 0.9 X 2/3	62027203
27 X 0.9 X 3/4	62027304
27 X 0.9 X 4/5	62027405
27 X 0.9 X 4/6	62027406
27 X 0.9 X 5/8	62027508
27 X 0.9 X 6/10	62027610
27 X 0.9 X 8/12	62027812
27 X 0.9 X 10/14	62027114
34 X 1.1 X 1.25	62034125

SIZE	CODE
34 X 1.1 X 2/3	62034203
34 X 1.1 X 2/3 WS	62134203
34 X 1.1 X 3/4	62034304
34 X 1.1 X 3/4 WS	62134304
34 X 1.1 X 4/5	62034405
34 X 1.1 X 4/6	62034406
34 X 1.1 X 4/6 WS	62134406
34 X 1.1 X 8/12	62034812
41 X 1.3 X 1.25	62041125
41 X 1.3 X 1.5/2	62041152
41 X 1.3 X 2/3	62041203
41 X 1.3 X 2/3 WS	62141203
41 X 1.3 X 3/4	62041304
41 X 1.3 X 4/5	62041405
41 X 1.3 X 4/6 WS	62141406
41 X 1.3 X 5/8	62041508
41 X 1.3 X 6/10	62041610
54 X 1.3 X 1.25	62054125
54 X 1.6 X 0.75/1.25	62054071
54 X 1.3 X 1.1/1.6	62054116
54 X 1.3 X 1.5/2	62054152
54 X 1.3 X 2/3	62054203
54 X 1.6 X 2/3 WS	62154203
54 X 1.6 X 3/4	62054304
54 X 1.6 X 3/4 WS	62154304
54 X 1.6 X 4/6	62054406
67 X 1.6 X 1.25	62067125
67 X 1.6 X 0.75/1.25	62067071
67 X 1.6 X 1.1/1.6	62067116
67 X 1.6 X 1.5/2	62067152
67 X 1.6 X 2/3	62067203
67 X 1.6 X 3/4	62067304
67 X 1.6 X 3/4 WS	62167304
80 X 1.6 X 0.75/1.25	62080071
80 X 1.6 X 1.1/1.6	62080116
80 X 1.6 X 1.5/2	62080152
80 X 1.6 X 2/3	62080203

For example blade length of 8230mm of 34 X 1.1 X 5/8 Part No. would be 62034508-8230

# Bandsaw Blades

## Bi-alfa Profile

The EXCISION bi-alfa Profile and Profile WS (Wide Set) band saw blade provides outstanding performance on vibration-susceptible cuts. Vibration during cutting of tubes, beams and profiles is often damaging to a conventional band saw blade, which lowers blade life and cut area considerably. For these demanding applications; EXCISION offers the perfect solution with Profile and Profile WS! The reinforced back edge of the tooth increases the overall strength of the tooth to withstand vibrations during interrupted cutting and protects the band saw blade against tooth strippage. The tooth tip consists of proven HSS M42, which has good mechanical features. Bi-alfa Profile is the band saw blade giving the best results when cutting round and square tubes as well as beams.

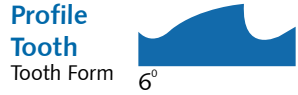

The profile tooth withstands vibrations during cutting of beams and tubes due to the reinforced tooth shape. This effect is intensified by the reduced cutting angle of  $6^\circ$ .

### The Profile WS (Wide Set)

Bi-alfa Profile WS has been specially developed for cutting profiles and beams, which are under tension. During the cutting operation this stress is relieved and thus requires a particularly large kerf in order to prevent the blade from binding in the cutting channel.



### Application areas

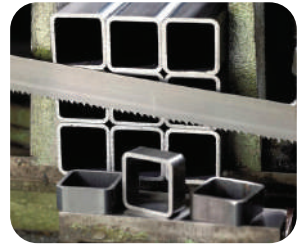

SIZE	CODE
13 X 0.6 X 8/11	62513811
20 X 0.9 X 12/16	625201216
20 X 0.9 X 8/11	62520811
27 X 0.9 X 12/16	625271216
27 X 0.9 X 3/4	62527304
27 X 0.9 X 4/6	62527406
27 X 0.9 X 5/7	62527507
27 X 0.9 X 7/9	62527709
27 X 0.9 X 8/11	62527811
34 X 1.1 X 3/4	62534304
34 X 1.1 X 3/4 WS	62634304
34 X 1.1 X 4/6	62534406
34 X 1.3 X 4/6 COATED	62534406C
34 X 1.1 X 5/7	62534507
34 X 0.9 X 8/11	62534811
41 X 1.3 X 2/3	62541203

SIZE	CODE
41 X 1.3 X 3/4	62541304
41 X 1.3 X 3/4 COATED	62541304C
41 X 1.3 X 3/4 WS	62641304
41 X 1.3 X 4/6	62541406
41 X 1.3 X 4/6 COATED	62541406C
41 X 1.3 X 5/7	62541507
54 X 1.6 X 2/3 WS	62654203
54 X 1.6 X 3/4 WS	62654304
54 X 1.6 X 3/4	62554304
54 X 1.6 X 3/4 COATED	62554304C
54 X 1.3 X 3/4	625543304
54 X 1.6 X 4/6	62554406
67 X 1.6 X 2/3 WS	62667203
67 X 1.6 X 3/4	62667304
67 X 1.6 X 3/4 WS	62667304
67 X 1.6 X 4/6 WS	62667406





# Bandsaw Blades

## Bi-alfa WS Alu

The EXCISION bi-alfa cobalt WS (Wide Set) ALU band saw blade features a wide kerf and an aggressive cutting angle. This facilitates a more efficient chip flow, reduces binding and clogging and promotes longer blade life for all non-ferrous metals.



SIZE	CODE
13 X 0.9 X 3 ALU	62213003

The hook tooth has a positive cutting angle of 10°. This tooth form is particularly suitable for cutting solid, thick-walled tubes and all higher-grade alloy material.

### Application areas



### Hook Tooth



10°

## Bi-alfa RP

The EXCISION bi-alfa cobalt RP band saw blade is produced with HSS-M42 cutting tips. The cutting angle of 16° offers a more aggressive cutting performance. Improving chip flow, ensuring a smooth cut with enhanced blade life.

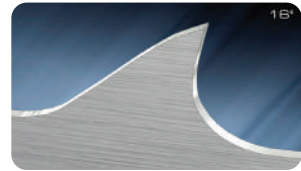

The RP tooth has a positive cutting angle of 16°. Due to its aggressive cutting characteristics, it is most suitable for cutting high-end and exotic alloys and for non-ferrous metals.

SIZE	CODE
41 x 1.3 x 2/3	63441203
67 x 1.6 x 1.1/1.6	63467116
67 x 1.6 x 1.5/2	63467152

### RP Tooth



16°



### Application areas



# Bandsaw Blades

## Bi-alfa Cobalt Extreme

The EXCISION bi-alfa cobalt extreme bandsaw M51 band saw blade has an alloyed steel backing with high chromium content together with a HSSCo-M51 (contains 12% cobalt) cutting edge. Due to the cobalt and tungsten content of the cutting tips, the blade has high thermal and mechanical wear resistance.



### Hook Tooth

Tooth Form



10°

The hook tooth has a positive cutting angle of 10°. This tooth form is particularly suitable for cutting solid, thick-walled tubes and all higher-grade alloy material.



SIZE	CODE
27 X 0.9 X 2/3	64527203
27 X 0.9 X 3/4	64527304
27 X 0.9 X 4/5	64527405
27 X 0.9 X 4/6	64527406
34 X 1.1 X 2/3	64534203
34 X 1.1 X 3/4	64534304
34 X 1.1 X 4/6	64534406
41 X 1.3 X 1.5/2	64541152
41 X 1.3 X 2/3	64541203
41 X 1.3 X 3/4	64541304
41 X 1.3 X 4/6	64541406
54 X 1.6 X 1.5/2	64554152
54 X 1.6 X 2/3	64554203
67 X 1.6 X 1.1/1.6	64567116
67 X 1.6 X 1.5/2	64567152

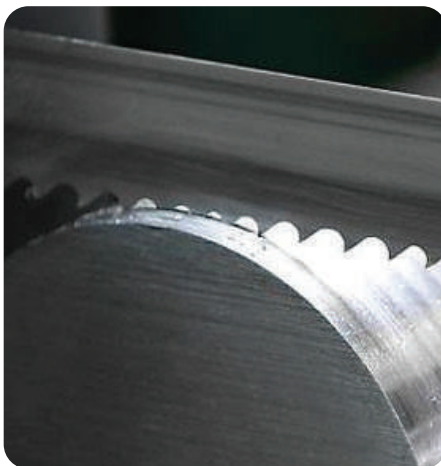

### Application areas



Want to increase blade life?

Use Excision Swarf Brushes, refer to page - 30



**Swarf Brushes**

# Bandsaw Blades

## **Bi-alfa Cobalt** **Master Supreme**

The most premium bimetal blade available.

High-alloyed materials are extremely demanding on all cutting tools. The EXCISION Master Supreme provides a cost effective solution for these difficult applications. M51 cutting tips together with a special tooth geometry provides the perfect solution for high alloyed and exotic materials.

Master Supreme is especially suited to cut large cross sections, therefore it is the ideal solution for steel service centers and forges.

### Excision Master Supreme

Precise perpendicular cut with excellent surface finish on the most difficult-to-cut-materials. The doubled-sided chamfered pre-cutter ensures absolute straight cutting, while a pair of lower set finishing teeth keep the cutting channel open. Resulting in a clean and smooth cutting surface.

### High Efficiency

HSSCo-M51 tooth tips allow to cut materials with a hardness of up to 50 HRc (1600 N/mm<sup>2</sup>). Together with an aggressive cutting angle of 16°, it is the ideal combination to cut high alloyed and exotic materials on larger cross sections.

### Longer Blade Life

The high heat and mechanical wear resistance of HSSCo-M51 cutting tips ensure excellent blade life, when cutting high alloyed and exotic materials.

SIZE	CODE
34 X 1.1 X 2/3	65034203
34 X 1.1 X 3/4	65034304
41 X 1.3 X 1.5/2	65041152
41 X 1.3 X 2/3	65041203
54 X 1.3 X 1.1/1.6	65054116
54 X 1.3 X 1.5/2	65054152

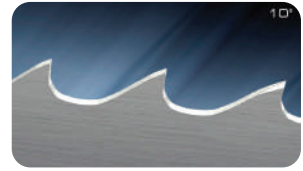

### Master Tooth

Tooth Form

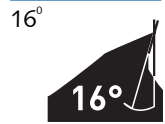

This special development consists of ground tooth tips: chamfered pre-cutter and lower finishing tooth tips. The Master-Tooth is particularly suitable for cutting rare and exceptional alloys.



### Application areas



SIZE	CODE
54 X 1.6 X 2/3	65054203
67 X 1.6 X 0.75/1.25	65067071
67 X 1.6 X 1.1/1.6	65067116
67 X 1.6 X 1.5/2	65067152
67 X 1.6 X 2/3	65067203

# Bandsaw Blades

## HM-Titan Alu TCT

The high performance band saw blade EXCISION HM-Titan ALU is designed for cutting non-ferrous metals, especially aluminum. It is the best blade for cutting slabs and plates. Due to improved bending fatigue strength of the high-alloyed backing strip, the band saw blade withstands the extreme blade speeds and feeds during these cutting applications and therefore offers a high productivity and blade life. The unique tooth geometry satisfies even the highest demands with regard to the surface finish.



**HookTooth**  
Tooth Form



SIZE	CODE
34 X 1.1 X 2/3	68034203
41 X 1.3 X 1.1/1.6	68041116
41 X 1.3 X 1.5/2	68041152
41 X 1.3 X 2/3	68041203
54 X 1.6 X 1.1/1.6	68054116
54 X 1.6 X 1.5/2	68054152
67 X 1.6 X 1.1/1.6	68067116



### Application areas



## HM-Titan B0° TCT

The high-performance EXCISION HM-Titan B0° carbide tipped band saw blade has been designed to cut hardened and tempered or induction-hardened materials with a hardness higher than 50 HRC. Perfect for cutting induction hardened bar.

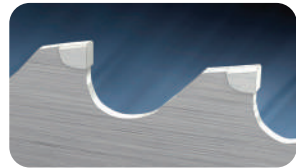

**Normal Tooth**  
Tooth Form

SIZE	CODE
27 X 1.1 X 3/4 B0°	67527304
34 X 1.1 X 2/3 B0°	67534203
34 X 1.1 X 3/4 B0°	67534304
41 X 1.3 X 1.5/2 B0°	67541152
41 X 1.3 X 2/3 B0°	67541203
41 X 1.3 X 3/4 B0°	67541304
54 X 1.6 X 2/3 B0°	67554203

### Application areas

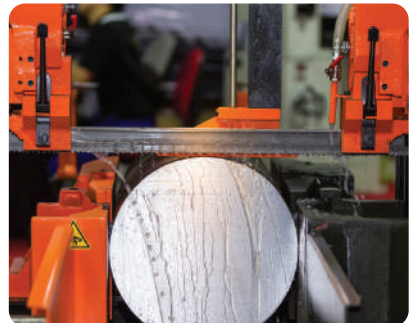

# Bandsaw Blades

## **HM-Titan MU TCT**

The high performance band saw blade Excision HM-Titan MU was developed to cut a variety of different materials. The special designed tooth geometry enables a better chip separation with low noise and high cutting rates. Reduced cutting times combined with an excellent finish are ensured.



**Hook Tooth**  
Tooth Form



SIZE	CODE
27 X 0.9 X 3/4	68527304
34 X 1.1 X 2/3	68534203
34 X 1.1 X 3/4	68534304
41 X 1.1 X 1.5/2	68541152
41 X 1.1 X 2/3	68541203
41 X 1.1 X 3/4	68541304
54 X 1.6 X 1.1/1.6	68554116
54 X 1.6 X 1.5/2	68554152
54 X 1.6 X 2/3	68554203
54 X 1.6 X 3/4	68554304
67 X 1.6 X 1.1/1.6	68567116
67 X 1.6 X 1.5/2	68567152
80 X 1.6 X 1.1/1.6	68580116

### Application areas



Did you know that blade tension solves 90% of all Bandsaw Blade Problems? Check your tension with our new gauge - Page 30



### Blade Tension Gauge

# Bandsaw Blades

## Carbide Grit

The Excision Grit band saw blade is coated with a high quantity of multi-faceted carbide grains, galvanized on a highly flexible backing strip.

The facets of the grains create an extreme number of cutting edges, giving a smooth surface finish. Excision offers a variety of different grain sizes and blade dimensions.

The high-performance EXCISION Carbide Grit blades are ideal for applications that do not form a regular chip



**Grit Tooth**  
Tooth Form



SIZE	CODE
6 X 0.5 X Gulleted	67006000
10 X 0.6 X Gulleted	67010000
13 X 0.6 X Gulleted	67013000
20 X 0.8 X Gulleted	67020000
27 X 0.9 X Gulleted	67027000
32 X 1.1 X Gulleted	67032000

SIZE	CODE
6 X 0.5 X Continuous	67106000
10 X 0.6 X Continuous	67110000
13 X 0.6 X Continuous	67113000
20 X 0.8 X Continuous	67120000
27 X 0.9 X Continuous	67127000
32 X 1.1 X Continuous	67132000

### Application areas

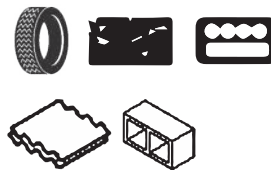



# Bandsaw Blades

## Diamond Grit

The Excision Carbides Diamond Grit Band Saw Blades bring productivity to a new level. These blades are ideal for cutting hard, abrasive and brittle materials and for applications that demand greater precision and closer control.

The Excision Diamond Grit Band Saw Blades are available in a wide range of sizes and in continuous, gulletted, segmented and 4TPI profiles to suit many applications and machine sizes. Alternative grit sizes are available to special order. The 4TPI diamond blade features a positive rake for fast cutting speeds. In challenging applications this blade will typically last longer than traditional toothed blades and provide a consistently smooth finish.



SIZE	CODE
Continuous 20 X 0.9	69020000
Continuous 34 X 1.1	69034000
Gulletted 20 X 0.9	69220000
Gulletted 27 X 1.1	69227000
Gulletted 34 X 1.1	69234000



### Application areas

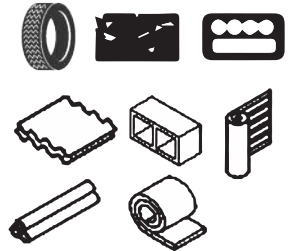

Continuous



Gulletted



# Bandsaw Blades

## Carbon Flexback Carbon Bandsaw

Bandsaw produced from a unique carbon steel for superior cutting performance, improved fatigue resistance and tougher, harder teeth. Carbon bandsaw is available for a wide variety of applications such as Flexback for secondary wood processing, production or high output environments and for straighter cutting and higher feed rates.

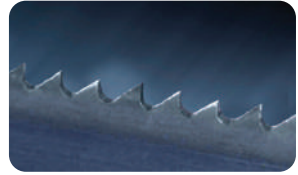

SIZE	CODE
3 X 0.6 X 14	61003014
3 X 0.6 X 18	61003018
5 X 0.6 X 6	61005006
5 X 0.6 X 10	61005010
6 X 0.6 X 4	61006004
6 X 0.6 X 6	61006006
6 X 0.6 X 8	61006008
6 X 0.6 X 10	61006010
6 X 0.6 X 18	61006018
6 X 0.6 X 24	61006024
6 X 0.6 X 32	61006032
8 X 0.6 X 10	61008010
10 X 0.6 X 3	61010003
10 X 0.6 X 4	61010004
10 X 0.6 X 6	61010006
10 X 0.6 X 8	61010008
10 X 0.6 X 10	61010010
10 X 0.6 X 14	61010014
10 X 0.6 X 14	61010014
10 X 0.6 X 18	61010018
10 X 0.6 X 24	61010024
10 X 0.6 X 32	61010032
13 X 0.6 X 3	61013003
13 X 0.6 X 4	61013004
13 X 0.6 X 6	61013006
13 X 0.6 X 8	61013008

SIZE	CODE
13 X 0.6 X 10	61013010
13 X 0.6 X 14	61013014
13 X 0.6 X 18	61013018
13 X 0.6 X 24	61013024
13 X 0.6 X 32	61013032
16 X 0.8 X 3	61016003
16 X 0.8 X 4	61016004
16 X 0.8 X 6	61016006
16 X 0.8 X 8	61016008
16 X 0.8 X 10	61016010
16 X 0.8 X 14	61016014
16 X 0.8 X 18	61016018
16 X 0.8 X 24	61016024
20 X 0.8 X 3	61020003
20 X 0.8 X 4	61020004
20 X 0.8 X 6	61020006
20 X 0.8 X 8	61020008
20 X 0.8 X 10	61020010
20 X 0.8 X 14	61020014
20 X 0.8 X 18	61020018
20 X 0.8 X 24	61020024
27 X 0.9 X 3	61027003
27 X 0.9 X 4	61027004
27 X 0.9 X 6	61027006
27 X 0.9 X 8	61027008
27 X 0.9 X 10	61027010
27 X 0.9 X 14	61027014

### Application areas





# Bandsaw Blades

## Carbon Thin Gauge

Premium Quality Carbon. The high-performance EXCISION Carbon Thin Gauge is for small machines with tight Radius wheels.

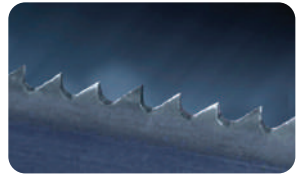

SIZE	CODE
3 X 0.4 X 14TPI	60503014
3 X 0.4 X 18TPI	60503018
6 X 0.4 X 4TPI	60506004
6 X 0.4 X 6TPI	60506006
6 X 0.4 X 10TPI	60506010
6 X 0.4 X 14TPI	60506014
6 X 0.4 X 24TPI	60506024
10 X 0.4 X 4TPI	60510004
10 X 0.4 X 6TPI	60510006
10 X 0.4 X 10TPI	60510010
10 X 0.4 X 14TPI	60510014
10 X 0.4 X 24TPI	60510024
13 X 0.5 X 4TPI	60513004
13 X 0.5 X 6TPI	60513006
13 X 0.5 X 14TPI	60513014
13 X 0.5 X 24TPI	60513024

### Application areas



# Bandsaw Blades

## Carbon Forestry

### Ripper37 Primary Timber Processing Blade

Premium ground tooth primary processing, timber-ripping and resaw applications. Suitable for Wood-Mizer, Baker, Forestor, TimberKing, Woodland Mills, LogMaster, Norwood, Hud-Son, Cook's machines, most portable sawmills and many multi-head sawmilling machines. Optimum depth of tooth hardness allows up to 100% more regrinds. Fully ground tooth profile - Unparalleled "out-of-the-box" performance.



SIZE	CODE
20 X 0.9 X 2	61520002
27 X 0.9 X 2	61527002
27 X 0.9 X 1.3	61527013
34 X 1.1 X 1.1	61534011
41 X 1.1 X 1.1	61541011
54 X 1.1 X 1.1	61554011



### Application areas



Did you know that blade tension solves 90% of all Bandsaw Blade Problems? Check your tension with our new gauge - Page 30



### Blade Tension Gauge

# Bandsaw Blades

## Bi-Alfa Cobalt Forestry

Specialist bandsaw with tooth tips made from high-performance M42 high speed steel and a backing strip in alloy tempered steel. Specialist hard tooth M42 bandsaw for primary timber ripping and resaw applications. Suitable for Woodmizer, Baker, Forester machines, most portable sawmills and many multi-head sawmilling machines.



Hook Tooth

SIZE	CODE
27 X 0.9 X 1	62327001
34 X 0.9 X 1.3	62334013
34 X 1.1 X 1.3	62334113
54 X 1.6 X 1	62354001
54 X 1.1 X 1	623541001

### Application areas



## HM-Titan Timber TCT

The Dependable Precision TCT Timber Blade – Made for the toughest of timbers and available in a large range from 13-54mm wide.

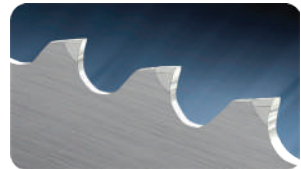

HookTooth  
Tooth Form

The unique geometry ensures:

- Smoothest finish on the timber
- Ability for thin veneer cutting as thin as 0.5mm
- Faster cutting due to chip removal and heat-resistant tips

SIZE	CODE
13 X 0.6 X 3	66013003
13 X 0.8 X 4	66013004
20 X 0.8 X 2	66020002
20 X 0.8 X 3	66020003
27 X 0.9 X 2	66027002
27 X 0.9 X 1.3	66027013
34 X 1.1 X 1	66034001
34 X 1.1 X 2	66034002
54 X 0.9 X 1	66054001

### Application areas



# Bandsaw Blades

## Polished Meat & Fish Food Cutting Bandsaw

Precision ground, hard tooth, bright carbon steel bandsaw for food processing. Razor sharp hook teeth allow maximum penetration, whilst the unique process specific tooth set reduces waste for superior yield.

Available in a wide range of process specific applications such as fresh or frozen meats, frozen fish and carcass splitting.



SIZE	CODE
13 X 0.6 X 3TPI	61213003
13 X 0.6 X 4TPI	61213004
13 X 0.5 X 6TPI	61113006
16 X 0.6 X 3TPI	61216003
16 X 0.6 X 4TPI	61216004
16 X 0.5 X 6TPI	61116006
19 X 0.6 X 3TPI	61219003

### Application areas



# Bandsaw Blades

## Bandknife

Available in a variety of edge types for use in many applications such as baby leaf harvesting, fish filleting, poultry portioning, boneless processed meat and bread slicing plus machine specific use such as Grote and Grasselli. Food bandknives create almost no waste material.

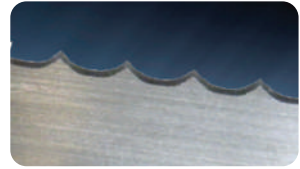

- Superior Yield
- Almost zero product waste
- Razor Sharp Edges
- Improved visual appearance of cut product

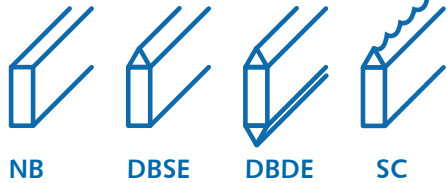

SIZE	CODE
16 X 0.6 NB	6001606
60 X 0.6 NB	6006006
6mm DBSE	6010605
10mm DBSE	6011005
13mm DBSE	6011305
20mm DBSE	6012005
27mm DBSE	6012705
32mm DBSE	6013205
38mm DBSE	6013805
54mm DBSE	6015406
10 X 0.5 DBDE	6021005
13 X 0.5 DBDE	6021305
13 X 0.6 Scallop	6031306
16 X 0.6 Scallop	6031606
20 X 0.5 Scallop	6032005
20 X 0.7 Scallop	6032007
27 X 0.6 Scallop	6032706
27 X 0.7 Scallop	6032707



### Application areas



Razer sharp blades!  
Recommend Excision  
Gloves - Page 30

**Gloves**

# Accessories

## Gloves

Size	Code
EXCISION ULTRA FLEX SAFETY GLOVES - MEDIUM	36000
EXCISION ULTRA FLEX SAFETY GLOVES - LARGE	36001
EXCISION ULTRA FLEX SAFETY GLOVES - EXTRA LARGE	36002
EXCISION LEATHER RIGGER GLOVES CUT 5 - LARGE	36011
EXCISION LEATHER RIGGER GLOVES CUT 5 - EXTRA LARGE	36012
EXCISION EXTENDED CUFF LEATHER RIGGER GLOVES CUT 5 - LARGE	36021
EXCISION EXTENDED CUFF LEATHER RIGGER GLOVES CUT 5 - EXTRA LARGE	36022



Made specially to handle bandsaw blades - Rated to CUT 5. Leather made in Pakistan

## Tension Gauge

The Excision tension meter is the easiest way to measure and check the tension of your bandsaw blade. Calibrating your bandsaw blade tension with ease and precision, will give you optimal blade life whilst not putting your machine at risk of long term damage due to over-tensioning. The tension gauge is designed for bandsaw blades from 6mm to 80mm width and thickness of 0.5mm to 1.6mm

Item	Code
Tension Gauge	8900000030



## Bandsaw Swarf Brushes

Size	Code
90MM PLASTIC WHEEL W/BORE 10MM	699209010
125MM PLASTIC WHEEL W/BORE 12MM	669212512
150MM PLASTIC WHEEL W/BORE 12MM	699215012
80MM WIRE WHEEL W/BORE 8MM	699108008
100MM WIRE WHEEL W/BORE 13MM	699110013
50MM WIRE WHEEL W/SHAFT 6MM	699305006
75MM WIRE WHEEL W/SHAFT 6MM	699307506

Bandsaw Chip/swarf brushes are essential to the longevity and cost-effectiveness of band saws and sawing machines. The swarf brush is responsible for knocking metal swarf out of the teeth on the blade helping increase blade life.



## Magnetic Swarf Remover

Size	Code
400mm	18654
700mm	18655

SAFELY keeps your hands away from sharp pieces of metal. STRONG magnet that attracts large clumps of swarf.



## Magnetic Lifters

Size	Code
250KG	41250 - TML250
500KG	41500 - TML500
1000KG	41700 - TML1000

Amazing new technology of lifting magnets - The lightest most powerful magnets on the market. Can lift steel sheets from 3mm thick.



# Bandsaw Blades

## Metal Cutting Technical Information

### Band Speed for Bimetal

Material	in m/min
Construction Steel / Machining Steel	80 - 90
Case Hardened Steels / Steels for hardening and tempering	45 - 75
Non-Alloy, Tool Steels / Roller Bearing Steels	40 - 60
Alloyed Tool Steels / High Speed Steels	30 - 40
Rust Resistant Steels	20 - 35
Heat Resistant Steels / High Temp, Alloy Steels	15 - 25

For more detailed information or different types of bandsaw blades check out our website: [excision.com.au](http://excision.com.au) or phone us 1800 633 448.

### Bimetal Bandsaw Blade Run In Procedure

The life of an Excision Bi-Alfa bimetal bandsaw blade can be increased significantly by following the recommended running-in procedure. A new saw blade benefits from a short period of cutting at reduced cutting feed rate. Use normal recommended band speed and reduce feed pressure by 50%. After approximately 500cm<sup>2</sup> of cross sectional area or 15 minutes has been sawn, the feed rate should be gradually increased to maximum. The best material to run-in an Excision blade is round mild steel bar, about 80mm diameter, depending on the tooth pitch.

**Highly recommended to increase blade life**

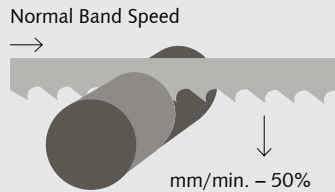

Blade Weld Tester, for a quality weld assurance in every blade.

# Bandsaw Blades

## Metal Cutting Technical Information

### Tooth Selection

For metal cutting bandsaw blades



NORMAL TOOTH (N)



PROFILE TOOTH



TCT TOOTH



SOLIDS

### SOLIDS

#### Vari-Pitch Tothing

Material Diameter (D) mm	Teeth Per Inch
0-5	18
4-8	14
2-15	10/14
8-20	8/12
16-30	6/10
25-40	5/8
35-70	4/6
60-120	3/4
80-200	2/3
120-400	1.5/2
250+	1.1/1.6
400+	0.75/1.25

#### TCT Tothing (Materials over 50 HRc)

Material Diameter (D) mm	Teeth Per Inch
50-120	3/4
100-250	2/3
150-400	1.5/2
350-600	1.1/1.6
500+	0.85/1.15



TUBES AND RHS

### TUBES AND RHS

Tube Width (W)mm	Wall Thickness (T)															
	1	1.6	2	2.5	3	4	5	6	7	8	9	10	12	15	20	50
10	14	10/14	10/14													
20	14	10/14	10/14	10/14	8/12											
25	14	10/14	10/14	10/14	8/12	8/12										
30	14	10/14	10/14	10/14	8/12	8/12	6/10									
40	14	10/14	10/14	10/14	8/12	8/12	6/10	5/8	5/8	5/8						
50	14	10/14	10/14	8/12	8/12	6/10	6/10	5/8	5/8	5/8						
60-120	14	10/14	10/14	8/12	8/12	6/10	6/10	5/8	5/8	4/6	4/6	4/6	3/4	3/4		
130-150		10/14	10/14	8/12	8/12	6/10	6/10	5/8	5/8	4/6	4/6	4/6	4/6	3/4	3/4	3/4
150-180			10/14	8/12	6/10	6/10	5/8	4/6	4/6	4/6	4/6	4/6	4/6	3/4	3/4	3/4
190-300					6/10	6/10	5/8	4/6	4/6	4/6	4/6	4/6	4/6	3/4	3/4	2/3
350-400										4/6	4/6	4/6	3/4	3/4	3/4	2/3
450-500										4/6	4/6	3/4	3/4	3/4	3/4	2/3



# Bandsaw Blades

## Metal Cutting Technical Information

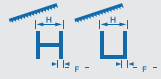
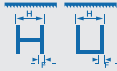

Universal Beam ~ 0° Saw Angle	
BEAM SIZE (H)	WALL THICKNESS (F)
	7 8 9 10 12 14 16 20
150	5/8 4/6 4/6
180	4/6 4/6 4/6
200	3/4 3/4 3/4
250	3/4 3/4 3/4
310	2/3 2/3 2/3
360	2/3 2/3 2/3
410	2/3 2/3 2/3
460	2/3 2/3 2/3
530	2/3 2/3 2/3
610	1.5/2 1.5/2 1.5/2

Universal Beam ~ 5° Saw Angle	
BEAM SIZE (H)	WALL THICKNESS (F)
	7 8 9 10 12 14 16 20
150	6/10 6/10 6/10
180	6/10 6/10 6/10
200	4/6 4/6 4/6
250	4/6 4/6 4/6
310	4/6 4/6 4/6
360	4/6 4/6 4/6
410	4/6 4/6 4/6
460	4/6 4/6 4/6
530	4/6 4/6 4/6
610	3/4 3/4 3/4



### Bundle Cut Tubes and RHS

TUBE WIDTH (W)/MM	WALL THICKNESS (T)															
	1	1.6	2	2.5	3	4	5	6	7	8	9	10	12	15	20	50
10	12/16	8/11	8/11													
20	12/16	8/11	8/11	8/11	8/11											
25	12/16	8/11	8/11	8/11	8/11	8/11										
30	12/16	8/11	8/11	8/11	8/11	5/7	5/7									
40		8/11	8/11	8/11	8/11	5/7	5/7	5/7	4/6	4/6						
50		8/11	8/11	8/11	5/7	5/7	5/7	5/7	4/6	4/6						
60-120		8/11	8/11	8/11	5/7	5/7	5/7	4/6	4/6	4/6	3/4	3/4	3/4	3/4	3/4	
130-150		8/11	8/11	8/11	5/7	5/7	4/6	4/6	4/6	4/6	3/4	3/4	3/4	3/4	2/3	2/3
150-180			8/11	8/11	5/7	5/7	4/6	4/6	4/6	3/4	3/4	3/4	3/4	2/3	2/3	2/3
190-300					5/7	5/7	4/6	4/6	4/6	3/4	3/4	3/4	3/4	2/3	2/3	1.5/2
350-400									4/6	3/4	3/4	3/4	2/3	2/3	2/3	1.5/2
450-500									3/4	3/4	3/4	2/3	2/3	2/3	2/3	1.5/2

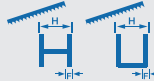
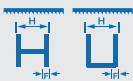

Universal Beam ~ 0° Saw Angle	
BEAM SIZE (H)	WALL THICKNESS (F)
	7 8 9 10 12 14 16 20
150	4/6 4/6 4/6
180	3/4 3/4 3/4
200	3/4 3/4 3/4
250	2/3 2/3 2/3
310	2/3 2/3 2/3
360	2/3 2/3 2/3
410	2/3 2/3 2/3
460	2/3 2/3 2/3
530	1.5/2 1.5/2 1.5/2
610	1.5/2 1.5/2 1.5/2

Universal Beam ~ 5° Saw Angle	
BEAM SIZE (H)	WALL THICKNESS (F)
	7 8 9 10 12 14 16 20
150	5/7 5/7 5/7
180	5/7 5/7 5/7
200	4/6 4/6 4/6
250	4/6 4/6 4/6
310	4/6 4/6 4/6
360	4/6 4/6 4/6
410	4/6 4/6 4/6
460	4/6 4/6 4/6
530	4/6 4/6 4/6
610	3/4 3/4 3/4

# Bandsaw Blades

## Metal Cutting Technical Information

### Sawing Basic Troubleshooting

#### Feed Rate



- a. Feed rate too light.
- b. 'Rubs' the tooth dull.



- a. Feed rate too heavy.
- b. Premature tooth wear.
- c. Teeth wear too fast and break off



- a. Recommended feed rate.
- b. Optimum life

#### Number of Teeth in Band

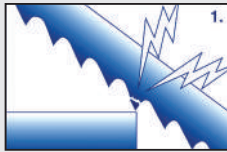

- 1. Too few teeth - tooth straddle (of workpiece) this causes tooth strippage.

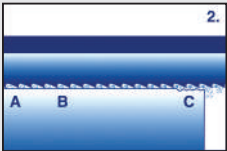

- 2. Too many teeth - chip loading of bandsaw blade gullet, this causes tooth strippage.
  - a. The tooth cuts a chip which fills the gullet
  - b. When the gullet is full, pressure is created.
  - c. When the pressure is not relieved, the results is a crooked cut, stripped teeth or both

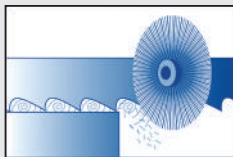

#### BRUSHES

Brushes aid in the cleaning of chips from the gullet of the band. This creates less tendency to strip teeth and creates smoother cut surfaces. Refer to page 30

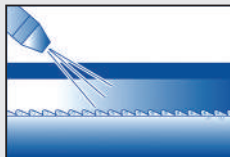

#### COOLANT

Should Wash, Cool, Lubricate the blade as well as the material being cut. We recommend to use XDP 1000 or XDP 2000 - Refer to page 52-53

#### Guide Arms

Guide arms should be as close to the work as possible and secure firmly

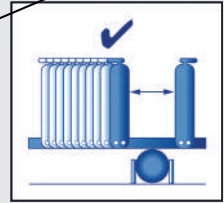
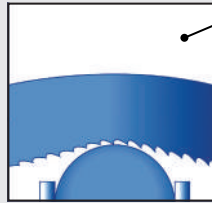
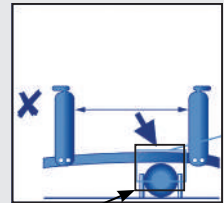
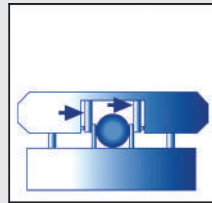

Part number:  
8900000030

#### TENSION

Ensure correct tension. Tension to 300N/mm<sup>2</sup>. A poorly tensioned blade leads to premature wear, blade fatigue and eventual blade breakage. Refer to page 30

# Bandsaw Blades

## Wood Cutting Technical Information

### Blade Width

The blade width is measured from the tooth tip to the back edge of the blade.

Tip: For contour cutting (cutting curves), the blade should be as wide as the machine permits, but still narrow enough so that it can cut the desired shape (radius).

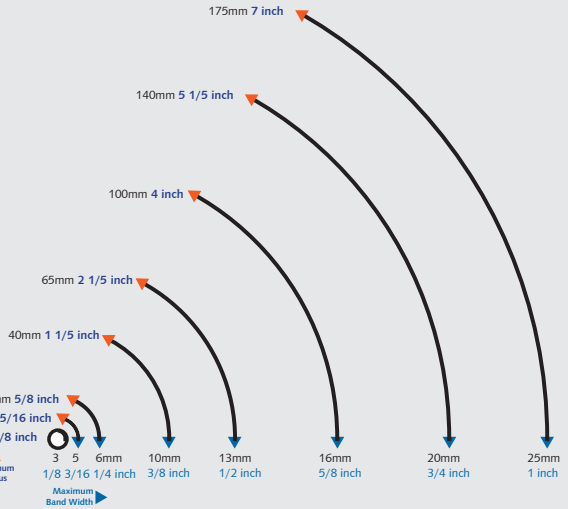

### Teeth Per Inch

The number of teeth per inch (TPI) defines the pitch of the blade and can vary from 1 to 32 TPI. On some bandsaw blades there are different pitches on the same blade referred to as Vari-Pitch

You must select the correct TPI for the thickness of material you are cutting. If the correct TPI is not chosen the blade life will be dramatically reduced.



Teeth Per Inch (TPI)										
24	18	14	10	8	6	4	3	2	1.3	1.1
1	2	2.5	6	10	18	25	38	50	127	

Material Thickness (mm)

### Blade Thickness

Select the blade thickness depending on the wheel size of your machine. See Chart.

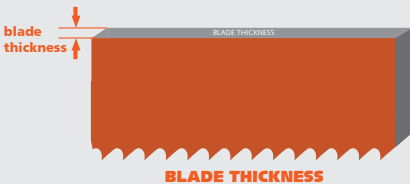

BLADE THICKNESS VS WHEEL DIAMETER	
Blade thickness (mm)	Minimum wheel diameter (mm)
0.36mm	180mm
0.50	250
0.65	325
0.8	400
0.9	450
1.07	535
1.1	550
1.3	650
1.4	700



SCAN TO  
PLAY VIDEO



SCAN TO  
VIEW LINK



## Circular **Blades**





Excision Circular Blades - A range suited for all metal cutting.  
 We manufacture and source coldsaw blades, TCT blades, Cermet blades,  
 Alu TCT blades, GF blades and slitting saws plus much more...



**38-43**

- HSS Cobalt
- Others

Coldsaw Circular Blades



**44**

Cermet Tipped Circular Blades



**45-47**

TCT Circular Blades

- Diamond blades
- TCT Alu blades

E  
T

info@excision.com.au  
 +61 3 5551 4555

**Excision**<sup>®</sup>  
 Dependable Precision

# Circular Blades

## Coldsaw Blades

The circular coldsaw blade is made in Italy from highest quality High Speed Steel – this is the best product used for cutting alloys and common steel. All the blades are made in high-speed steel with a high tungsten and molybdenum content.

- Satisfaction guaranteed
- Long lasting – high wear resistance
- Supplied in quality boxes – will last the life of the blade
- Can be resharpened

Suitable for cutting Mild Steels, Structural Steels, Stainless Steels, Aluminium, Alloys, Copper, Brass. We manufacture blades to suit all coldsaw machines including: Thomas, Brobo, Soco, Hafco, Metalmaster, Steelmaster, MACC and Excision.

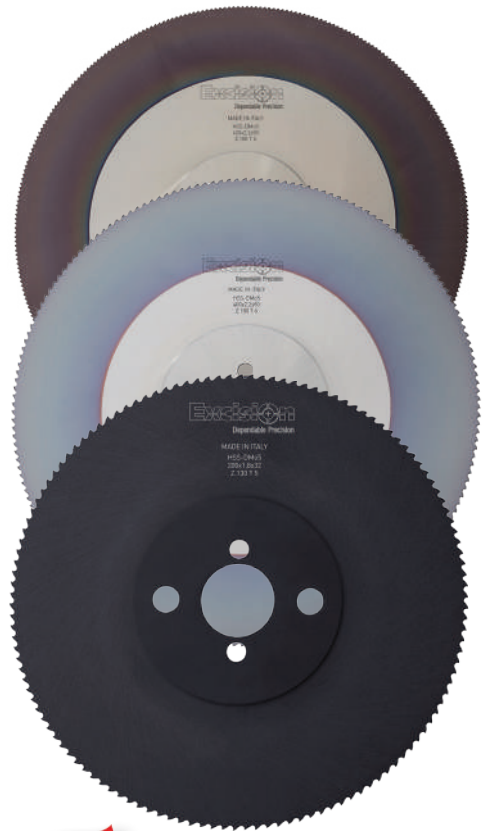

Toothed Blades up to  $\varnothing$  400mm are supplied in quality reusable packaging.

To order simply list the following;

1. Diameter \_\_\_\_\_
  2. Thickness \_\_\_\_\_
  3. Bore \_\_\_\_\_
  4. Number of teeth \_\_\_\_\_
- or we provide a recommendation

For correct tooth selection, refer to page 42 & 43

# Circular Blades

## Coldsaw Blades HSS (DM05)

HSS Coldsaw Blade is the most common used coldsaw blade for cutting Aluminium and Mild Steel. A large range of sizes available for all machines.

This is the standard product used for cutting alloys and common steel. All the blades are made in super high-speed steel with a high tungsten and molybdenum content.

These elements of composition ensure that, after heat treatment, an extremely high hardness and suitable tenacity is achieved. The right tungsten percentage is essential to create the correct quantity of very hard wear-resistant carbides in order to improve the tool life under high temperatures.



Diameter X Bore (mm)	Width X	Code
200 X 2.0 X 32	32	2002032
200 X 2.0 X 40	40	2002040
225 X 2.0 X 32	32	2502032
250 X 1.6 X 32	32	2501632
250 X 2.0 X 32	32	2502032
250 X 2.0 X 40	40	2502040
250 X 2.5 X 25.4	25.4	25025254
250 X 2.5 X 32	32	2502532
250 X 2.5 X 40	40	2502540
275 X 1.6 X 32	32	2751632
275 X 1.6 X 40	40	2751640
275 X 2.0 X 40	40	2752040
275 X 2.5 X 32	32	2752532
275 X 2.5 X 40	40	2752540
275 X 3.0 X 40	40	2753040
300 X 2.0 X 32	32	3002032
300 X 2.0 X 38	38	3002038
300 X 2.0 X 40	40	3002040
300 X 2.5 X 32	32	3002532
300 X 2.5 X 38	38	3002538

Diameter X Bore (mm)	Width X	Code
300 X 2.5 X 40	40	3002540
300 X 3.0 X 40	40	3003040
315 X 2.5 X 32	32	3152532
315 X 2.5 X 40	40	3152540
325 X 2.5 X 40	40	3252540
325 X 3.0 X 40	40	3253040
350 X 2.5 X 32	32	3502532
350 X 2.5 X 40	40	3502540
350 X 3.0 X 32	32	3503032
350 X 3.0 X 40	40	3503040
370 X 3.0 X 32	32	3703032
370 X 3.0 X 50	50	3703050
400 X 3.0 X 40	40	4003040
400 X 3.0 X 50	50	4003050
425 X 3.0 X 40	40	4253040
425 X 3.5 X 40	40	4253540
450 X 3.0 X 40	40	4503040
450 X 3.5 X 40	40	4503540
500 X 4.0 X 40	40	5004040

Toothed blades part number for example HSS (DM05) - 350 x 2.5 x 32 220z would be 3502532220H.

### Application areas



# Circular Blades

## Cobalt Coldsaw Blades HSS-E (Co5%)

HSS-E Coldsaw Blade has a higher content of Cobalt the standard HSS Blades. It has a 5% Cobalt content meaning it is harder and suitable for cutting stainless and hi-tensile tubes.

This is our standard product used for cutting stainless steel and medium hard steel. It is a super high-speed steel that contains all the alloy elements already present in the Dmo5, plus 5% cobalt.

The cobalt does not form carbides, but ensures stability, preventing critical grain enlargement, and above all maintains extreme hardness during working temperatures. This peculiarity is very important when cutting very adherent materials such as stainless steel and very hard metals with high cutting temperatures.



Diameter X Width X Bore (mm)	Code	Diameter X Width X Bore (mm)	Code
250 X 2.0 X 32	2502032C	315 X 2.5 X 32	3152532C
250 X 2.0 X 40	2502040C	315 X 2.5 X 40	3152540C
250 X 2.5 X 32	2502532C	325 X 2.5 X 40	3252540C
250 X 2.5 X 40	2502540C	350 X 2.5 X 32	3502532C
275 X 2.5 X 32	2752532C	350 X 2.5 X 40	3502540C
275 X 2.5 X 40	2752540C	370 X 3.0 X 32	3703032C
300 X 2.5 X 32	3002532C	400 X 3.0 X 40	4003040C
300 X 2.5 X 40	3002540C		

### Application areas





## Circular Blades

### Friction Saw Blades

In our blade range we also offer friction saw blades for cutting pipes and structural shapes. We produce friction saw blades for stationary or flying cutting machines, to cut pipes and profiles in carbon steel. We offer a comprehensive range of dimensions that will fit all the major machines using friction technology, such as: Abbey, Etna, Dreistern, Mannesmann, Oto-Mills, MTM, Vai Seuthe, TRM, and Trennjäger.

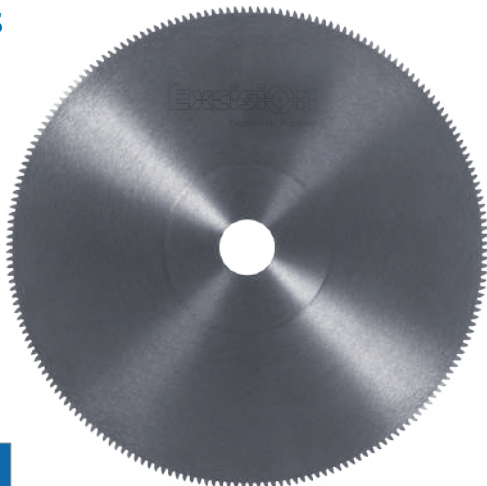

Diameter X Width X Bore (mm)	Teeth	Code
400 X 6.0 X 40	Z = 240	4006040240F
520 X 4.0 X 40	Z = 300	5204040300F
600 X 4.0 X 40	Z = 300	6004040300F

#### Application areas



### Saws for Orbital Tube Cutting

Saws manufactured in HSS-Dmo5 and HSS-Co5 suitable for portable orbital cutting machines. These are built with BW tooth form in order to guarantee the chip evacuation, and are used on tubes with wall thickness between 3 – 5 mm. For cutting stainless steel it is very important to use HSS-Co5 saws, which can offer longer tool life and a better surface. We can also produce these saw blades with P.V.D coating.

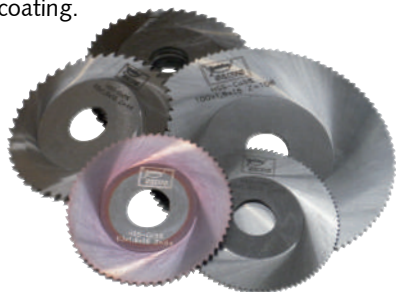

#### Application areas



Diameter X Width X Bore (mm)	Teeth	Code
55 X 0.8 X 13	Z = 80	0550813080C
63 X 1.6 X 16	Z = 64	0631616064C
63 X 1.6 X 16	Z = 72	0631616072C
63 X 1.6 X 16	Z = 96	0631616096C
68 X 1.6 X 16	Z = 44	0681616044C
68 X 1.6 X 16	Z = 72	0681616072C
68 X 1.6 X 16	Z = 84	0681616084C
75 X 1.6 X 16	Z = 44	0751616044C
80 X 1.6 X 16	Z = 84	0801616084C
100 X 1.6 X 16	Z = 40	1001616040C
100 X 1.6 X 16	Z = 108	1001616108C
100 X 2.0 X 16	Z = 44	1002016044C
125 X 1.6 X 16	Z = 120	1251616120C
125 X 1.6 X 22	Z = 128	1251622128C
140 X 1.6 X 16	Z = 150	1401616150C

# Circular Blades

## Coldsaw Blade Technical Information

### Basic Tooth Selection Table

For metal cutting coldsaw blades

Material Diameter Ø	Wall Thickness	Blade Diameter								
		225	250	275	300	315	325	350	370	400
NUMBER OF TEETH										
20-40mm	3.0mm	140	160	160	180	180	200	220	220	240
20-40mm	2.0mm	200	200	220	240	240	260	280	300	340
20-40mm	1.0mm	220	240	260	280	300	320	340	350	380
40-50mm	5.0mm	100	120	140	140	160	160	160	180	180
40-50mm	3.0mm	140	140	160	160	160	160	180	200	200
40-50mm	1.0mm	220	240	260	280	300	320	340	350	380
50-80mm	5.0mm	100	120	120	120	140	160	160	180	180
50-80mm	3.0mm	140	140	160	160	180	180	200	200	220
50-80mm	1.0mm	220	240	260	280	300	320	340	350	380
80-100mm	5.0mm	-	-	120	140	140	140	160	160	160
80-100mm	3.0mm	-	-	160	180	200	200	200	220	220
80-100mm	1.0mm	-	-	260	280	300	300	340	340	360
100-120mm	5.0mm	-	-	-	-	140	140	140	160	160
100-120mm	3.0mm	-	-	-	-	200	200	180	180	180
100-120mm	1.0mm	-	-	-	-	280	300	300	320	340
120-150mm	5.0mm	-	-	-	-	-	-	120	120	140
120-150mm	3.0mm	-	-	-	-	-	-	180	180	180
120-150mm	1.0mm	-	-	-	-	-	-	300	320	340

Material Diameter Ø	Wall Thickness	Blade Diameter								
		225	250	275	300	315	325	350	370	400
NUMBER OF TEETH										
10mm		180	200	220	240	240	240	240	260	280
20mm		160	180	200	200	220	200	200	220	240
30mm		140	140	160	160	180	180	180	200	200
40mm		100	120	140	140	160	160	160	180	180
50mm		80	100	120	120	140	140	140	160	160
60mm		-	-	80	80	100	100	120	140	140

# Circular Blades

## Coldsaw Blade Technical Information

### Pitch Choice

In order to choose the right number of teeth, it is important to consider the section that needs to be cut and the material. The pitch is correct when the teeth to section ratio is at least 1:3 for solid bars and 1:1 for pipes and structural shapes.

Wrong pitch  $S < 3T$

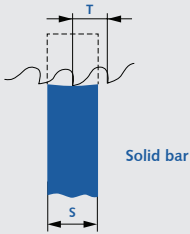

Right pitch  $S > 3T$

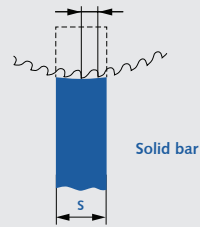

Wrong pitch  $2S < T$

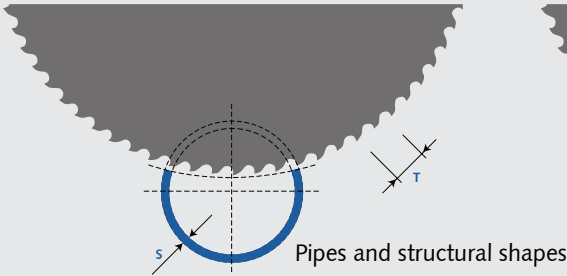

Right pitch  $2S > T$

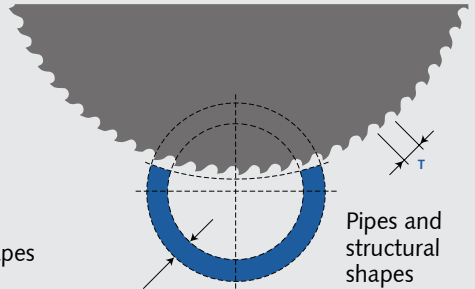

# Circular Blades

## Cermet-Tipped Blades

High quality Cermet circular saw blades, used for cutting solid material, mild and low carbon steels on stationary machines.

This is the right cutting tool for machines: Tsune, Amada, RSA, Rattunde, Everising, Kasto. Saw bodies made using only the best steel from European and Japanese factories.



Diameter X Width X Bore(mm) X Teeth	Code
285 x 2,0/1,6 x 32 x 80Z	2852016032080TCT
460 x 2,7/2,25 x 50 x 60Z	4602722550060TCT
460 x 2,7/2,25 x 50 x 80Z	4602722550080TCT
460 x 2,7/2,25 x 50 x 100Z	4602722550100TCT
750 x 2,7/2,25 x 50 x 60Z	7502722550060TCT
750 x 2,7/2,25 x 50 x 80Z	7502722550080TCT
750 x 2,7/2,25 x 50 x 100Z	7502722550100TCT

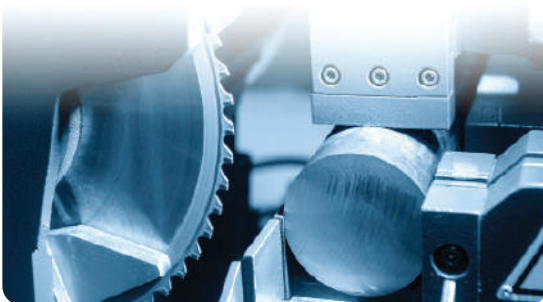

### Application areas



# Circular Blades

## TCT Aluminium Blades

Excision produces Carbide tipped circular saw blades to cut light alloys such as aluminium, zinc, copper, brass and bronze. The tooth geometry is trapezoidal with a negative or positive cutting angle. Thanks to our special teeth geometry and the noiseless system we can also reduce vibration, resulting in an excellent surface finish. All these blades can be used on automatic and manual sawing machines, for cutting tubes, profiles for window frames, and solid materials.



- Suitable for portable and stationary machines
- Variety of non-ferrous metals profiles & tubes
- Excision's Blades have a unique tooth geometry, enabling easy cutting and longer life

### Negative Hook Angle

Negative hook angle for cutting Aluminum profiles and all plastics



#### Application areas

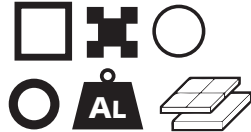

Diameter X Width X Bore (mm) X Teeth	Code
250 X 3.2/2.5 X 30 X 60T	5242503060
300 X 3.2/2.5 X 30 X 96T	5243003096
350 X 3.3/2.8 X 32 X 84T	5243503284
350 X 3.3/2.8 X 32 X 96T	5243503296
350 X 3.3/2.8 X 30 X 108T	5243503108
350 X 3.3/2.8 X 30 X 96T	5243503096
350 X 3.3/2.8 X 32 X 96T	5243503296
380 X 3.8/3.2 X 32 X 110T	52438032110
400 X 4.0/3.2 X 30 X 120T	52440030120
420 X 4.0/3.2 X 30 X 96T	5244203096
500 X 4.2/3.6 X 30 X 120T	52450030120

### Positive Hook Angle

Positive hook angle for cutting solid Aluminum and all plastics



#### Application areas

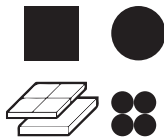

Diameter X Width X Bore (mm) X Teeth	Code
300 X 3.2/2.5 X 30 X 48T	5213003048
355 X 3.0/2.55 X 30 X 120T	52135530120
500 X 2.8/2.2 X 30 X 120T	52150030120
520 X 4.4/3.6 X 30 X 60T	52152030060
600 X 4.6/4.0 X 30 X 140T	52160030140



Aluminium Lube Stick is a wax-like lubricant that can be applied to the cutting edge to prevent aluminium swarf sticking to the blade.

#### XDP Alube



For oil or wax to increase blade life - refer to page 49-69

# Circular Blades

## TCT Dry Cut Blades

Specifically engineered to easily cut through a wide variety of ferrous and other metals  
Low Noise and Resharpenable.

For use without coolant and low sparking  
Blades have a unique tooth geometry, enabling easy cutting and longer life

Materials these blades cut:  
Pipes, threaded rods, profiles, corrugated and trapezoidal sheets, wireducts, sandwich panels, dry mortarless construction profiles, fastening profiles (DIN rails), grates using dry cutting method.

Machine these blades suit:  
Evolution, Jepson, Ridgid, Slugger(Fein), Dewalt, Makita, Milwaukee, Trademaster, etc.



Diameter X Width X Bore (mm) X Teeth	Code
100 X 1.6/1.2 X 16 X 20T	5111001620
100 X 1.6/1.2 X 20 X 20T	5111002020
140 X 1.8/1.35 X 62 X 46T	5111406246
182 X 2.2/1.6 X 20 X 34T	5111822034
185 X 2.2/1.6 X 20 X 48T	5111822048
200 X 2.2/1.8 X 30 X 40T	5112003040
230 X 2.2/1.8 X 30 X 44T	5112303044
250 X 2.2/1.8 X 30 X 54T	5112503054
305 X 2.2/1.8 X 25.4 X 60T	5113052560
305 X 2.2/1.8 X 25.4 X 80T	5113052580
305 X 2.2/1.8 X 30 X 60T	5113053060
355 X 2.4/2.0 X 25.4 X 72T	5113552572
355 X 2.4/2.0 X 25.4 X 90T	5113552590
355 X 2.4/2.0 X 30 X 90T	5113553090

### Application areas

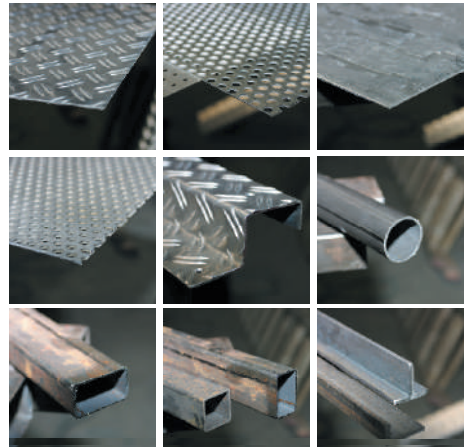



# Circular Blades

## TCT Stainless

The Excision TCT Stainless blade is made from new unique carbide that allows longevity and improved cutting quality in all metals and especially stainless steels.

Smooth cutting of tubes, sheets, profiles and solid materials made of stainless steel, construction site steels and any kind of non-ferrous such as Aluminium or copper. Examples: stainless steel or copper tubes for sanitary usage, construction site square pipes, reinforcing steel, angle irons, corrugated sheets etc.

No other non-coated carbide tipped saw blade can cut such a wide range of materials, smoothly and for a long time.



Diameter X Width X Bore (mm) X Teeth	Code
250 X 2.2/1.8 X 25.4 X 60T	5152502560
305 X 2.2/1.8 X 25.4 X 72T	5153052572
355 X 2.4/2.0 X 25.4 X 84T	5153552584

### Application areas

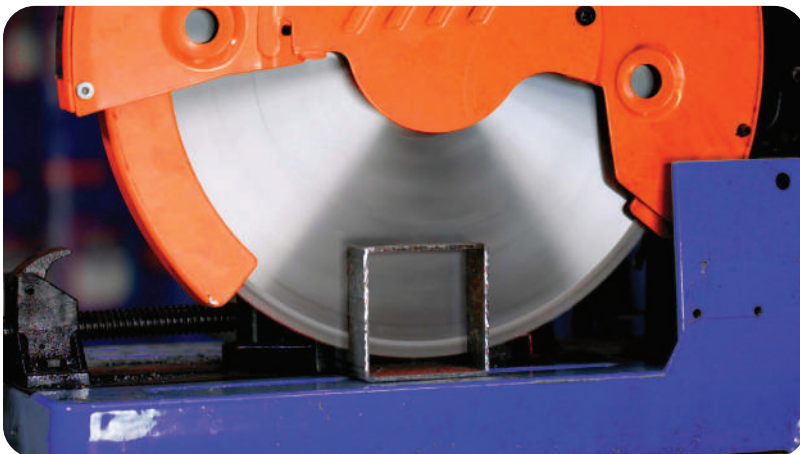
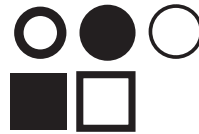



SCAN TO  
PLAY VIDEO



SCAN TO  
VIEW LINK



# Metal Working **Fluids**

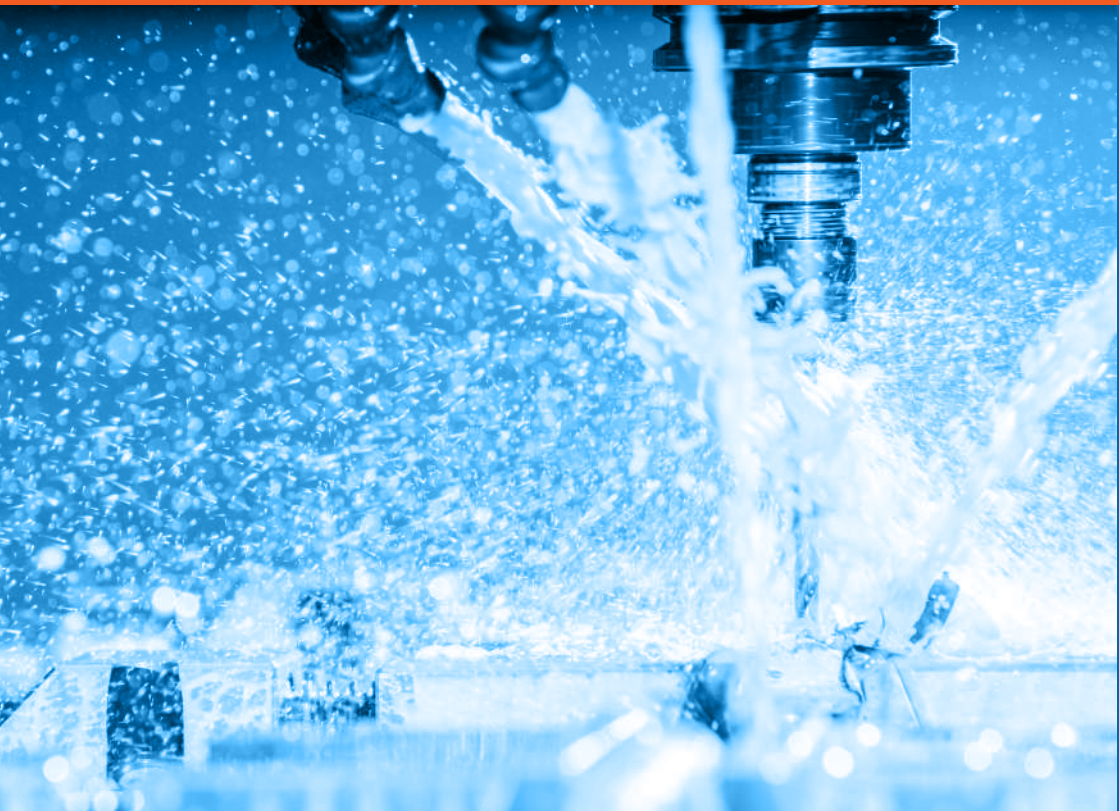





Excision is a manufacturer of high quality metal working fluids for all applications. We manufacture soluble oils to neat cutting oils and also supply other metalworking fluids such as slideway oil and hydraulic oils.



## 52-56

Coolants



## 57-65

Neat Oils



## 66-69

Industrial Fluids

# Metal Working Fluids

## Coolant Comparison Table

Legend: ★★ ★★ Best ★★ Better ★ Good □ Not Applicable

		Coolant Type				
		XDP1000	XDP2000	XDP3000	XDP3500	XDP4500
	Type	Soluble	Semi-Synthetic	Synthetic	Synthetic	Synthetic
Application	Cutting	★★★	★★★	★★		
	Drilling	★★★	★★★	★★		
	Machining	★★★	★★★	★★		
	Grinding	★	★★	★★★		
	Cobalt Grinding				★★★	
	Plasma					★★★
Metals	Aluminium	★★★	★★	★	★	
	Steel	★★	★★★	★★★	★★★	
	Yellow Metals	★★★	★★	★	★	

## Neat Oil Comparison Table

		Neat Oil Type							
		XDP118	XDP120	XDP135	XDP605	XDP900	XDP905 Fluid	XDP905 Spray	XDP905 Foam
Application	Drilling	★★	★★★	★	★	★★★	★★★	★★★	★★★
	Machining	★★	★★★	★	★	★★★	★★★	★★★	★★★
	Grinding	★★	★★★	★★	★★★	★★★	★	★★	★
Pump	MQL (Misting)	★★★	★★★						
	Spray	★★	★★	★★★	★★★	★★	★		
	Flood			★★	★★★	★★★	★★		
Metals	Aluminium	★★★	★★★	★★★	★★★	★★★	★★★	★★★	★★★
	Steel	★★★	★★★	★★	★★★	★★★	★★★	★★★	★★★
	Yellow Metals	★★★	★★★	★★	★★★		★★★	★★★	★★

# Metal Working Fluids

## Dependable Metal Working Fluids

The Excision 1L system

A unique concept developed to save money, time and wastage

1 Litre pouch of coolant that is pre-measured, so all you have to do is add to 20 litres of water



**MINERAL**  
**XDP 1000**  
Water Soluble Cutting Fluids

An economical coolant for use in a wide range of ferrous and non-ferrous metals.



**SEMI-SYNTHETIC**  
**XDP 2000**  
Water Soluble Cutting Fluids

An enhanced coolant developed from a formula to extend tool life.



# Metal Working Fluids

## XDP1000 Mineral Coolant

Soluble concentrate for general machining

XDP1000 is a water-miscible cutting fluid with high lubricating and cooling properties based on refined mineral oil and anti-wear and anti-oxidant additives. Thanks to its high oil content, it obtains a very good surface finish of parts and a long life of the tool.

XDP1000 is a cutting fluid that is suitable for machining metals such as steel, copper, brass and their alloys. It can be used in a wide range of water hardness between 50 and 500 ppm CaCO<sub>3</sub>. XDP1000 is a soluble oil free from chlorinated derivatives, boron, amines, nitrites or Sulphur's.

### Benefits:

- Good corrosion and oxidation protection properties,
- High bio-stability giving a long life emulsion stability
- Better cooling and lubricating capacity
- Efficient chip removal

### Application:

XDP1000 is a concentrate which must be diluted in water with hardness between 50 to 500 ppm of CaCO<sub>3</sub>. Concentrate has to be added to water and not vice versa. The application concentration could be between 5% to 6% for light duty operations and between 8% to 10% for heavy duty operations.



Size	Code
1 Lt x 10 pk	81110-10
5 Lt	81110-5
20 Lt	81110-20
205 Lt	81110-205



SCAN TO VIEW  
DATA SHEET



## XDP2000 Semi-Synthetic Coolant

Semi-synthetic fluid for metal machining

XDP2000 is a semi-synthetic cutting fluid with high stability, designed for excellent surface finishes on ferrous metals, aluminium and aluminium alloys. It works specially where water is soft or with medium hardness. Once diluted disperses in nano-globules avoiding coalescence, depositions and other imperfections of the classic emulsions.

XDP2000 meets the latest technological advances in cutting solutions. Contains no secondary amines, nitrites, halogenated derivatives or any other substance that may adversely affect both health and the environment.

### Benefits:

- It has excellent sump life.
- Greater cooling power,
- Increased resistance to foreign oils,
- Lower drag-out
- High emulsion stability in soft or medium hard water,
- High power corrosion inhibitor,
- High lubricating effect,
- Efficient chip removal
- Reject hydraulic and tramp oil



### Application:

XDP2000 is dispersed in water by adding the concentrate to the water until the minimum of 4% and the maximum of 12%. The ideal concentration must be determined according to the complexity of the operation and water hardness: The product will be used for machining aluminium and ferrous alloys which intended to minimize the drag of coolant per piece.



Size	Code
1 Lt x 10 pk	81210-10
5 Lt	81210-5
20 Lt	81210-20
205 Lt	81210-205



# Metal Working Fluids

## XDP3000 Synthetic Coolant

Synthetic coolant for metal machining and grinding

XDP3000 is a synthetic fluid free from mineral oil, designed to obtain excellent surface finishing in aluminium alloys, steel and cast iron. XDP3000 is based on the latest technology and allows minimum consumption together with long sump life. It does not contain secondary amines, nitrites, halogenated derivatives and hard metals.



### Benefits:

- Highest cooling power
- Very low drag-out
- Excellent stability in a wide range of water hardness
- High detergency

### Application:

XDP3000 is indicated for water hardness of 50 to 600 ppm of CaCO<sub>3</sub>. The product has to be mixed with water by pouring it onto the water at a minimum concentration of 4%, to be adjusted depending on the severity of the operation. The product is recommended for machining of ferrous and aluminium alloys, where a minimum carry-over is expected, and for grinding.



SCAN TO VIEW  
DATA SHEET



Size	Code
5Lt	81310-5
20Lt	81310-20
205Lt	81310-205

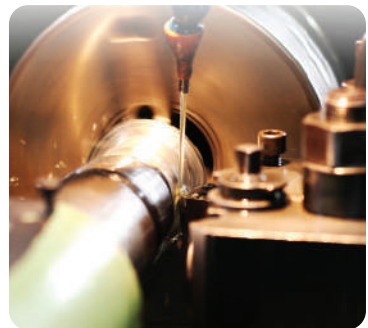



# Metal Working Fluids

## XDP3500 Synthetic Coolant

Synthetic fluid for carbide grinding and metal machining

XDP3500 is a water-soluble synthetic metalworking fluid free from mineral oil for machining and grinding hard metals. It's stable and transparent with high antioxidant power. The product is studied especially for excellent finishes in machining operations and grinding tools, dies and carbide parts containing tungsten, carbide, copper, cobalt etc. XDP3500 doesn't emulsify tramp oils.



### Benefits:

- Good antioxidant properties
- Does not cause leaching of cobalt
- Rejects foreign oils
- Gives better cooling effect
- Gives better lubrication without leaving oily residues



### Application:

Add XDP3500 to water shaking slightly. Water hardness must not exceed 400ppm. As a general rule and normal grinding operations, concentration of employment is 3% to 6%.



SCAN TO VIEW DATA SHEET



Size	Code
5Lt	81350-5
20Lt	81350-20
205Lt	81350-205



# Metal Working Fluids

## XDP4500 Plasma Protector

Synthetic water-miscible plasma protector

XDP4500 is a synthetic fluid free from mineral oil, designed to effectively protect plasma cutting water tables. XDP4500 prevents oxidation from occurring in the water table and is highly effective against microorganisms of watery systems. Does not contain secondary amines, nitrites, halogenated derivatives and hard metals.



### Benefits:

- Highest cooling power
- Strong anti-bacterial effect
- Effective corrosion prevention
- Excellent stability in a wide range of water hardness
- Odourless
- Easy to clean



### Application:

XDP4500 is to be mixed with water at a concentration between 5 and 10%. It is recommended for protection of plasma cutting water tables.



SCAN TO VIEW  
DATA SHEET



Size	Code
5Lt	81445-5
20Lt	81445-20
205Lt	81445-205

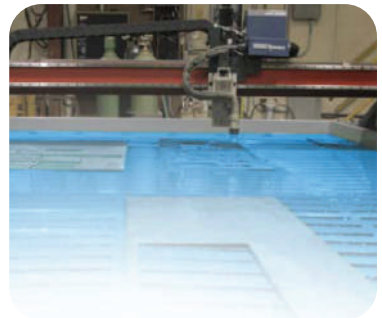



# Metal Working Fluids



Revolutionise how you do Cutting, Drilling and Tapping or use lubrication in high pressure applications. XDP 905 - high performance Paste and Oil in easy to use applicators make any job easier ensuring you get up to 5 times tooling life.

## XDP905 Range

### XDP905 Spray Easy Spray Application

XDP905 Spray is a high performance neat oil for medium and severe cutting operations (milling, grinding, drilling, tapping, broaching and general cutting on lathes). It's suitable for cutting steel, stainless steel, low and high steel alloys, cast iron, aluminum alloys materials and yellow metals like copper and brass

**Benefits:**

- Low viscosity – ideal for deep boring
- Reduces wear and friction
- Easy application
- Protects against corrosion
- Increases tool life up to 5 times
- Chlorine and heavy metals free technology

Size	Code
400g	84905-300



# Metal Working Fluids

## XDP905 Foam

Ideal for vertical drilling - remains on the cutting tool

XDP 905 Foam is a cutting, drilling and tapping oil that is the ultimate performer in high pressure applications formulated for ferrous and non ferrous metals, great on stainless steel. XDP 905 Foam is a highly formulated semi-synthetic cutting oil - the latest development in extreme pressure cutting and tapping oils. XDP 905 provides exceptional film strength, adhesion to cutting edge, high speed applications, highest resistance to corrosion, and is ideal in deep boring and drilling applications. It is Chlorine and Sulphur free. Contains mineral oil for extra lubricity & low consumption - can therefore be used as minimum quantity lubricant.

### Benefits:

- Foam thoroughly coats cutting tool
- Increases tool life up to 5 times
- Reduces wear and friction
- Protects against corrosion
- High residual lubricant
- Easy application foaming action
- Penetrates deep into the cut
- Promotes a superior finish



Size	Code
440g	85905-440

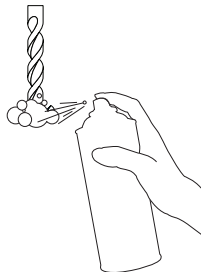

# Metal Working Fluids

## XDP905 Paste

Available in mess-free application brush

XDP905 Paste is a high-performance neat product for medium and severe cutting operations (drilling, tapping, cutting, etc.). It is suitable to machine ferrous and non ferrous metals. XDP 905 Paste provides exceptional film strength, adhesion and extreme pressure properties. It has highest resistance to water and corrosion, and is an excellent anti-seize. It comes in an innovative no-mess tube with a heavy-duty industrial brush attached to it. Simply squeeze the tube and apply the paste mess-free to where it's required. The paste also comes in a traditional tub for easy dipping.



### Benefits:

- Chlorine-free technology
- High performance
- Outstanding tool life
- Reduces wear and friction
- Protects against corrosion



Size	Code
200g Tube	83905-200
500g Tub	83905-500
5kg Tub	83905-5



SCAN TO VIEW  
DATA SHEET



# Metal Working Fluids

## XDP905 Fluid

Neat oil for metal machining

Excision's new XDP 905 Fluid for neat oil application continues the superior performance of the XDP 905 range. XDP905 is a high performance neat oil for medium and severe cutting operations (milling, grinding, drilling, tapping, broaching and general cutting on automatic lathes). It's suitable for cutting steel, stainless steel, low and high steel alloys, cast iron, aluminum alloys materials and yellow metals like copper and brass.

The product is a low mist and low odour formulation with excellent performance due to the presence of Extreme-Pressure additives and very highly refined mineral oils.



### Benefits:

- Low viscosity – ideal for deep boring
- Protects against corrosion
- Reduces wear and friction
- Increases tool life up to 5 times



### Application:

Applying the lubricant when cutting, drilling or tapping has never been easier. Simply point the nozzle of the bottle to the drill or cutting area, give it a slight squeeze and vital lubrication is provided when coolant cannot be applied via coolant systems.

Size	Code
500mL	82905-500
1 Lt	82905-1
5 Lt	82905-5
20 Lt	82905-20





# Metal Working Fluids

## XDP900 Threading & Cutting Oil

Neat oil for metal machining

XDP900 is a high performance neat oil for medium and severe cutting operations. It's suitable for cutting ferrous (middle to high alloyed steel) and non-ferrous materials (Aluminium, copper and brass).

XDP900 belongs to the latest technology that is based in chlorine, active sulphur and heavy metals free additives.

The product is a low mist and low odour formulation with excellent performance due to the presence of Extreme-Pressure additives and very highly refined mineral oils.



### Benefits:

- Chlorine and active sulphur free technology
- High performance
- Improved Tool life
- Low mist formation
- High flashpoint
- Low viscosity



### Application:

XDP900 is a direct use product that needs to be filtered to lengthen its life time. The product can be used either in individual machining centers or in central systems.



Size	Code
5 Lt	82900-5
20 Lt	82900-20
205 Lt	82900-205

# Metal Working Fluids

## XDP135 Neat Machining Oil

Neat oil for metal machining and grinding

XDP135 is a highly refined mineral-based cutting oil designed for medium to heavy duty cutting and grinding operations for ferrous and non-ferrous metals. It can be used specially for cutting, grinding, lapping and honing steel, aluminium and yellow metals without staining and with very low smells.

The select raw materials used in XDP135 provide good environmental conditions with very low mist and smoke in spite of its low viscosity.

Thanks to its anti-wear, extreme-pressure and polar additives, XDP135 has excellent lubrication and cooling properties, ensuring good corrosion protection on workpieces and machine parts.



### Benefits:

- Excellent lubricating & cooling properties
- Easy to clean
- Low mist
- Very good corrosion & oxidation protection
- Mild odour

### Application:

XDP135 is used as supplied, without dilution, for cutting and grinding operations. It is suitable for ferrous and non-ferrous metals, ensuring high performance cutting conditions, good machine protection and low environmental impact.



Size	Code
5Lt	82310-5
20Lt	82310-20
205Lt	82310-205

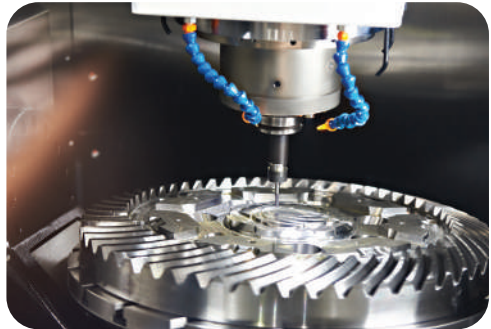

# Metal Working Fluids



## XDP605 Neat Grinding Oil

Neat oil for metal grinding

XDP 605 is a highly refined and hydro-cracked mineral oil designed for soft to medium duty cutting and grinding operations for use on ferrous and non ferrous metals. It can be used for grinding, lapping and honing steel and yellow metals without staining. The contents of XDP 605 allow it to be used in conditions of very low mist and smoke even if the viscosity is low. Its anti-wear and polar additives provides excellent lubrication and cooling. XDP605 is a food grade lubricant H-1 class (with incidental food contact)



### Benefits:

- Doesn't stain any metal,
- Good lubricating and cooling properties
- Easy to clean
- Excellent lubricity and wear protection.
- Free of harmful compounds
- Good protective properties against corrosion and oxidation



### Application:

XDP605 can be used for cutting and grinding operations without dilution. It is suitable for ferrous and non ferrous metals generally and specially cemented carbides including diamond and CBN wheels. Its characteristics allow excellent cutting conditions, high performance, machine efficiency with low environmental impact.

Size	Code
5Lt	82325-5
20Lt	82325-20
205Lt	82325-205

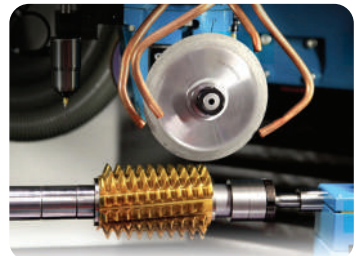

# Metal Working Fluids

## XDP116 Spray Misting Oil

Neat oil for MQL

XDP 116 is a high performance, fully Biodegradable spray misting oil product. Formulated for aluminium cutting applications, it prevents the swarf from sticking to the cutting edge being exceptionally thin and leaving minimal residue.



### Benefits:

- Minimal residue
- Fully Biodegradable
- High Anti-corrosion properties
- Chloride, nitrate, sulphur and silicone free

### Application:

XDP116 is applied as supplied, preferably micro-dosed or sprayed in operations like sawing, milling and drilling of aluminium and its alloys. In general, it's suitable for non-ferrous metals. It's suitable for lubricating operations without chip, deformed or stamped product type.



Size	Code
5Lt	82410-5
20Lt	82410-20
205Lt	82410-205



SCAN TO VIEW  
DATA SHEET







# Metal Working Fluids

## XDP120 Neat Oil

Neat oil for MQL

XDP120 is a neat cutting synthetic oil used specially in the area of minimum quantity lubrication (MQL). It can be used primarily in machining steel, aluminium and aluminium alloys and non-ferrous metals in general.

The product can provide high wear protection to both parts and tools. In addition to a perfect finish, leaves almost no residue on workpieces. It's free of chlorinated compounds.



### Benefits:

- Doesn't stain any metal,
- Low consumption,
- Low Mist at application,
- High oxidation stability,
- Excellent lubricity and wear protection.
- Minimal residual oil content in the chip,
- Biodegradable,
- Improved health and safety conditions.



### Application:

XDP120 is applied as supplied, preferably micro-dosed or sprayed in operations like sawing, milling and drilling of steel, aluminium and its alloys. In general, it's suitable for non-ferrous metals. It's suitable for lubricating operations without chip, deformed or stamped product type.

Size	Code
5Lt	82430-5
20Lt	82430-20
205Lt	82430-205



SCAN TO VIEW  
DATA SHEET



XDP120 is best applied through MQL unit. Refer to page 71



**MQL Micro Lubrication System**

# Metal Working Fluids

## XDP-SW Slideway Oil

Available in ISO 32, 68, 220 grades.

XDP-SW Slideway Oil is an oil based lubricant formulated with highly refined mineral oil and special additives for its use in guides and slides on machines. It contains friction modifiers, extreme-pressure additives and demulsifiers which offer unctuousness and facilitate the separation of the coolants. It can be also used in tool-machines gearboxes and mechanical transmission subjected to very high loads.



### Benefits:

- Very high adhesion on metallic surfaces avoiding noises and vibrations.
- Anti-wear and high extreme-pressure properties to enable its use in gearboxes and mechanical transmission for tool-machines.
- Excellent protection against corrosion and oxidation



Description	Stock Code
XDP-SW32 5 Lt	84132-5
XDP-SW32 20 Lt	84132-20
XDP-SW68 5 Lt	84168-5
XDP-SW68 20 Lt	84168-20
XDP-SW68 205 Lt	84168-205
XDP-SW220 5 Lt	841220-5
XDP-SW220 20 Lt	841220-20



SCAN TO VIEW  
DATA SHEET





# Metal Working Fluids

## XDP-HYD Hydraulic Oil

Available in ISO 32, 46, 68 grades.

XDP-HYD Hydraulic Oil is intended for all hydraulic systems operating at high pressures and are not required to have significant variations in viscosity with temperature. Based on latest generation of high refining paraffins, ZDDP and viscosity improvers. Thus providing high reliability in preventing viscosity falls, oxidation and fluid stability



### Benefits:

- Low wear of valves and pumps
- Easy separation from water
- It protects against corrosion and oxidation
- Good anti-wear components
- It contains extreme-pressure elements



Size	Code
XDP-HYD32 5Lt	82132-5
XDP-HYD32 20Lt	82132-20
XDP-HYD32 205Lt	82132-205
XDP-HYD46 5Lt	82146-5
XDP-HYD46 20Lt	82146-20
XDP-HYD46 205Lt	82146-205
XDP-HYD68 5Lt	82150-5
XDP-HYD68 20Lt	82150-20
XDP-HYD68 205Lt	82150-205



SCAN TO VIEW  
DATA SHEET



# Metal Working Fluids

## XDP825 Punch & Shear Oil

XDP825 is a high performance neat oil for medium and severe punch and shear operations. It's suitable for cutting ferrous (middle to high alloyed steel) and non-ferrous materials (Aluminium, copper and brass). Excellent performance due to the presence of Extreme-Pressure additives and very high refined mineral oils.

Size	Code
500ml	82825-500



## XDP System Cleaner

XDP System Cleaner is a specially designed cleaner to be used in systems where metalworking fluids are continuously circulating. This product removes all dirtiness accumulated in pipes and tanks where metalworking fluids are running. XDP System Cleaner is formulated to clean, disinfect and remove lime or other salt residues formed after long periods of the metalworking fluid circulating inside the pipelines.

### Benefits:

- High cleansing properties.
- Non corrosive properties.
- Compatible with all materials present in metalworking industries



### Applications:

XDP System Cleaner is diluted in water at 3-6% depending on the dirtiness in the system.

The system needs to be completely emptied of normal product. Load inside the system the minimum amount of water that allows the system to be set up in circulation mode and add the corresponding % of XDP System Cleaner to reach the desired concentration. Solution needs to be in recirculation for at least 2 hours and rinsed out with clear water before refilling with fresh product.

If out coming water is not clean, repeat the operation described above until we reach an acceptable level of cleanliness.

Size	Code
500ml	84620-500
1Lt	84620-1





# Metal Working Fluids

## XDP Alube

Size	Code
150 g	84120-150
1 kg	84120-1000

### Aluminum Lube Stick

XDP Aluminium Lube Stick is a wax-like lubricant that can be applied to the cutting edge to prevent aluminium swarf sticking to the blade. It has specially formulated additives to prevent it being eaten by rodents.



## Hand Cleaner

Excision Anti-bacterial hand cleaner is formulated carefully to give you the benefit of excellent cleaning and sanitation, whilst protecting your hands from drying out, as well as providing protection against 99.9% of germs. Contains heavy duty poly beads for cleaning all tough dirt, grime and grease!

### Benefits:

- Formulation for cleaning the toughest grime and grease!
- Powerful Anti-bacterial Action - kills 99.9% of germs
- Trusted robust cleaning & hygiene performance

Size	Code
5Lt	84610-5
20Lt	84610-20
5Lt with Hand Pump	84610-5P
5Lt with Hand Pump	84610-20P



## Hand Wash

Excision Anti-bacterial Hand Wash is formulated carefully to give you the benefit of excellent cleaning and sanitation, whilst protecting your hands from drying out, as well as killing 99.9% of germs.

### Benefits:

- Soothes & nourishes your skin, leaves your skin refreshed & clean
- Powerful Anti-bacterial Action - kills 99.9% germs
- Trusted robust cleaning & hygiene performance

Size	Code
5Lt	84616-5
20Lt	84616-20
5Lt with Hand Pump	84616-5P
20Lt with Hand Pump	84616-20P



# Metal Working Fluids

## XDP Emulsion Mixer

XDP Emulsion Mixer ensures accurate and consistent blending of cutting oils or other liquids, which are to be mixed with water. The mixer is extremely easy to install and operate. The mixer is driven by water pressure only. Just turn on the water supply when re-filling your machines. Also available in a bigger aluminum model with a flow of 2000 l/h



Type	Code
Emulsion Mixer	84610-205M

## XDP Oil Skimmer

This Oil Skimmer removes unwanted tramp oils and other contaminants from the surface of the cooling lubricant. Surface Oil should always be removed, not only to extend the emulsion life, but also to create optimal conditions.

Type	Code
Oil Skimmer	84610-05S



## XDP Rotary Hand Pump

- Solid cast iron construction
- Approx. 3 revolutions per litre
- 3 piece steel suction pipe & 2" Bung Adaptor

Type	Code
Rotary Pump	84610-205P



## XDP Refractometer

The Refractometer is developed for control of the concentration of various industrial fluids. At a recommended oil concentration of 8% –12%, the emulsion will perform both the lubrication and cooling tasks. The oil to water ratio is measured by the EXCISION refractometer and can be read off a scale visible through the eyepiece or on the digital screen.



Type	Code
Digital Refractometer	84610-05DR
Manual Refractometer	84610-05R

# Metal Working Fluids



## Excision MQL Micro Lubrication System

The Excision MQL Micro Lubrication System is an easy bolt-on MQL (Minimum Quantity Lubrication) system that can be fitted to any machine. Quantity and speed of lubrication is easily adjusted to suit your needs. Can be used inside and outside machines. Increases tool life and production time and reduces waste and mess.

### Benefits:

- Extends Tool Life
- Economical and Eco-friendly
- Safer for operators
- Prevents corrosion damage to machinery & steel



### Spray mist unit

Size	Code
MQL 1.5L	8501024V

Different nozzle types available



## Coolant Pumps

A full range of coolant pumps to suit all models and makes. Making sure you have constant flow of coolant is critical.

Size	Code
85mm Leg 240/415V	88140020
115mm Leg 240/415V	88140022
140mm Leg 240/415V	88140025



## Excision Tank Filter XDP 90F 240V

XDP 90F - Filtration system for coolant lubricants, oils and watery solutions. XDP 90F is suitable for all industrial basins. XDP 90F can be placed easily into the tank for fast cleaning: You can clean and filter all of your baths immediately - the patented mechanical micro filtration technology of XDP 90F only needs a couple of minutes. The result is a clean high quality coolant lubricant, oil and watery solution - freed from chips and solids.



Size	Code
90L/min	85590

## 20 LT Drum Including tap in the lid

Empty 20Lt drum with a tap in the lid, perfect for mixing your metalworking fluid solution.

Size	Code
20Lt	20LTDUM





# Magnetic Drills

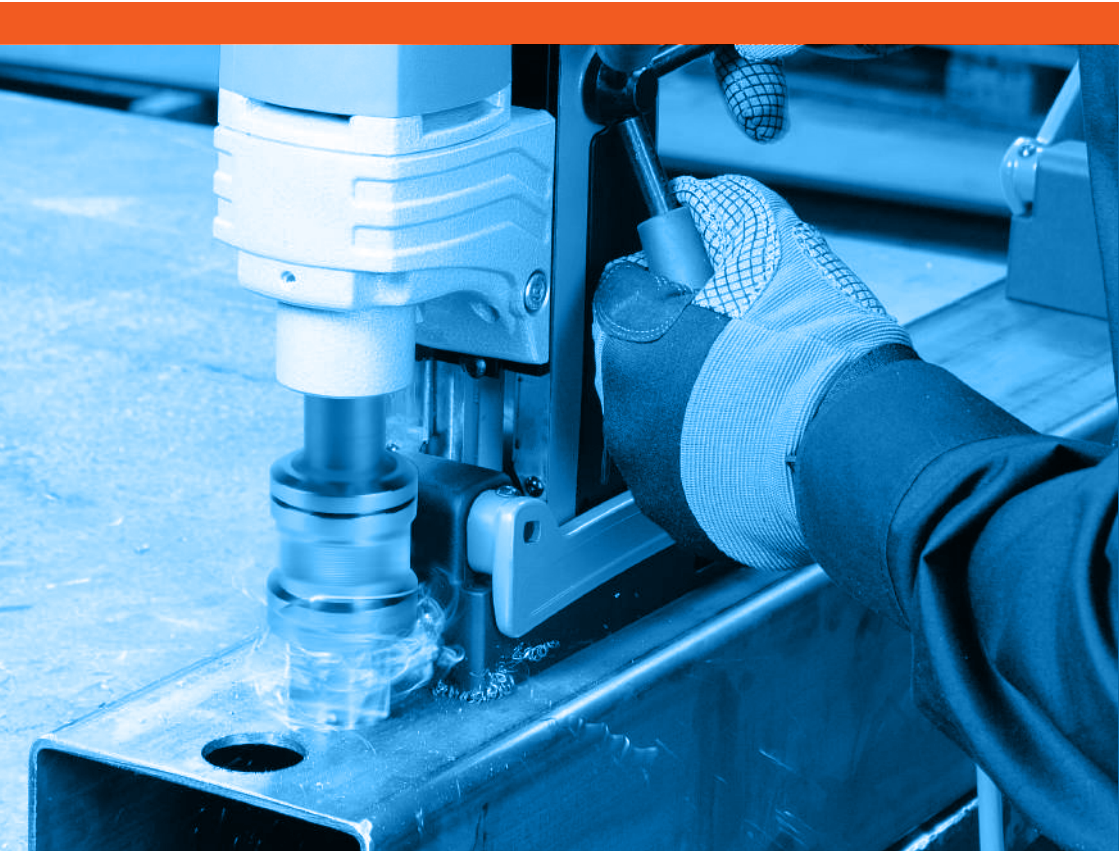





Precision magnetic based drills - made in Germany for the toughest of Australian conditions. Explore the massive range up to 130mm diameter. We have a drill for every job!



**76-78**  
Magnex Drills



**79-87**  
Electric Magnetic Based Drills

# Magnetic Based Drills

## Comparison Table

EM Drills									
Model Name	EM32 Compact	EM35	EM40	EM50	EM50 RLE	EM80	EM80 RLE	EM100 RLE	EM150
Capacity	32mm	35mm	40mm	50mm	50mm	80mm	80mm	100mm	150mm
Forward/Reverse	N	N	N	N	Y	N	Y	Y	N
Speed	450 rpm	450 rpm	450 rpm	250 rpm 450 rpm	50-110 rpm 75-175 rpm 105-245 rpm 165-385 rpm	110 rpm 175 rpm 245 rpm 385 rpm	50-110 rpm 75-175 rpm 105-245 rpm 165-385 rpm	50-150 rpm 75-230 rpm 100-310 rpm 160-490 rpm	30-80 rpm 50-120 rpm 130-350 rpm 210-550 rpm
Magnet	Electric	Electric	Electric	Electric	Electric	Electric	Electric	Electric	Electric

Magnex Drills			
Model Name	Magnex40	Magnex50	Magnex100RLE
Capacity	Ø 12.0 - 40 mm	Ø 12.0 - 50.0 mm	Ø 12.0 - 100.0 mm
Forward/Reverse	N	N	Y
Speed	450 rpm	1. Step 250 rpm 2. Step 450 rpm	1. Step 50 - 110 rpm 2. Step 75 - 175 rpm 3. Step 105 - 245 rpm 4. Step 165 - 385 rpm
Magnet	Permanent	Permanent	Permanent



**The new, unique Magnex Drill provides improved safety by using a powerful magnet that does not need a power supply to work.**

**It adheres to even the thinnest steel sheets or beams allowing:**

- ✦ Safe working environment – magnet adheres without power supply
- ✦ Increased efficiency not having to use secondary clamps, straps, chains or additional counter magnets – less time is spent getting the job done
- ✦ Wider range of application from 1.6mm+ steel – whatever steel you're facing the Magnex will adhere to it

It comes in 3 sizes, the Magnex Drill 40, Magnex Drill 50 (two speed workhorse) and Magnex Drill 100 RLE, so no job is too big or too small. Getting it done faster, safer and more reliably.



# Magnetic Based Drills

## Magnex Drill 40

### Features

- Very light and compact
- Smooth start motor with overload protection and emergency stop
- Stepless adjustment slides
- Self-adjusting guides
- Soft touch grips
- Membrane keyboard

### Capacity



Drill feature and specification	
Core drill dimensions	Ø 12.0 - 40 mm
Cutting depth	50.0 mm
Twist drill	1.0 - 13.0 mm
Counterboring	10.0 - 40.0 mm
Arbors	19 mm Weldon shank
Stroke	105 mm
Height adjustment	80 mm
Gearbox - on-load speed	450 rpm
Power consumption	1,100 W
Voltage	230 V 50/60 Hz
Tool Force (10 mm) / Magnetic adhesion force	2,800 N/17,000 N
Tool force (6 mm S235)	2,300 N
Magnetic base	72 x 190 mm
Weight	9.9 kg



Code	18801	
<b>Magnet</b>		
Permanent Magnet		●
Tin-Coating		●
<b>Scope of delivery</b>		
Metal core drilling machine Magnex40		●
Carrying Case		●
Safety Strap		●
Coolant Device		●
Operating Instructions		●



Code 18107

**Quick-Change Chuck**

# Magnetic Based Drills

## Magnex Drill 50

### Features

- Smooth start motor with overload protection & emergency stop
- 2-Speed workhorse
- Very light and compact
- Stepless adjustment slides
- Self-adjusting guides
- Soft touch grips
- Membrane keyboard

### Capacity

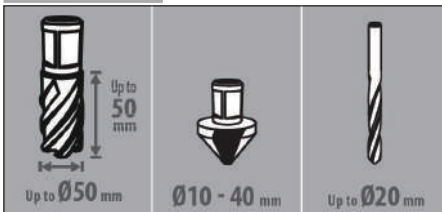

### Drill feature and specification

Core drill dimensions	Ø 12.0 - 50.0 mm
Cutting depth	50.0 mm
Twist drill	1.0 - 20.0 mm
Counterboring	10.0 - 40.0 mm
Arbors	MT2
Stroke	100 mm
Height adjustment	47 mm
Gearbox - on-load speed	1. Step 250 rpm 2. Step 450 rpm
Power consumption	1,200 W
Voltage	230 V 50/60 Hz
Tool force (10 mm S235)	2,800 N
Magnetic base	72 x 190 mm
Weight	11.5 kg



\*Note tool holder pictured is different from standard supply



Code	18850
<b>Magnet</b>	
Permanent Magnet	●
Tin-Coating	●
<b>Scope of delivery</b>	
Metal core drilling machine Magnex50 with AMK2	●
Carrying Case	●
Safety Strap	●
Coolant Device	●
Operating Instructions	●

# Magnetic Based Drills

## Magnex 100 RL-E

### Features

- Smooth start motor with overload protection and emergency stop
- Very light and compact | Stepless adjustment slides
- Self-adjusting guides
- Soft touch grips
- Membrane keyboard

### Capacity

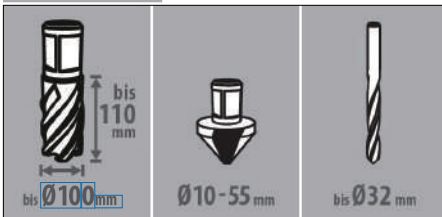

### Drill feature and specification

Core drill dimensions	Ø 12.0 - 100.0 mm
Cutting depth	110.0 mm
Twist drill	Ø 1.0 - 16.0 mm with drill chuck up to Ø 32.0 mm with MT3 DIN 345
Counterboring	Ø 10 - 55.0 mm
Tapping	with tapping chucks: up to M30 with tapping attachment: up to M30
Arbors	MT3
Stroke	190 mm
Height adjustment	60 mm
4-speed gear	right/left 1. Step 50 - 110 rpm 2. Step 75 - 175 rpm 3. Step 105 - 245 rpm 4. Step 165 - 385 rpm
Power consumption	1,800 W
Voltage	230 V 50/60 Hz
Magnetic holding force	22.000 N
Tool force (10 mm)	2.500 N
Magnetic base	94 x 255 mm
Weight	22.6 kg



\*Note tool holder pictured is different from standard supply

Code	18628
<b>Magnet</b>	
Permanent Magnet	●
Tin-Coating	●
<b>Scope of delivery</b>	
Metal core drill Magnex 100 RL-E	●
Incl. coolant system and tool holder with internal cooling	●
Safety Strap	●
Operating Instructions	●





# Magnetic Based Drills

## EM32 Compact

### Features

- Height only 227mm. Can be reduced to 185mm by removing the carry handle
- 2 Coil 16,000N Magnetic Adhesion
- 19mm Weldon Shank – takes standard 30mm depth cutters
- Dual Left or Right Hand Side Handle Mounting
- Integrated Coolant System with Coolant Bottle



### Capacity

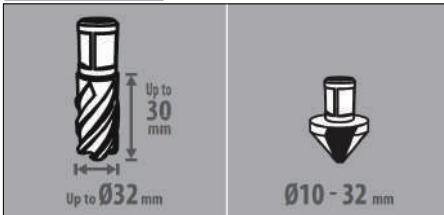

### Drill feature and specification

Core drill dimensions	Ø 12.0 - 32.0 mm
Cutting depth	30.0 mm
Counterboring	Ø 10.0 - 32.0 mm
Tapping	with tapping chucks: up to M30 with tapping attachment: up to M30
Arbors	19 mm Weldon shank
Stroke	45 mm
1-speed gearbox	450 rpm
Power consumption	900 W
Voltage	230 V 50/60 Hz
Magnetic holding force	22.000 N
Tool force (10 mm)/magnetic adhesion strength	2,100 N /16,000 N
Magnetic base	95 x 200 mm
Weight	12.5 kg



Code	18710
<b>Scope of delivery</b>	
Metal core drilling machine EM 32 Compact	●
Carrying case	●
Safety Strap	●
Operating Instructions	●



Use Excision HSS-co cutters see page 90

**Core Drills**

# Magnetic Based Drills



## Features

- Light weight, Simple operation
- Spring loaded guide for rigid gliding and removes vibration
- Direct Weldon arbor type spindle
- Durable switches
- 2 Coil 9,000N Magnetic Adhesion

## Capacity

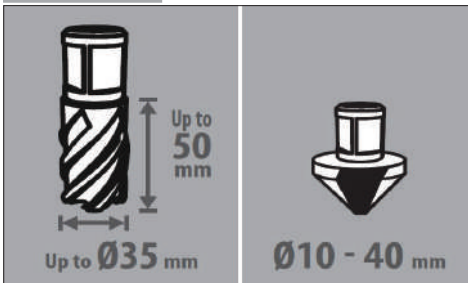

## Drill feature and specification

Core drill dimensions	Ø 12.0 - 35.0 mm
Cutting depth	50.0 mm
Twist drill	1.0 – 13.0 mm
Arbors	19 mm Weldon shank
Stroke	120 mm
Gearbox - on-load speed	450 rpm
Power consumption	1,100 W
Voltage	230 V 50/60 Hz
Tool Force (10 mm) / Magnetic adhesion strength	2,100 N/9,000 N
Magnetic base	70 x 185 mm
Weight	10.6 kg

Code 18400

## Scope of delivery

Metal core drill EMB35	●
Carry case	●
Safety Strap	●
Coolant device	●
Operating instructions	●

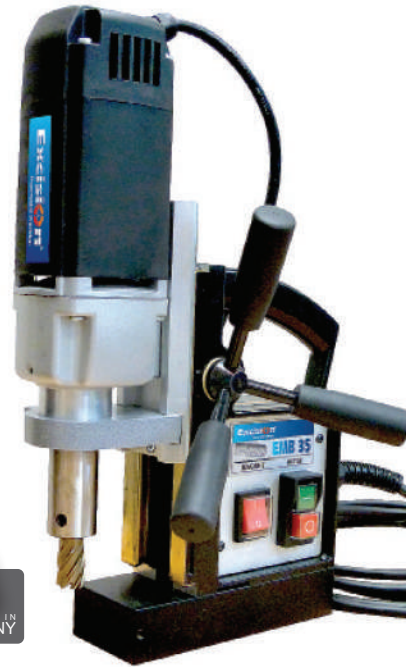





# Magnetic Based Drills

## EM40

### Features

- 9,000N Magnetic Adhesion
- Spring loaded guide for rigid gliding and removes vibration
- Height adjustable slide – enables use of standard twist drills
- Smart Start feature
- Integrated coolant system with coolant unit
- Durable Touch Pad

### Capacity

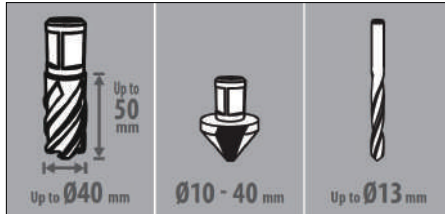

### Drill feature and specification

Core drill dimensions	Ø 12.0 - 40 mm
Cutting depth	50.0 mm
Twist drill	1.0 - 13.0 mm
Counterboring	10.0 - 40.0 mm
Arbors	19mm Weldon shank
Stroke	129 mm
Height adjustment	86 mm
Gearbox - on-load speed	450 rpm
Power consumption	1,100 W
Voltage	230 V 50/60 Hz
Tool Force (10 mm) / Magnetic adhesion strength	2,100 N/9,000 N
Magnetic base	70 x 185 mm
Weight	11.5 kg

Code	18500
------	-------

### Scope of delivery

Metal core drill EM40	●
Carrying case	●
Safety Strap	●
Coolant device	●
Operating Instructions	●



Code 18107

**Quick-Change Chuck**

# Magnetic Based Drills



## Features

- Spring loaded guide for rigid gliding and removes vibration
- Height adjustable slide – enables use of standard twist drills
- 2 Coil 12,000N Magnetic Adhesion
- Integrated coolant system with coolant unit
- Direct Weldon arbor type spindle – ensures concentricity and versatility

## Capacity

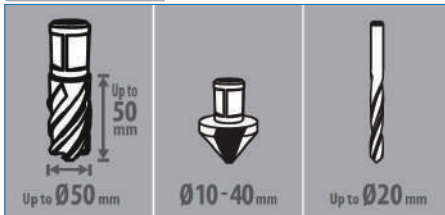

### Drill feature and specification

Core drill dimensions	Ø 12.0 - 50.0 mm
Cutting depth	50.0 mm
Twist drill	1.0 - 16.0 mm with chuck
Counterboring	10.0 - 40.0 mm
Tapping	with tapping attachment M3 - M20
Arbors	19mm Weldon shank
Stroke	190 mm
Height adjustment	100 mm
2-speed gearbox Load speed	1.Step 250 rpm 2.Step 450 rpm
Power consumption	1,200 W
Voltage	230 V 50/60 Hz
Tool Force (10 mm) / Magnetic adhesion strength	3,500 N/12,000N
Magnetic base	92 x 220 mm
Weight	15.0 kg



Code	18510
<b>Scope of delivery</b>	
Metal core drill EM50	●
Carrying case	●
Safety Strap	●
Operating Instructions	●



Code 18106

## Keyed Drill Chuck



# Magnetic Based Drills

## EM50 RL-E

### Features

- Solid Brass Guides
- Oil Bath Gearbox 2 Speed
- Forward-reversible drive
- 3 Coil 16000N Magnetic Adhesion
- Morse Taper 2 spindle
- Variable Speed

### Capacity

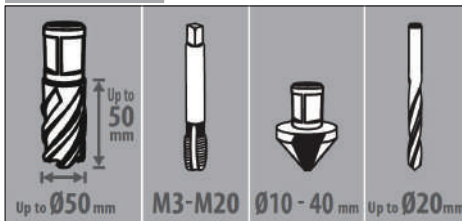

### Drill feature and specification

Core drill dimensions	Ø 12.0 - 50.0 mm
Cutting depth	50.0 mm
Twist drill	with quick-release chuck MT2 up to Ø 20.0 mm with MT 2 DIN 345 direct
Counterboring	10.0 - 40.0 mm
Tapping	with tapping chucks: M3 - M14 with tapping attachment M3 - M20
Arbors	MT2
Stroke	170 mm
Height adjustment	100 mm
2-speed gearbox	right / left 1. Step 100 - 250 rpm 2. Step 180 - 450 rpm
Power consumption	1,200 W
Voltage	230 V 50/60 Hz
Tool Force (10 mm) / Magnetic adhesion strength	3,800 N/16,000 N
Magnetic base	92 x 238 mm
Weight	16.0 kg



\*Note tool holder pictured is supplied separately



Code	18611
<b>Scope of delivery</b>	
Metal core drill EM50 RL-E	●
Carrying case	●
Safety Strap	●
Operating Instructions	●



# Magnetic Based Drills

## EM80

### Features

- 3 Coil Power Increase Magnet
- Durable Touch Pad
- Morse Taper 3
- Height adjustable slide up to 280mm
- Twist Drilling Capacity 32mm

### Capacity

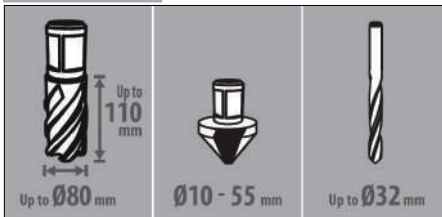

### Drill feature and specification

Core drill dimensions	Ø12.0 - 80.0 mm/ Ø20.0 - 50.0 mm (extra long 110 mm)
Cutting depth	50.0 mm / 110.0 mm
Twist drill	1.0 - 16.0 mm with drill chuck Up to Ø 32.0 mm with MT3 DIN 345
Counterboring	10 - 55.0 mm
Tapping	with tapping attachment: Up to M30
Arbors	MT3
Stroke	190 mm
Height adjustment	100 mm
4-speed gearbox Load speed	1. Step 110 rpm 2. Step 175 rpm 3. Step 245 rpm 4. Step 385 rpm
Power consumption	1,800 W
Voltage	230 V 50/60 Hz
Tool Force (10 mm) / Magnetic adhesion strength	4,000 N/16,000 N
Magnetic base	92 x 220 mm
Weight	19.5 kg



Code	18625
<b>Scope of delivery</b>	
Metal core drill EM80	●
holder with internal cooling (Prod.-No. 18025)	●
Carry case	●
Safety Strap	●
Operating instructions	●





# Magnetic Based Drills

## EM80 RL-E

### Features

- Solid Brass Guides
- Tapping capacity up to M30
- Oil Bath Gearbox 4 Speed
- 3 Coil 20,000N Magnetic Adhesion
- Forward-reversible drive
- Morse Taper 3 spindle
- Variable Speed

### Capacity

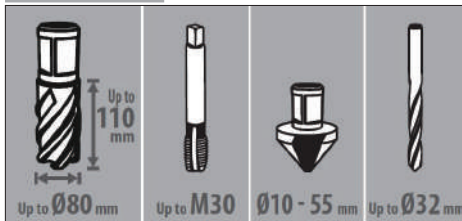

### Drill feature and specification

Core drill dimensions	Ø50.0 mm/110.0 mm
Cutting depth	50.0 mm / 110.0 mm
Twist drill	1.0 - 16.0 mm with drill chuck Up to Ø 32.0 mm with MT3 DIN
Counterboring	10 - 55.0 mm
Tapping	with tapping chucks: Up to M30. With tapping attachment: Up to M30
Arbors	MT3
Stroke	190 mm
Height adjustment	60 mm
2-speed gearbox	1.Step 50 - 110 rpm 2.Step 75 - 175 rpm 3.Step 105 - 245 rpm 4.Step 165 - 385 rpm
Power consumption	1,800 W
Voltage	230 V 50/60 Hz
Tool Force (10 mm) / Magnetic adhesion strength	4,200 N/20,000 N
Magnetic base	92 x 238 mm, 30° adjustable right and left, 10 mm front and back
Weight	22.0 kg



Code	18626
<b>Scope of delivery</b>	
Metal core drill EM80 RL-E	●
Carrying case	●
Coolant device	●
Safety Strap	●
Operating instructions	●





**Best Match**



Code 18651

Quick Release Arbor

# Magnetic Based Drills

## EM100 RL-E

### Features

- 3 Coil 20,000N Magnetic Adhesion
- Solid Brass Guides
- Durable Touch Pad
- Morse Taper 3
- Height adjustable slide up to 280mm
- Twist Drilling Capacity 32mm

### Capacity

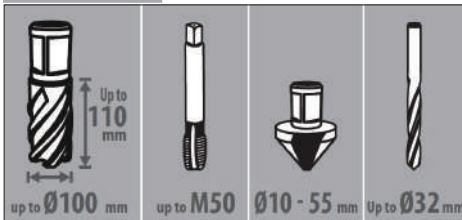

### Drill feature and Specification

Core drill dimensions	Ø12.0 - 100.0 mm
Cutting depth	110.0 mm
Twist drill	Ø 1.0 - 16.0 mm with drill chuck Up to Ø 32.0 mm with MT3 DIN 345
Counterboring	10.0 - 55.0 mm
Tapping	with tapping chucks: Up to M30 with tapping attachment: Up to M30
Arbors	MT3
Stroke	245 mm
Height adjustment	116 mm
4-speed gearbox	1. Step 50 - 150 rpm 2. Step 75 - 230 rpm 3. Step 100 - 310 rpm 4. Step 160 - 490 rpm
Power consumption	2,500 W (230 V)
Voltage	230 V 50/60 Hz
Tool Force (10 mm) / Magnetic adhesion strength	4,000 N/20,000 N
Magnetic base	92 x 238 mm, 30° adjustable right and left, 10 mm front and back
Weight	28.0 kg



Code 18634

### Scope of delivery

Metal core drill EM100 RL-E	●
Carrying case	●
Coolant device	●
Safety Strap	●
Operating instructions	●



SCAN TO  
GO TO LINK



Code 18025

**Tool Holder AMK3**

# Magnetic Based Drills

## EM150

### Features

- 6 Coil MPI 32,000N Magnet
- Tapping capacity up to M42
- Twist drill capacity up to 45mm
- Durable Touch Pad
- Solid brass guides



### Capacity



### Drill feature and specification

Core drill dimensions	Ø12.0 - 150.0 mm / Ø20.0 - 50.0 mm (extra long 110 mm)
Cutting depth	50.0 mm / 110.0 mm
Twist drill	Up to Ø 45.0 mm with MT4 DIN 345 direct
Counterboring	10.0 - 80.0 mm
Tapping	with tapping attachment Up to M42
Arbors	MT4
Stroke	230 mm
Height adjustment	100 mm
Power consumption	2,500 W
Voltage	230 V 50/60 Hz
Tool Force (10 mm) / Magnetic adhesion strength	5,000 N/33,000 N
Magnetic base	90 x 400 mm
Weight	34.5 kg
4-speed gearbox	1.Step 30 - 80 rpm 2.Step 50 - 120 rpm 3.Step 130 - 350 rpm 4.Step 210 - 550 rpm



Code	18645
------	-------

### Scope of delivery

Metal core drill EM150	●
Transportation packing	●
Coolant device	●
Safety Strap	●
Operating instructions	●

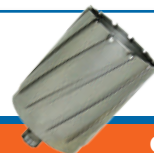

Use Excision TCT cutters see page 96

### Core Drills

# Magnetic Based Drills



Description	Code	Magnex 40 EMB 35 EM 40 EM 50	Magnex 50 EM 50 RL-E	EM 80 EM 80 RL-E EM 100 RL-E	Part Image
Quick-release tool holder • Morse taper 2 • with automatic internal cooling • suitable for all machines with drill spindle MT 2 • Application range to 40 mm core drill Ø	18650		●		
Quick-release tool holder • Morse taper 3 • with automatic internal cooling • suitable for all machines with drill spindle MT 3 • Application range to 40 mm core drill Ø	18651			●	
Keyed Drill Chuck with Weldon arbor for twist drills • Ø 1 - 13 mm	18106	●			
Quick-release chuck with Weldon arbor for twist drills • Ø 1 - 13 mm	18107	●			
Keyed Drill Chuck with Morse taper 3 for twist drills • Ø 1 - 16 mm	18011			●	
Quick-release chuck with Morse taper 2 for twist drills • Ø 1 - 16 mm	18008		●		
Quick-release chuck with Morse taper 3 for twist drills • Ø 1 - 16 mm	18009			●	
Tool holder AMT-2 without internal cooling	21003		●		
Tool holder AMT-3 without internal cooling	21025			●	
Adapter sleeve MT 3/2	18023			●	
Tool holder AMK-2 Morse taper 3 for core drills • Ø 12 - 100 mm • with automatic internal cooling • suitable for all machines with drill spindle MT 2	18003		●		
Tool holder AMK-3 Morse taper 3 for core drills • Ø 12 - 100 mm • with automatic internal cooling • suitable for all machines with drill spindle MT 3	18025			●	



# Magnetic Based Drills



## Adapters

Description	Code	Part Image
<b>Chuck Adaptor</b> <ul style="list-style-type: none"> <li>Suits standard UNF 1/2 chucks</li> <li>Universal weldon shank</li> </ul>	21105	
<b>EXTENSION ADAPTER</b> With Weldon shank and ejector pin. For use on core drills 25 - 30 - 35 - 50 mm cutting depth in cases when the surface of the material to be drilled is deeper than the stand space of the machine. The first ejector pin triggers the second ejector pin; the coolant flows through the borehole to the core drill. Total adapter length: 80 mm	20206	

## Tapping Chuck

Description	Code	Shaft	EM 50	EM 80	Part Image
<b>TAPPING ATTACHMENT M3-M12</b> <b>Scope of delivery:</b> with Weldon Shank and MT2, interchangeable, Plastic case, manual	18652	MT2 + Weldon Shank	●	● with adapter sleeve MT 3/2	
<b>TAPPING ATTACHMENT M10-M20</b> <b>Scope of delivery:</b> with Weldon Shank and MT2, interchangeable, Plastic case, manual	18653	MT2 + Weldon Shank	●	● with adapter sleeve MT 3/2	

## Other Accessories

Description	Features	Code	Part Image
VACUBEST VACUUM	<ul style="list-style-type: none"> <li>For non-magnetic surfaces</li> <li>400 x 200mm vacuum plate</li> <li>Complete with vacuum pump</li> </ul>	18150	NB: Drill not included
COOLANT UNIT	<ul style="list-style-type: none"> <li>Includes tank, tap &amp; hose</li> </ul>	18104	
TRANSPORT CASE	<ul style="list-style-type: none"> <li>To suit EM40 and EM50</li> </ul>	18532	
TRANSPORT CASE	<ul style="list-style-type: none"> <li>To suit EM80, RLE 50, RLE 80</li> </ul>	18566	
PIPE CLAMPING ATTACHMENT	<ul style="list-style-type: none"> <li>For pipes ø80-300mm</li> <li>Single chain</li> </ul>	18109	



# Core Drills





Excision has a large range of core drills for drilling all diameters and depths. The Excision core drill is unique in geometry and drills easier for longer.



**92-95**

Cobalt Core Drills



**96-100**

TCT Core Drills

E  
T

info@excision.com.au  
+61 3 5551 4555

# Core Drills

## Excision Core Drills

- HSS - 5% Cobalt for increased life
- Multi-fit shank
- One pin suits all sizes
- Thinner wall for faster drilling and less power to drive



### The Excision Core Drill

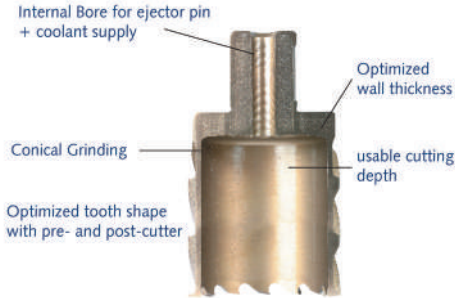

Economies on chipping volume of a core drill compared with a twist drill





# Core Drills



## Core Drills

5% Cobalt 30mm depth

- 1 pin fits every diameter - 12mm to 50mm
- High Speed Steel with 5% Cobalt Cutters  
- Longer Lasting - Will drill harder materials
- Multi Fit - Fits all makes of magnetic based drill including all quick change systems



Diameter	Code	Diameter	Code
12	1905012030	32	1905032030
13	1905013030	33	1905033030
14	1905014030	34	1905034030
15	1905015030	35	1905035030
16	1905016030	36	1905036030
17	1905017030	37	1905037030
18	1905018030	38	1905038030
19	1905019030	39	1905039030
20	1905020030	40	1905040030
21	1905021030	41	1905041030
22	1905022030	42	1905042030
23	1905023030	43	1905043030
24	1905024030	44	1905044030
25	1905025030	45	1905045030
26	1905026030	46	1905046030
27	1905027030	47	1905047030
28	1905028030	48	1905048030
29	1905029030	49	1905049030
30	1905030030	50	1905050030
31	1905031030		



Use XDP 905 paste or spray for longer life



Suitable Pin RA359-B

1926500

### Stack Cutters:

HSS-Co cutters suitable for drilling multiple layers are available on request for an additional cost.

# Core Drills

## HSS-Co Core Drills 5% Cobalt 50mm depth

- 1 pin fits every diameter - 12mm to 60mm
- High Speed Steel with 5% Cobalt Cutters  
- Longer Lasting - Will drill harder materials
- Multi Fit - Fits all types of magnetic based drill including all quick change systems

Diameter	Code	Diameter	Code
12	1905012050	37	1905037050
13	1905013050	38	1905038050
14	1905014050	39	1905039050
15	1905015050	40	1905040050
16	1905016050	41	1905041050
17	1905017050	42	1905042050
18	1905018050	43	1905043050
19	1905019050	44	1905044050
20	1905020050	45	1905045050
21	1905021050	46	1905046050
22	1905022050	47	1905047050
23	1905023050	48	1905048050
24	1905024050	49	1905049050
25	1905025050	50	1905050050
26	1905026050	51	1905051050
27	1905027050	52	1905052050
28	1905028050	53	1905053050
29	1905029050	54	1905054050
30	1905030050	55	1905055050
31	1905031050	56	1905056050
32	1905032050	57	1905057050
33	1905033050	58	1905058050
34	1905034050	59	1905059050
35	1905035050	60	1905060050
36	1905036050		



Suitable Pin RA360  
190500



# Core Drills

## Core Drills Set

- 4 cutters & 1 pin to suit
- 1 x 14, 1 x 18, 1 x 20, 1 x 22 and 1 pin
- Presented in heavy duty plastic case.
- HSS - 5% Cobalt



Piece Set	5 Piece	5 Piece
Cutter Depth	30mm	50mm
CODE	1905005030	1905005050

# Core Drills

## Excision TCT Core Drills

The Dependable Precision TCT core drills - tested and proven to make holes in the toughest steels. Tungsten carbide tipped core drills ( annular cutters / broach cutters) are designed for long life when drilling hardened steel materials.

The toughened edge of the Tungsten tips gives excellent cutting life and consistent performance when compared to regular HSS Core Drills.

Designed for use with Magnetic Based Drills in situations where regular mag drill bits burn out or blunten very rapidly. They will reduce your costs and increase your speed and performance.

### **Recommended for use with the following materials:**

- Hardened & case hardened Steel
- Mild steels & regular metals
- Bialloy
- Stainless Steel
- Steel Castings





# Core Drills

## TCT Core Drills 35mm depth

Diameter	Code
12	2005012035
13	2005013035
14	2005014035
15	2005015035
16	2005016035
17	2005017035
18	2005018035
19	2005019035
20	2005020035
21	2005021035

Diameter	Code
22	2005022035
23	2005023035
24	2005024035
25	2005025035
26	2005026035
27	2005027035
28	2005028035
29	2005029035
30	2005030035
31	2005031035

Diameter	Code
32	2005032035
33	2005033035
34	2005034035
35	2005035035
36	2005036035
37	2005037035
38	2005038035
39	2005039035
40	2005040035



## TCT Core Drills 50mm depth

Diameter	Code
12	2005012050
13	2005013050
14	2005014050
15	2005015050
16	2005016050
17	2005017050
18	2005018050
19	2005019050
20	2005020050
21	2005021050
22	2005022050
23	2005023050
24	2005024050
25	2005025050
26	2005026050
27	2005027050
28	2005028050
29	2005029050
30	2005030050
31	2005031050
32	2005032050

Diameter	Code
33	2005033050
34	2005034050
35	2005035050
36	2005036050
37	2005037050
38	2005038050
39	2005039050
40	2005040050
41	2005041050
42	2005042050
43	2005043050
44	2005044050
45	2005045050
46	2005046050
47	2005047050
48	2005048050
49	2005049050
50	2005050050
51	2005051050
52	2005052050
53	2005053050

Diameter	Code
54	2005054050
55	2005055050
56	2005056050
57	2005057050
58	2005058050
59	2005059050
60	2005060050
61	2005061050
62	2005062050
63	2005063050
64	2005064050
65	2005065050
66	2005066050
67	2005067050
68	2005068050
69	2005069050
70	2005070050
71	2005071050
72	2005072050
73	2005073050
74	2005074050



Diameter	Code
75	2005075050
76	2005076050
77	2005077050
78	2005078050
79	2005079050
80	2005080050

# Core Drills

## TCT Core Drills 75mm depth

- Depth of cut 75mm
- Tungsten Carbide Tips for harder metals and faster drilling
- Universal Shank (19mm) for all magnetic drills

Diameter	Code
14	2005014075
15	2005015075
16	2005016075
17	2005017075
18	2005018075
19	2005019075
20	2005020075
21	2005021075
22	2005022075
23	2005023075
24	2005024075
25	2005025075
26	2005026075
27	2005027075
28	2005028075
29	2005029075
30	2005030075
31	2005031075
32	2005032075
33	2005033075
34	2005034075
35	2005035075
36	2005036075

Diameter	Code
37	2005037075
38	2005038075
39	2005039075
40	2005040075
41	2005041075
42	2005042075
43	2005043075
44	2005044075
45	2005045075
46	2005046075
47	2005047075
48	2005048075
49	2005049075
50	2005050075
51	2005051075
52	2005052075
53	2005053075
54	2005054075
55	2005055075
56	2005056075
57	2005057075
58	2005058075
59	2005059075

Diameter	Code
60	2005060075
61	2005061075
62	2005062075
63	2005063075
64	2005064075
65	2005065075
66	2005066075
67	2005067075
68	2005068075
69	2005069075
70	2005070075
71	2005071075
72	2005072075
73	2005073075
74	2005074075
7	2005075075
76	2005076075
77	2005077075
78	2005078075
79	2005079075
80	2005080075





**Best Match**

Use XDP 905 foam for longer life

**XDP905 Foam**



# Core Drills

## TCT Core Drills 100mm depth

- Depth of cut 100mm
- Tungsten Carbide Tips for harder metals and faster drilling
- Universal Shank (19mm) for all magnetic drills

Diameter	Code
18	2005018100
19	2005019100
20	2005020100
21	2005021100
22	2005022100
23	2005023100
24	2005024100
25	2005025100
26	2005026100
27	2005027100
28	2005028100
29	2005029100
30	2005030100
31	2005031100
32	2005032100
33	2005033100
34	2005034100
35	2005035100
36	2005036100
37	2005037100
38	2005038100
39	2005039100
40	2005040100

Diameter	Code
41	20050410100
42	20050420100
43	20050430100
44	20050440100
45	20050450100
46	20050460100
47	20050470100
48	20050480100
49	20050490100
50	20050500100
51	20050510100
52	20050520100
53	20050530100
54	20050540100
55	20050550100
56	20050560100
57	20050570100
58	20050580100
59	20050590100
61	20050610100
62	20050620100
63	20050630100
64	20050620100

Diameter	Code
65	2005065100
66	2005066100
67	2005067100
68	2005068100
69	2005069100
70	2005070100
71	2005071100
72	2005072100
73	2005073100
74	2005074100
75	2005075100
76	2005076100
77	2005077100
78	2005078100
79	2005079100
80	2005080100
85	2005085100
90	2005090100
95	2005095100
100	2005100100

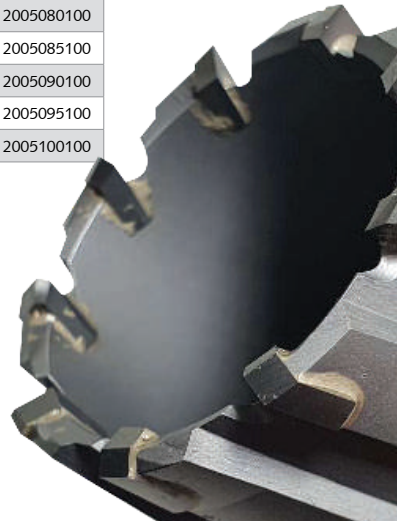

# Core Drills

## TCT Core Drills 150mm depth

- Depth of cut 150mm
- Tungsten Carbide Tips for harder metals and faster drilling
- Universal Shank (19mm) for all magnetic drills

Diameter	Code
22	2005022150
24	2005024150
25	2005025150
26	2005026150
28	2005028150
30	2005030150
32	2005032150
34	2005034150
35	2005035150
36	2005036150
38	2005038150
40	2005040150
42	2005042150
44	2005044150
45	2005045150
46	2005046150
48	2005048150
50	2005050150
52	2005052150
54	2005054150
55	2005055150
56	2005056150

Diameter	Code
58	2005058150
60	2005060150
61	2005061150
62	2005062150
63	2005063150
64	2005064150
65	2005065150
66	2005066150
67	2005067150
68	2005068150
69	2005069150
70	2005070150
71	2005071150
72	2005072150
73	2005073150
74	2005074150
75	2005075150
76	2005076150
77	2005077150
78	2005078150
79	2005079150
80	2005080150



EM 50 Magnetic Drill  
- Has a huge stroke  
of 190mm capable  
for these long cutters



**EM50**

# Core Drills



## Ejector Pins

Pins to suit HSS-Co Core Drills

Depth of Cutter	Diameter of Cutter	Description	Code
30mm	All Diameters	PIN Ø6.35 x 77mm	1926500
50mm	All Diameters	PIN Ø6.35 x 102mm	1950500

## Pins to suit TCT Core Drills

Depth of Cutter	Diameter of Cutter	Description	Code
35mm	12mm	PIN Ø6.35 x 91mm	20056091
50mm	12mm	PIN Ø6.35 x 112mm	20056112
35mm	13-16mm	PIN Ø7.09 x 91mm	20057091
50mm	13-16mm	PIN Ø7.09 x 112mm	20057112
75mm	14-16mm	PIN Ø7.09 x 140mm	20057140
35mm	17+	PIN Ø8 x 91mm	20058091
50mm	17+	PIN Ø8 x 112mm	20058112
75mm	17+	PIN Ø8 x 140mm	20058140
100mm	17+	PIN Ø8 x 160mm	20058160
150mm	17+	PIN Ø8 x 220mm	20058220



## HSS Cobalt Countersink

- Multi fit - suits all makes of magnetic based drills
- HSS with 5% Cobalt

Diameter	Code
25mm	18533
40mm	18534
65mm	18536



## HSS - 5% Cobalt RQX

25mm & 50mm depth

**CUTTER DIA 14-38MM**

- Heavy duty with keyway & feather key Alfa
- Alfa "Chip-Breaker System"
- Suits Weldon shank drilling machines
- HSS 5% cobalt with TiAlN coating





# Holesaws



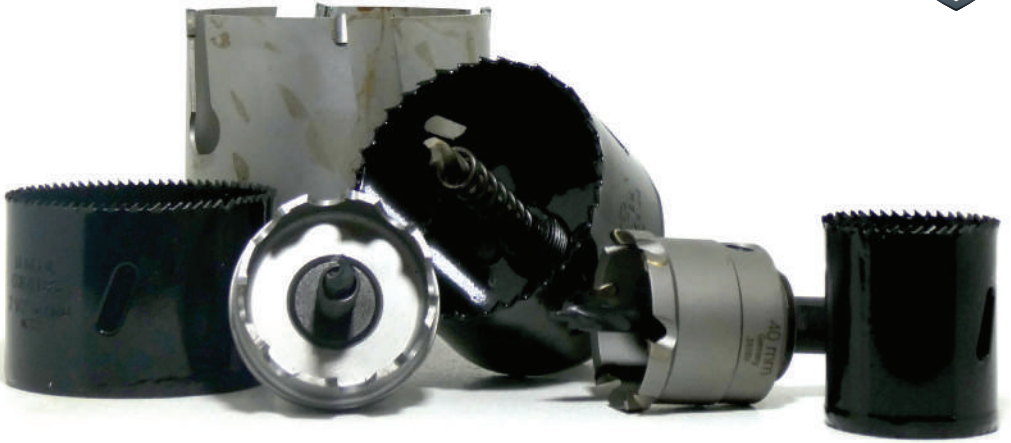

Excision Holesaws are sourced from quality steel. Working with world leading manufacturers to bring you the best. Contact us about our detailed range to address your specific requirements.



**104-107**

Bimetal Holesaws



**108-110**

TCT Holesaws



**111**

Step Drills

# Holesaws

## 4/6 TPI HSS-Bimetal Holesaws Coarse Tooth Cobalt M42

- M42 material for increased cutting life
- 8% cobalt
- Quick, precise and effortless cutting of holes in steel, stainless steel, copper, wood (including nails), plywood, veneers, melamines, plastics, pipes, tubing and more
- Re-sharpenable
- For use with hand and pedestal drilling machines
- Solid base allows a stronger thread giving greater strength and stability whilst reducing the risk of stripped threads



Diameter	Code
14	0500014
16	0500016
17	0500017
19	0500019
20	0500020
21	0500021
22	0500022
24	0500024
25	0500025
27	0500027
29	0500029
30	0500030
32	0500032
33	0500033
35	0500035
37	0500037
38	0500038
40	0500040
41	0500041

Diameter	Code
43	0500043
44	0500044
46	0500046
48	0500048
51	0500051
52	0500052
54	0500054
57	0500057
59	0500059
60	0500060
64	0500064
65	0500065
67	0500067
68	0500068
70	0500070
73	0500073
76	0500076
79	0500079
83	0500083

Diameter	Code
86	0500086
89	0500089
92	0500092
95	0500095
98	0500098
102	0500102
105	0500105
108	0500108
111	0500111
114	0500114
121	0500121
123	0500123
127	0500127
140	0500140
152	0500152
160	0500160
168	0500168
177	0500177
210	0500210





# Holesaws

## 10 TPI HSS-Bimetal Holesaws Fine Tooth Cobalt M42





Perfect for Thin Wall Drilling  
Applications in Mild & Stainless Steel

- M42 material for increased cutting life
- Fine tooth to prevent stripping - perfect for sheetmetal and tubes including stainless steel
- 8% Cobalt
- Quick, precise and effortless cutting of holes in steel, stainless steel, copper, wood (including nails), plywood, veneers, melamines, plastics, pipes, tubing and more
- Re-sharpenable
- For use with hand and pedestal drilling machines
- Solid base allows a stronger thread giving greater strength and stability whilst reducing the risk of stripped threads and inserts





Diameter	Code	Diameter	Code	Diameter	Code
14	0510014	38	0510038	68	0510068
16	0510016	40	0510040	70	0510070
17	0510017	41	0510041	76	0510076
19	0510019	43	0510043	79	0510079
20	0510020	44	0510044	83	0510083
21	0510021	46	0510046	86	0510086
22	0510022	48	0510048	89	0510089
24	0510024	51	0510051	92	0510092
25	0510025	54	0510054	95	0510095
27	0510027	57	0510057	98	0510098
29	0510029	59	0510059	102	0510102
30	0510030	60	0510060	108	0510108
32	0510032	64	0510064	111	0510111
33	0510033	65	0510065	114	0510114
35	0510035	67	0510067		

# Holesaws

## HSS-Bimetal M42 Holesaw Accessories

Description	Features	Code	Part image	
A6 FOR Ø 14-30	●To suit 10mm (3/8") chucks	0501001		
A2-SS FOR Ø 32-152	●To suit 10mm (3/8") chucks	0501003		
A3-SS FOR Ø 32-210	●To suit 13mm (1/2") chucks	0501006		
A5-SS FOR Ø 32-210	●To suit 16mm (5/8") chucks	0501008		
A6-SDS FOR Ø 14-30	●To suit SDS Multifit chucks	0501002		
A2-SDS FOR Ø 32-152	●To suit SDS Multifit chucks	0501005		
SPARE DRILL Ø 6.35 X 80MM	●Suits all standard arbors ●80mm length	0502001		
SPARE DRILL Ø 6.35 X 95MM	●Suits all standard arbors ●95mm length	0502002		
EJECTOR SPRING	●Suits all standard arbors	0502004		
ARBOR EXTENSION 300MM	●Suits A6, A2, A3 arbors ●Double ended	0501010		 
SCREW	●To suit A6 Arbor	0501025		
MANDREL BUSH	●To suit A6 Arbor ●Suits 32mm h/saw and over	0501020		
SCREW	●To suit A2 SS Arbor	0501026		

## HSS-Bimetal M42 Holesaw Sets

Description	Features	Code	Part image
GENERAL PURPOSE KIT 4/6TPI VARI-PITCH	<ul style="list-style-type: none"> <li>● 12 Pieces</li> <li>● 1 x 16, 1 x 19, 1 x 22, 1 x 29, 1 x 35, 1 x 44, 1 x 51, 1 x 57, 1 x 67mm</li> <li>● 1 x Arbor A6, 1 x Arbor A2-SS, 1 x Spare Drill</li> <li>● Presented in a heavy duty plastic case</li> </ul>	0503006	
INDUSTRIAL KIT 4/6TPI VARI-PITCH	<ul style="list-style-type: none"> <li>● 15 Pieces</li> <li>● 1 x 16, 1 x 19, 1 x 22, 1 x 25, 1 x 29, 1 x 32, 1 x 35, 1 x 38, 1 x 44, 1 x 51, 1 x 64, 1 x 76mm</li> <li>● 1 x Arbor A6, 1 x Arbor A2-SS, 1 x Spare Drill</li> <li>● Presented in a heavy duty plastic case</li> </ul>	0503007	
GENERAL PURPOSE KIT 10TPI FINE TOOTH	<ul style="list-style-type: none"> <li>● 12 Pieces</li> <li>● 1 x 16, 1 x 19, 1 x 22, 1 x 29, 1 x 35, 1 x 44, 1 x 51, 1 x 57, 1 x 67mm</li> <li>● 1 x Arbor A6, 1 x Arbor A2-SS, 1 x Spare Drill</li> <li>● Presented in a heavy duty plastic case</li> </ul>	0513006	
INDUSTRIAL KIT 10TPI FINE TOOTH	<ul style="list-style-type: none"> <li>● 15 Pieces</li> <li>● 1 x 16, 1 x 19, 1 x 22, 1 x 25, 1 x 29, 1 x 32, 1 x 35, 1 x 38, 1 x 44, 1 x 51, 1 x 64, 1 x 76mm</li> <li>● 1 x Arbor A6, 1 x Arbor A2-SS, 1 x Spare Drill</li> <li>● Presented in a heavy duty plastic case</li> </ul>	0513007	

# Holesaws

## TCT Holesaws Short Series

Premium Holesaws for sheetmetal up to 4mm  
Suitable for pipes, vaulted or profile surfaces  
- even weld seams, stainless steel up to 2mm,  
mild steel up to 4mm, nonferrous, plastics,  
wood up to 12mm. TCT holesaws can be re-  
sharpened. It is possible, depending on the  
condition, to replace broken teeth.

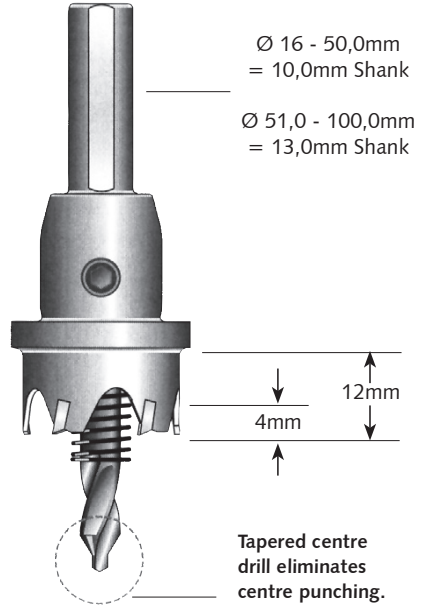

Diameter	Code	Diameter	Code
16	0600160	42	0600420
18	0600180	44	0600440
19	0600190	45	0600450
20	0600200	48	0600480
21	0600210	50	0600500
22	0600220	51	0600510
24	0600240	54	0600540
25	0600250	60	0600600
26	0600260	64	0600640
28	0600280	70	0600700
30	0600300	76	0600760
32	0600320	80	0600800
34	0600340	85	0600850
35	0600350	90	0600900
38	0600380	100	0601000
40	0600400	110	0601100

Description	Features	Code	
TCT SHORT SERIES SET	<ul style="list-style-type: none"> <li>5 TCT Holesaws</li> <li>1 x 16, 1 x 20, 1 x 25, 1 x 32, 1 x 40mm</li> <li>Presented in a heavy duty plastic case</li> </ul>	0600001	
SPARE DRILL	<ul style="list-style-type: none"> <li>Ø 6 x 50mm</li> <li>Tapered centre tip</li> </ul>	0602650	
EJECTOR SPRING	<ul style="list-style-type: none"> <li>Suits 6mm drill</li> </ul>	0602006	

## TCT Holesaws Long Series

Especially developed for the use on pipes, vaulted materials, for unalloyed and alloyed steels, nonferrous metals, plastics as well as glass fibre reinforced plastic.

- For material thickness up to 4 mm, 2 mm stainless steel.
- When using hand drilling machines, recommended up to max. Ø 40 mm

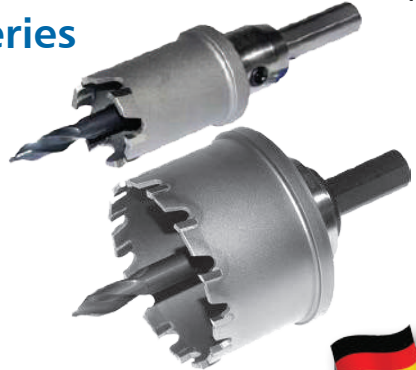

Diameter	Code	Diameter	Code
16	0700160	42	0700420
18	0700180	44	0700440
19	0700190	45	0700450
20	0700200	48	0700480
21	0700210	50	0700500
22	0700220	51	0700510
24	0700240	54	0700540
25	0700250	60	0700600
26	0700260	64	0700640
28	0700280	70	0700700
30	0700300	76	0700760
32	0700320	80	0700800
34	0700340	85	0700850
35	0700350	90	0700900
38	0700380	100	0701000
40	0700400	110	0701100

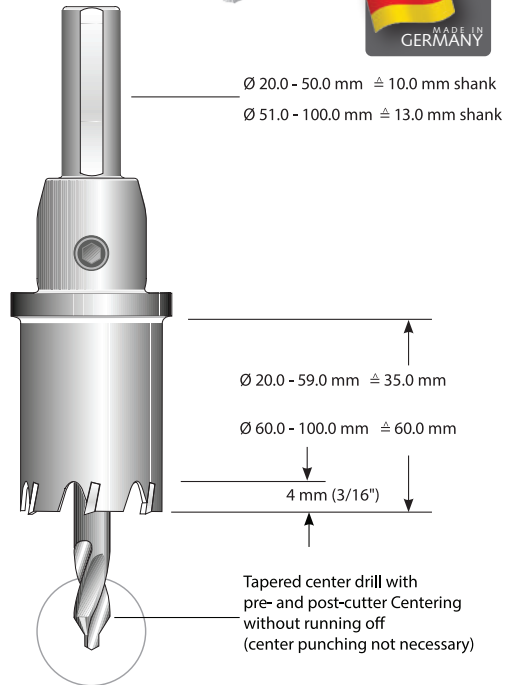

Description	Features	Code	
SPARE DRILL	Ø 6 x 80mm Tapered centre tip	0702680	
EJECTOR SPRING	• Suits 6mm drill	0702006	

# Holesaws

## TCT Holesaw FRP Type

### Premium Multi Purpose Holesaws

- Cutting depth 60mm
- Fast, accurate & efficient TCT holesaws suitable for a wide range of applications including:
  - Wood
  - Plywood
  - Clay Tiles
  - Paper Based
  - Fibre Glass Reinforced Plastic Laminate
  - Hollowgauge Brick/Stone
  - Laminated Board
  - Plasterboard
  - Aluminium
  - PVC
- No blocking due to optimal geometry
- In the event of a tooth breaking, the teeth can be resharpened or replaced, depending on the condition.



Diameter	Code
25	0740025060
30	0740030060
35	0740035060
40	0740040060
45	0740045060
50	0740050060
55	0740055060
58	0740058060
60	0740060060
63	0740063060

Diameter	Code
65	0740065060
68	0740068060
70	0740070060
74	0740074060
76	0740076060
80	0740080060
85	0740085060
90	0740090060
95	0740095060
105	0740105060

Description	Size	Code	
SPARE DRILL	● Ø 7.2 X 100MM	0742000003	
RIM COUNTERSINK	Ø 68MM	0741068000	
SW12 ARBOR		0742000001	
SDS ARBOR		0742000002	

# Holesaws

## Step Drills

- Dual-step replaceable tip
- HSS Co (8% Cobalt) - exceptionally hardwearing, longer lasting
- Titanium aluminium nitride (TiAlN) coated - an extremely high performance coating recommended for high tensile materials including stainless steel
- 3 Spiral Flutes - smoother, faster drilling guarantees a clean finish to the hole
- Can be resharpened



Description	Size	Code
STEP DRILL	5-20MM	26020
STEP DRILL	5-30MM	26030
STEP DRILL	5-40MM	26040
STEP DRILL	5-50MM	26050
SPARE TIPS	1 PIECE	26002

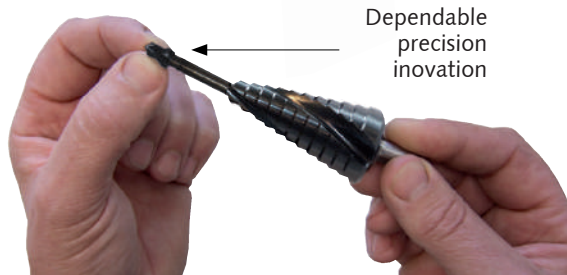
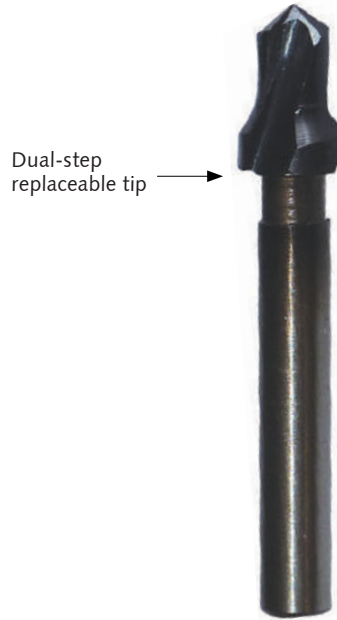



# Punch & Die Tooling

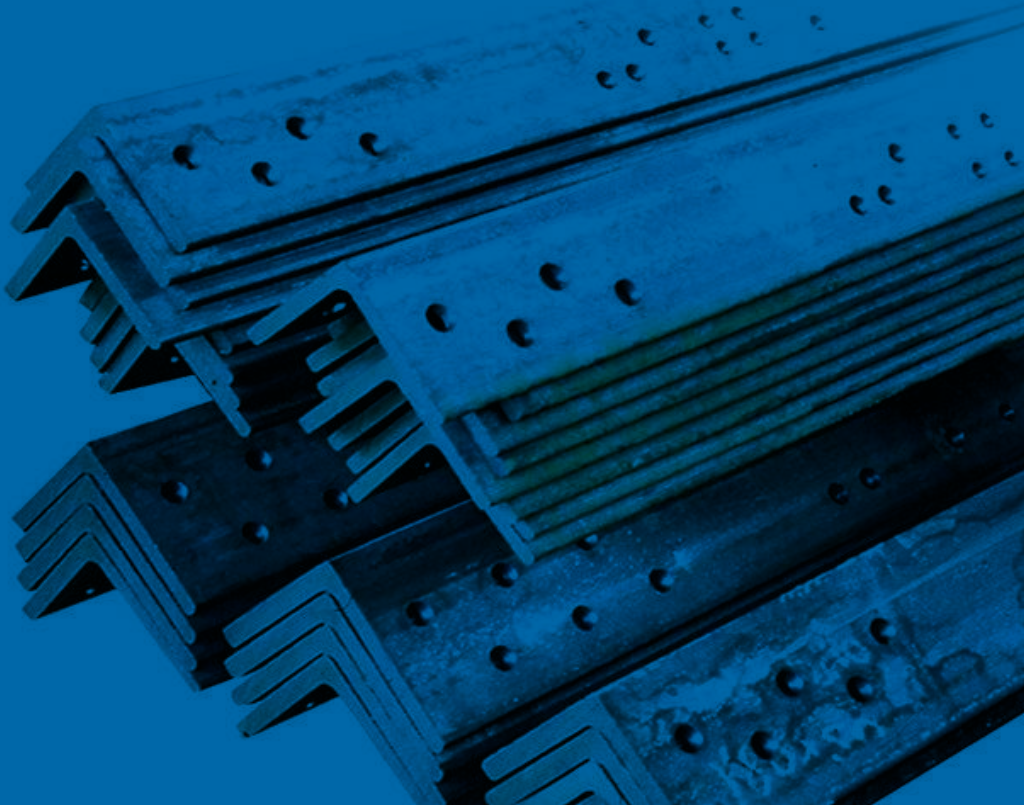





Excision sources and has huge stocks of the highest quality Punch & Die tooling. Punches & Dies are available for all models of cropping machines and can be manufactured for any size and shape of hole.

### Complete Range of Punch & Die Tooling to Suit:

Alfra	Ficpe	Marksman	Pullmax	Suresharp
Coburn	Gairu	Machine Maker	Punchtech	Thomas
Comaco	Geka	Metalmaster	QPS	TSP (hot work)
Diacro	Henry Pels	Metalmaster	Rocky	Uni-hydro
Durma	IMS	Nitto Kohki	Sahinler	Valdarno
Dvorak	Isumi	Nova Press	Samurai	Valdarno
Edwards	J.R. 65	Omes	Scotchman	Weidemann
Enerpac	Jing Jang	Omera	Scotchman	
Fabryka	Kippen	Peddinghaus	Sharp	
Fabtech	Kingsland	Pacific	Stanko	
Femco	Madison	Piranha	Sunrise	

# Punch & Die Tooling

## Punch Selection Chart

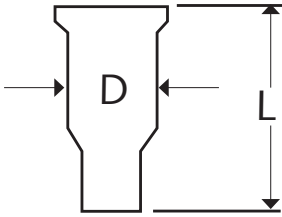

Size range			Machine Brand											
Round	Oblong (max)	Square	Sunrise	Mubea	Geka	Kingsland	Ficep	Peddighaus	Alfra/Nitib/Promotech	Metalmaster	Marksman	Scotchman	Omera	Ehoma

Style	Code	D	L	Round	Oblong (max)	Square	Sunrise	Mubea	Geka	Kingsland	Ficep	Peddighaus	Alfra/Nitib/Promotech	Metalmaster	Marksman	Scotchman	Omera	Ehoma
Group 1	24101	15	40	3-15mm	10x15mm	3-10mm	Y*	Y						Y				
Group 2	24102	30	70	3-30mm	24x30mm	3-21mm	Y*	Y						Y	Y			
Group 3	24103	40	70	31-40mm	26x40mm	22-27mm	Y	Y						Y				
Group 4	24104	50	70	40-50mm	28x50mm	28-35mm	Y	Y						Y				
210/13	24105	27	49	3-27mm	20x27mm	1-19mm					Y	Y						
210/16	24106	31	64	3-31mm	24x30mm	3-21mm	Y		Y	Y		Y				Y		
9004	24107	38	61	3-38mm	26x38mm	3-26mm				Y								
9006	24108	40	76	3-40mm	26x40mm	3-26mm				Y								
Geka 13/6	24109	28	58	3-28mm	22x28mm	3-19mm			Y									
Geka 8/40	24122	40	64	32-40mm	26x40mm	21-28mm			Y									
Alfra	24110	24	60	3-25mm	18x24mm	3-16mm							Y					
4014C	24123	24.4	84	6-24mm	16x24mm	8-17mm										Y		
Omera 13	24111	30	53	3-30mm	24x30mm	3-21mm											Y	
Omera 16	24112	35	68	3-35mm	26x35mm	3-24mm											Y	
Ficep 14	24115	28	50	3-28mm	22x28mm	3-19mm					Y							
Ficep 16	24116	30	72	3-30mm	24x30mm	3-21mm					Y							
23N/8	24119	10	38	2-20mm	5x10mm	3-7mm												Y
22N/16	24120	20	75	3-20mm	10x20mm	3-14mm												Y

\* Before 2002

Other shapes available



Offset punch & dies available



# Punch & Die Tooling

## Die Selection Chart

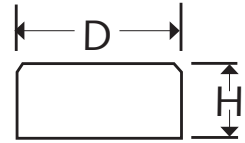

				Size range			Machine Brand											
				Round	Oblong (max)	Square	Sunrise	Mubea	Geka	Kingsland	Ficep	Peddinghaus	Alfra/Nitto/Promatech	Metalmaster	Marksman	Scotchman	Omera	Ertoma
Group 1	24201	30	15	3-15mm	10x15mm	3-10mm	Y*	Y							Y			
Group 2	24202	45	22.5	3-30mm	24x30mm	3-21mm	Y*	Y							Y	Y		
No.8	24221	60	32	3-40m	26x28mm	3-28mm	Y	Y	Y	Y				Y	Y			
Group 4	24204	80	40	40-50mm	28x50mm	28-35mm	Y	Y						Y				
210/13	24205	46	27	3-30mm	24x30mm	3-19mm	Y		Y			Y						
210/16	24206	50.8	26	3-31mm	24x30mm	3-22mm						Y				Y		
Alfra	24210	42	17	3-25mm	18x24mm	3-16mm												
Omera 13	24211	45	21	3-30mm	24x30mm	3-21mm							Y				Y	
Omera 16	24212	65	30	3-35mm	26x35mm	3-24mm											Y	
Ficep 13	24214	40	30	3-27mm	18x25mm	3-19mm					Y							
Ficep 14	24215	50	32.2	3-28mm	22x28mm	3-19mm					Y							
Ficep 16	24216	55	32	3-30mm	24x30mm	3-21mm					Y							
23N/8	24219	45	12	2-20mm	5x10mm	3-7mm												Y
22N/16	24220	55	18	3-20mm	10x20mm	3-14mm												Y

\* Before 2002

## How to calculate Die clearance

The following guide can be used as a die clearance guide when punching.

Material Thickness	mm	Up to 4	4 - 9.9	10 - 14.5	15 - 19.5	20 -24
Die Clearance	mm	0.2	0.7	1.2	1.7	2.2

Note: When you have determined the "Die Clearance" you require, you will need to add this amount to the punch size you are using: Refer example below

### Example 1:

Punch round                    Ø20mm  
 Material thickness            12mm  
 Die clearance                    1.2mm  
 Ø20mm + 1.2mm =            21.2mm  
 Die required                    21.2mm

### Example 2:

Punch square                    14x14mm  
 Material thickness            8mm  
 Die clearance                    0.7mm  
 14x14mm + 0.7mm =        14.7mm  
 Die required                    14.7x14.7mm

# Punch & Die Tooling

## Cropping Blades

Excision stocks and manufactures a large range of cropping blades for all punch & shear machines. Contact us with your requirements to learn more.

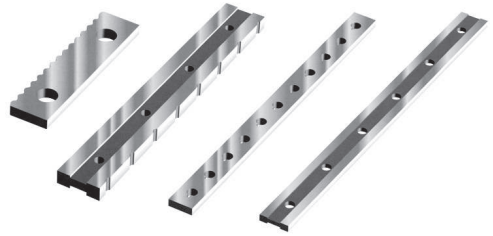

## Accessories

Excision offers a range of accessories from punch & die reducers and stripper blades. Contact us with your requirements to learn more.

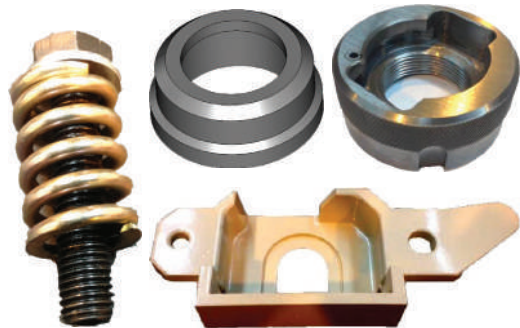

A perfect combination for all your punching and shearing works

## XDP825 Punch & Shear Oil

XDP825 is a high performance neat oil for medium and severe punch and shear operations. It's suitable for cutting ferrous (middle to high alloyed steel) and non-ferrous materials (Aluminium, copper and brass). Excellent performance due to the presence of Extreme-Pressure additives and very high refined mineral oils.

Size	Code
500ml	82825-500



# Punch & Die Tooling

## Custom Size Form

Punch & Die Specialist

Please complete and return. Thank you	
Company Name	
Address	
Telephone	
Email	
Contact Person	
Machine Type & Model	
Size of Punch & Dies Required	

Please add dimensions to the drawing below:

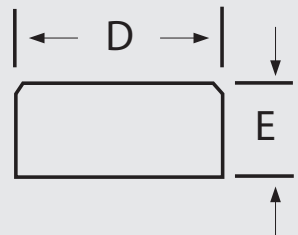
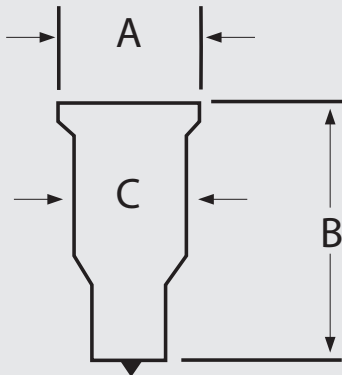

A	
B	
C	

D	
E	

Dimensions in mm.  
If you have more than one machine, please make a copy of this.



# Metal Cutting Machines





Accurate cutting of steel is only possible with precision machinery. Excision sources only the highest quality machinery for cutting steel. Working with world leading manufacturers to bring you the best machinery available.



# 122-135

Bandsaw Machines



# 136-140

Coldsaw Machines

E  
T

















info@excision.com.au  
+61 3 5551 4555

**Excision**<sup>®</sup>  
Dependable Precision

119

# Metal Cutting Machines







## Comparison Table







Model	 Cutting Capacity	 Cutting Capacity	 Cutting Capacity	Elec. Supply (Volt-Hz)	Blade Speed	Weight	Blade Size
 PHM 105	<b>0°</b> 105x93mm <b>45°</b> 70x60mm	<b>0°</b> 105mm <b>45°</b> 72mm	<b>0°</b> 102mm <b>45°</b> 68mm	240V	60/80 m/min	17kg	1335x13mm
 PHM 120	<b>0°</b> 120x115mm <b>45°</b> 85x70mm	<b>0°</b> 120mm <b>45°</b> 85mm	<b>0°</b> 119mm <b>45°</b> 80mm	240V	30-80 m/min Variable	17kg	1440x13mm
 PHM 205	<b>0°</b> 205x150mm <b>45°</b> 105x95mm	<b>0°</b> 152mm <b>45°</b> 106mm	<b>0°</b> 150mm <b>45°</b> 102mm	240V	60/80 m/min	38kg	1735x13mm
 210 PHW	<b>0°</b> 213x150mm <b>45°</b> 145x80mm	<b>0°</b> 175mm <b>45°</b> 140mm	<b>0°</b> 150mm <b>45°</b> 140mm	240V	60/80 m/min	59kg	2140x20mm
 180 PGM	<b>0°</b> 210x160mm <b>45°</b> 160x140mm	<b>0°</b> 180mm <b>45°</b> 140mm	<b>0°</b> 140mm <b>45°</b> 140mm	240V	25-90 m/min Variable	200kg	2310x20mm
 280 PGM	<b>0°</b> 240x220mm <b>45°</b> 165x125mm	<b>0°</b> 220mm <b>45°</b> 165mm	<b>0°</b> 220mm <b>45°</b> 145mm	240V	25-90 m/min Variable	250kg	2500x27mm
 280 PGD	<b>0°</b> 240x220mm <b>+/- 45°</b> 200x160mm	<b>0°</b> 220mm <b>+/- 45°</b> 165mm	<b>0°</b> 220mm <b>+/- 45°</b> 160mm	240V	25-90 m/min Variable	250kg	2500x27mm
 310 PGD	<b>0°</b> 310x170mm <b>+/- 45°</b> 240x205mm	<b>0°</b> 250mm <b>+/- 45°</b> 205mm	<b>0°</b> 170mm <b>+/- 45°</b> 205mm	415V	25-90 m/min Variable	480kg	3150x27mm
 500 PSM	<b>0°</b> 500x300mm <b>45°</b> 250x210mm	<b>0°</b> 300mm <b>45°</b> 300mm	<b>0°</b> 210mm <b>45°</b> 210mm	415V	25-90 m/min Variable	840kg	3850x27mm
 580 PSM	<b>0°</b> 530x330mm <b>45°</b> 350x300mm	<b>0°</b> 350mm <b>45°</b> 350mm	<b>0°</b> 330mm <b>45°</b> 330mm	415V	25-90 m/min Variable	1140kg	4350x34mm
 610 PSD	<b>0°</b> 610x310mm <b>+/- 45°</b> 400x340mm	<b>0°</b> 400mm <b>+/- 45°</b> 400mm	<b>0°</b> 380mm <b>+/- 45°</b> 380mm	415V	25-90 m/min Variable	1350kg	4780x34mm
 800 CSD	<b>0°</b> 800x460mm <b>+/- 45°</b> 500x460mm	<b>0°</b> 460mm <b>+/- 45°</b> 460mm	<b>0°</b> 460mm <b>+/- 45°</b> 460mm	415V	25-100 m/min Variable	2000kg	6000x41mm
 1050 CSD	<b>0°</b> 1050x560mm <b>+/- 45°</b> 680x500mm	<b>0°</b> 560mm <b>+/- 45°</b> 500mm	<b>0°</b> 560mm <b>+/- 45°</b> 500mm	415V	25-90 m/min Variable	3500kg	7140x54mm
 1250 CSS	<b>0°</b> 1250x800mm	<b>0°</b> 845mm	<b>0°</b> 800mm	415V	25-90 m/min Variable	7500kg	9180x67mm



# Metal Cutting Machines

## Comparison Table

Bianco Bandsaw Machines Stocked at Excision							
Model	Cutting Capacity 	Cutting Capacity 	Cutting Capacity 	Power Supply	Blade Speed	Weight	Blade Size
280M 60G 	0°260x140mm 45°160x140mm	0°220mm 45°160mm	0°220mm 45°155mm	415V	35-70 m/min Variable	240kg	2450x27mm
420M 60G 	0°420x200mm 45°270x140mm	0°300mm 45°240mm	0°240mm 45°230mm	415V	35-70 m/min Variable	356kg	3270x27mm
330 A60 	0°330x120mm 45°200x130mm	0°260mm 45°200mm	0°240mm 45°190mm	415V	35-70 m/min Variable	1090kg	3010x27mm
370 A60 	0°330x240mm 45°230x140mm	0°280mm 45°225mm	0°240mm 45°215mm	415V	35-70 m/min Variable	1090kg	3120x27mm

Excision Coldsaw Machines						
Model	Cutting Capacity 	Cutting Capacity 	Cutting Capacity 	Power Supply	Blade Speed	Blade Size
315 SMD 	0°120x60mm 45°90x60mm	0°105mm 45°90mm	0°85mm 45°80mm	240V 415V	40 RPM 20/40 RPM	315x32mm
350 SMD 	0°120x80mm 45°90x90mm	0°115mm 45°110mm	0°100mm 45°90mm	240V 415V	40 RPM 20/40 RPM or 40/80 RPM	350x32mm
350 VMD 	0°120x80mm 45°90x90mm	0°115mm 45°110mm	0°100mm 45°90mm	240V	20-80 RPM Variable	350x32mm

# Metal Cutting Machines

## PHM 105 - Portable Bandsaw

Small, light and easy to carry. 105mm capacity, ideal for cutting up to 100x100 RHS on site. 2-speed motor for ferrous and non-ferrous metals. Quality saw made in Italy.



Code 4105PHM

PHM 105 Cutting Capacity			
0°	105 x 93mm	105mm	102 x 102mm
45°	70 x 60mm	72mm	68 x 68mm
Power Supply	240V		
Blade Speed	60/80 m/min		
Weight	17kg		
Blade Size	1335 X 13mm		



Saw is compatible with table for cutting radius.

## PHM 120 - Portable Bandsaw

Light weight and easy to carry bandsaw with large 120mm capacity. Variable speed motor with huge range from 30-80m/min meaning you can cut very hard steels to non ferrous materials. Quality saw made in Italy.

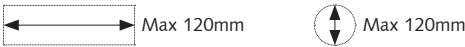

Code 4120PHM

120 PHM Cutting Capacity & Specification			
0°	120x115mm	120mm	119 x 119mm
45°	85x70mm	85mm	80 x 80mm
Power Supply	240V		
Blade Speed	30-80 m/min		
Weight	17kg		
Blade Size	1440x13x0.65		



# Metal Cutting Machines

## PHM 205 - Portable Bandsaw

Very large capacity portable saw that can cut 100x100 RHS at 45 degrees. 2-speed motor for cutting ferrous and non-ferrous metals. Quality saw made in Italy.

SCAN TO GO TO LINK



Code 4205PHM

205 PHM Cutting Capacity & Specification			
0°	205x150mm	152mm	150 x 150mm
45°	105x95mm	106mm	102 x 102mm
Power Supply	240V		
Blade Speed	60/80 m/min		
Weight	38kg		
Blade Size	1735x13x0.9		



## 210 PHW - Portable Bandsaw

Largest capacity portable saw on the market. Due to the large wheels it is easy to move around on worksites. It uses a large 20mm wide bandsaw blade enabling straighter cuts and also larger range of cutting capabilities.

SCAN TO GO TO LINK

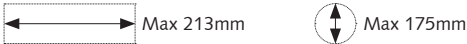

Code 4210PHW

210 PHW Cutting Capacity & Specification			
0°	205x150mm	175mm	150 x 150mm
45°	145 x 80mm	140mm	140 x 140mm
Power Supply	230V		
Blade Speed	60/80 m/min		
Weight	59kg		
Blade Size	2140x19x0.9		



# Metal Cutting Machines

## 180 PGM Bandsaw



The PGM180 is a strong and well built saw made for smaller applications like thin walled pipe and RHS. It has a very strong bow and carbide guides so will also cut solids and all profiles of steels and other materials.





### Features

- Up to 60° mitre cutting
- Quick lock vice
- Electric coolant pump
- Cast iron saw frame
- Carbide blade guides
- Includes stand, infeed roller, 500mm adjustable end stop & one blade fitted



Code 401180PGM1

180 PGM Cutting Capacity			
			
0°	180 X 210mm	180mm	180mm
45°	135 X 140mm	140mm	140mm
60°	80 X 90mm	80mm	80mm
Power Supply	240V		
Blade Speed	25-90 m/min		
Weight	200kg		
Blade Size	2310 X 20 X0.9mm		



When changing blades use gloves  
- Page 30



**Gloves**



# Metal Cutting Machines

## 280 PGM Bandsaw



The PGM280 is the Australian workhorse of bandsaws. It is the most common Excision bandsaw on the market due to its dependable build and capabilities. It has carbide guides and a strong bow to guarantee precision straight cuts every time. Also has easy access panel at the front of the saw.

### Features

- Up to 60° mitre cutting
- Quick lock vice
- Electric coolant pump
- Variable-speed 25-100m/min
- Cast iron saw frame
- Carbide blade guides
- Includes stand, infeed roller, 500mm adjustable end stop & one blade fitted



Code 401280PGM1

280 PGM Cutting Capacity			
0°	240 X 220mm 250 X 150mm	220mm	220mm
15°	230 X 220mm 250 X 115mm	220mm	220mm
30°	210 X 150mm 220 X 100mm	220mm	205mm
45°	165 X 125mm	165mm	145mm
60°	105 X 80mm	105mm	80mm
Power Supply	240V		
Blade Speed	25-90 m/min		
Weight	260kg		
Blade Size	2500 X 27 X0.9mm		



Swarf free workplace



**Swarf Remover**

# Metal Cutting Machines

## 280 PGD Bandsaw



The Excision 280PGD is the fabricators favorite saw due to the ease of use dual mitre and dependable strong build. It has carbide guides and a reinforced strong bow to guarantee straight precision cuts.

### Features

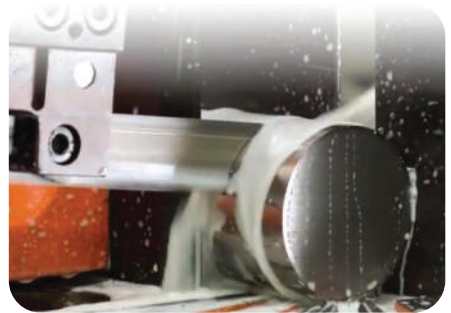
- Dual mitre 60° to -45°
- Electric coolant pump
- Cast iron saw frame
- Carbide blade guides
- Includes stand, infeed roller, 500mm adjustable end stop & one blade fitted



Code 401280PGD1

280 PGD Cutting Capacity			
			
0°	240 X 220 250 X 150	220mm	220mm
45°	200 X 160	165mm	160mm
60°	200 X 95	105mm	95mm
-45°	200 X 160	160mm	160mm
Power Supply	240V		
Blade Speed	25-90 m/min		
Weight	260kg		
Blade Size	2500 X 27 X 0.9mm		



Wanting to increase your blade life? Why not try Excision coolant?

**XDP1000**





# Metal Cutting Machines

## 310 PGD Bandsaw



This bandsaw has been designed for rugged and tough conditions of a fabrication and engineering workshop.

### Features

- Easy to use control panel
- Electric coolant pump
- Heavy Duty direct drive gear box
- Carbide blade guides for straighter cuts and longer blade life
- Low working height - only 730mm



Code 401310PGD3

310 PGD Cutting Capacity			
			
0°	250 X 310	250mm	250mm
45°	190 X 250	190mm	190mm
60°	120 X 140	120mm	120mm
-45°	100 X 250	180mm	150mm
Power Supply	415V		
Blade Speed	25-90 m/min		
Weight	480kg		
Blade Size	3150 X 27 X 0.9mm		



SCAN TO GO TO LINK



Did you know that blade tension solves 90% of all Bandsaw Blade Problems? Check your tension with our new gauge - Page 30





**Blade Tension Gauge**

# Metal Cutting Machines

## 500 PSM Semi-Auto Bandsaw

The 500PSM Semi-Automatic is a very well built dependable bandsaw made for large jobs and all day use. Very easy to use automatic downfeed and return. It has a large jaw opening of 500mm and up to 60 degree mitreing.

Code 4380415

PSM 500 Cutting Capacity			
			
90°	500 X 300	300mm	300mm
45° L	400 X 250	290mm	250mm
60° L	300 X 220	180mm	160mm
Power Supply	415V		
Blade Speed	25 - 90 m/min		
Weight	840kg		
Blade Size	3850 X 27 X 1.1mm		



### Features



- Full semi automatic
- Hydraulic vice
- Hydramechanical blade tension
- Automatic bow return & vice release at end of cut



## 580 PSM Semi-Auto Bandsaw

The 580PSM Semi-Automatic is a very well build dependable bandsaw made for large jobs and all day use. Very easy to use automatic downfeed and return. It has a large jaw opening of 580mm and up to 60 degree mitreing.

Code 4400415

PSM 580 Cutting Capacity			
			
90°	580 X 400	400mm	400mm
45° L	350 X 400	350mm	350mm
60° L	170 X 400	170mm	170mm
Power Supply	415V		
Blade Speed	25 - 90 m/min		
Weight	1140kg		
Blade Size	4350 X 34 X 1.1mm		



### Features

- Full semi automatic
- Hydraulic vice
- Hydramechanical blade tension
- Automatic bow return & vice release at end of cut







# Metal Cutting Machines

## 610 PSD Semi-Auto Bandsaw



The Excision 610 PSD is a large dependable saw made for all serious fabricators - it is dual mitre making it very easy to cut accurate angles on large pieces of steel. Easy access control panel.



### Features

- Large capacity double mitre
- Full semi automatic
- Hydraulic Vice
- Automatic bow return & vice release at end of cut.

Code 401610PSD3

610 PSD Cutting Capacity			
			
0°	400x616mm	400 mm	400 mm
45°	350x400mm	350 mm	350 mm
60°	200x400mm	200 mm	200mm
-45°	350x400mm	350 mm	350mm
Power Supply	415V		
Blade Speed	25 - 90 m/min		
Weight	1350 KG		
Blade Size	4780 x 34 x 1,1 mm		



Install a MQL spray mist to dry cut see page 71



# Metal Cutting Machines

## 800 CSD Semi-Auto Bandsaw

The 800 CSD is a very well built strong saw with dual columns made for cutting large structural and solid materials. The large capacity of 460x800 gives the saw many capabilities especially for the serious fabricators and engineers.

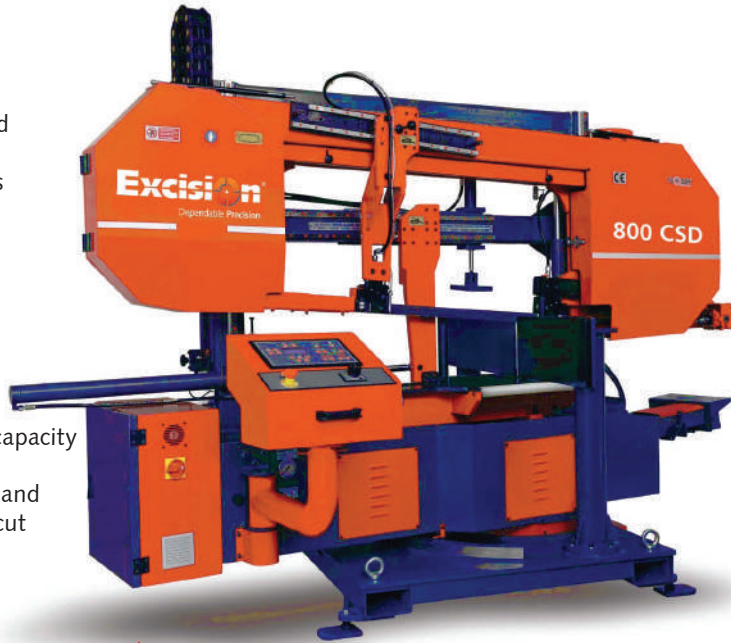



### Features

- Full semi automatic
- Dual mitre with large capacity
- Dual column
- Automatic bow return and vice release at end of cut



Code 401800CSD3

### 800 CSD Cutting Capacity

			
0°	460 X 800	460mm	460mm
30°	460 X 650	460mm	460mm
45° L	460 X 500	460mm	460mm
60° L	460 X 300	300mm	300mm
Power Supply	415V		
Blade Speed	25 - 100 m/min		
Weight	2000kg		
Blade Size	6000 X 41 X 1.3mm		



Lift your steel safely with



**Magnetic Lifters**

## 1050 CSD Semi-Auto Bandsaw

The 1050 CSD is a very large dual column bandsaw machine. Vice opening of 1050mm allows cutting of large welded beams, and other large work-pieces. Heavy fabrication and engineering is made possible with this machine.





### Features

- Full semi automatic
- Dual mitre with large capacity
- Dual column
- Automatic bow return and vice release at end of cut



Code 401050CSD3

1050 CSD Cutting Capacity			
			
0°	560 X 1050	560mm	560mm
30°	540 X 850	560mm	560mm
45° L	540 X 680	560mm	560mm
60° L	540 X 400	400mm	400mm
Power Supply	415V		
Blade Speed	25 - 100 m/min		
Weight	3500kg		
Blade Size	7140 X 54 X 1.6mm		



**Best Match**

Install a MQL spray mist to dry cut see page 71



**MQL Spray**

# Metal Cutting Machines

## 1250 CSS Semi-Auto Bandsaw

CSS1250 model is a semi automatic bandsaw machine with double column body design. The Machine is designed for straight cutting. Precision cutting capability has been gained with linear guides. The cut material can be easily tightened thanks to hydraulic vises. Feeding material is manual.



SCAN TO  
GO TO LINK



Code 501250CSS3

1250 CSS Cutting Capacity			
0°	1250 x 800 mm	845 mm	800 mm
Power Supply	415V		
Blade Speed	25 - 90 m/min		
Weight	7,500 kg		
Blade Size	9,180 x 67 x 1.6mm		

Cutting packs of steel? Use only Bi-alfa Profile blades.

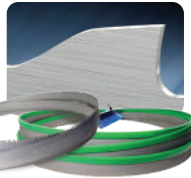

**Bi-Alfa Profile Blades**



# Metal Cutting Machines

## Bianco 280M 60G Bandsaw

High quality Italian made bandsaw.

### Features

- Gravity downfeed
- Hardened aluminium bow
- Gravity downfeed over hydraulic brake
- Base with welded structure
- Carbide blade guides

Code	4280M60G		
<b>280 60G Cutting Capacity</b>			
			
90°	260 X 140	220mm	220mm
45° R	160 X 140	160mm	155mm
60° R	95 X 95	95mm	95mm
Power Supply	415V		
Blade Speed	35 - 70 m/min		
Weight	240kg		
Blade Size	2450 X 27 X 0.9mm		





## Bianco 420M 60G Bandsaw

Large capacity manual saw with gravity downfeed. High quality Italian made machine.

### Features

- Gravity downfeed
- Base with welded structure
- Hardened aluminium bow
- Carbide blade guides
- Gravity downfeed over hydraulic brake

Code	4420M60G		
<b>420M 60G Cutting Capacity</b>			
			
90°	420 X 180	300mm	260mm
45° R	250 X 180	240mm	230mm
60° R	170 X 170	170mm	170mm
Power Supply	415V		
Blade Speed	35 - 70 m/min		
Weight	356kg		
Blade Size	3270 X 27 X 0.9mm		



# Metal Cutting Machines

## Bianco Automatic Bandsaw



Fully automatic Bianco saw available in NC and CNC. Ideal for all cutting applications from repetition to once off cuts. Save time and labor with a fully automatic saw.





### Features

- Full PLC control
- Hitch feed accuracy +/- 0.2mm
- Hardened aluminium bow
- Carriage travel 600mm
- Carbide adjustable blade guides
- Automatic fast up/down bow control
- Adjustable pressure according to cutting resistance
- Material feed with transversal oscillation to facilitate feed of crooked bar

Code	4330A60
------	---------

330 A60 Cutting Capacity			
			
90°	330 X 140	260mm	220mm
45° R	200 X 130	200mm	190mm
60° R	120 X 100	120mm	115mm
Power Supply	415V		
Blade Speed	35 - 70 m/min		
Weight	1090kg		
Blade Size	3010 X 27 X 0.9mm		

Code	4370A60
------	---------

370 A60 Cutting Capacity			
			
90°	370 X 240	280mm	240mm
45° R	230 X 140	255mm	215mm
60° R	140 X 130	140mm	140mm
Power Supply	415V		
Blade Speed	35 - 70 m/min		
Weight	1090kg		
Blade Size	3120 X 27 X 0.9mm		

# More **BIANCO** models available!



SCAN TO  
GO TO LINK

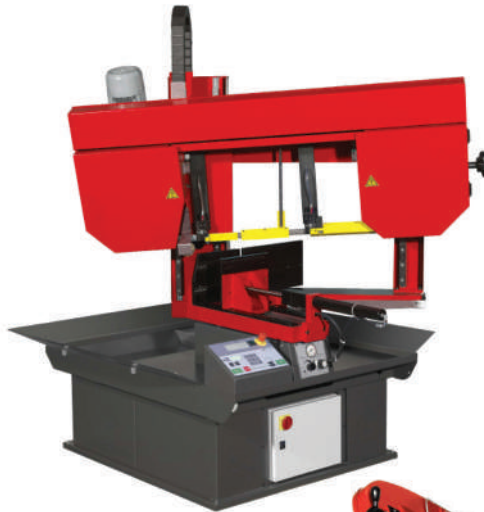

# Metal Cutting Machines

## Excision Coldsaw Machines

Introducing the new Excision coldsaw machine range. Quality European engineering at an affordable price

The new Excision Coldsaw range offers premium European engineering for all your coldsaw cutting needs, from the economical 315 SMD model to the truly versatile 350 VMD with variable speed.

### All machines feature:

- Strong and robust gearbox
- Self-centering vice system protecting your work pieces
- Quality electric coolant pump
- Square-thread vice screw for quick self-locking



### The new Excision Coldsaw Range will

- Allow you to cut through any steel configuration
- Give you longer blade life due to ultra low vibration
- Provide smoother, straighter cuts

## 315 SMD Coldsaw

### Benefits

- Value for money
- Smooth cuts at and versatility
- European engineering without the premium price tag

315 SMD Cutting Capacity			
			
0°	120 X 60	105mm	85mm
45°	90 X 60	90mm	80mm
Code		402315SMD1	402315SMD2
Power Supply		240V	415V
Blade Speed		40rpm	20 & 40rpm
Blade Size		315mm	







# Metal Cutting Machines

## 350 SMD Coldsaw



SCAN TO GO TO LINK



### Benefits:

- Dual Mitre Swivel for optimum flexibility
- Ability to cut a wide range of materials including ferrous and non-ferrous metals
- Superior gear box gives you smooth consistent cuts.



350 SMD Cutting Capacity			
0°	120 X 80	115mm	100mm
45°	90 X 90	110mm	90mm
Code	402350SMD1	402350SMD2	402350SMD3
Power Supply	240V	415V	415V
Blade Speed	40rpm	20 & 40rpm	40 & 80rpm
Blade Size	350mm		



Fixed back vice available for all models

## 350 VMD Coldsaw The Variable Speed

### Benefits:

- Truly versatile: Variable speed function allows cuts from non-ferrous to hardened steels
- European engineering at its best – superior reliability
- Unsurpassed cutting performance giving longer blade life



350 VMD Cutting Capacity			
90°	370 X 240	280mm	240mm
45°	230 X 140	255mm	215mm
Code	402350VMD1		
Power Supply	240V		
Blade Speed	20 - 80rpm		
Blade Size	350mm		



SCAN TO GO TO LINK



# Metal Cutting Machines

## **350P Coldsaw** Pneumatic Vice



The Pneumatic vice made for fast and easy cutting of pipe and RHS.

### Features

- Automatic pneumatic powered vice - saves time and labour. The vice closes as soon as you start the motor via the trigger handle



### 350P Cutting Capacity

			
0°	120 X 80	115mm	100mm
45°	90 X 90	110mm	90mm
Code	402350PSMD2	402350PVMD1	
Power Supply	415V	240V	
Blade Speed	20 & 40rpm	20 - 80rpm	
Blade Size	350mm		



Swarf free workplace



**Swarf Remover**



# Metal Cutting Machines

## 350 ASM Automatic Coldsaw



### Features

- Fully automatic machine for straight tube cutting
- Servo motor controlled material feeding system with ball screw
- Hydro-pneumatic operation of saw head smooths descent for optimum cut
- PLC controlled colour type touchscreen display
- Up to 1m hitch feed
- High performance gear box designed in accordance with continuous working conditions (helical gears and worm gear set)
- 2 speed main motor
- Coolant tank with box to collect chips and electrical lubrication pump for blade lubrication and cooling



350 ASM Cutting Capacity			
0°	120 X 80	115mm	110mm
Code	402350ASM3		
Power Supply	415V		
Blade Speed	40 & 80rpm		
Blade Size	350mm		



Try coated HSS blades for faster and longer blade life

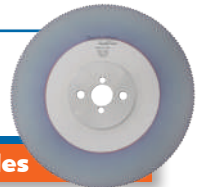

**Coldsaw Blades**



# Metal Cutting Machines

## 400 APD Aluminium Saw

Dependable precision portable saw, suitable for cutting aluminium, wood, or PVC. Can also be bench mounted.

### Features

- Safe cutting with double spring system and saw barrier
- Cast core with impact resistance
- Cutting at any desired angle between  $-45^{\circ}$  and  $+45^{\circ}$
- Cutting at  $0^{\circ}$ ,  $15^{\circ}$ ,  $22.5^{\circ}$ ,  $30^{\circ}$ ,  $45^{\circ}$  right and left fixed angles

400 APD Cutting Capacity			
			
$0^{\circ}$	170 X 105	105mm	105mm
$45^{\circ}$	110 X 105	105mm	105mm
Code	405400APD3		
Power Supply	415V		
Blade Speed	3000rpm		
Blade Size	400 X 30-32mm		





## 400 AMD Aluminium Saw

Dependable precision manual saw for aluminium, wood or PVC.

### Features

- Safe cutting with double spring system and saw barrier
- Cast core with impact resistance
- Cutting at any desired angle between  $-45^{\circ}$  and  $+45^{\circ}$
- Cutting at  $0^{\circ}$ ,  $15^{\circ}$ ,  $22.5^{\circ}$ ,  $30^{\circ}$ ,  $45^{\circ}$  right and left fixed angles
- Manual cutting process and operating system
- Pneumatic vertical and horizontal clamps

400 AMD Cutting Capacity			
			
$0^{\circ}$	170 X 105	105mm	105mm
$45^{\circ}$	110 X 105	105mm	105mm
Code	405400AMD3		
Power Supply	415V		
Blade Speed	3000rpm		
Blade Size	400 X 30-32mm		



# Metal Cutting Machines

## 300 ALS Automatic Length-stop Table

Dependable Precision automatic length-stop table for cutting precise lengths of any material. Complex cutting or job lists including varying lengths can be easily loaded or programmed into the easy-to-use touch screen control panel. Suitable for use on saws, ironworkers and punching lines.



### Features

- 3m Idle table
- 3m table stop
- Touch screen for easy use
- Has manual, semi-auto and fully-auto settings
- Unlimited number of programs
- Modular for easy shipping and set-up
- 240V



Perfect match for  
PGM Bandsaw, SMD  
& VMD Coldsaws and  
the 400 AMD



# Metal Preparing **Machines**





Excision stocks an extensive range of metal preparing machines from plate bevelers to punching units. Whether you have small pieces or large plates we have your weld/paint prep sorted.



**144-156**

Bevel Milling Machines

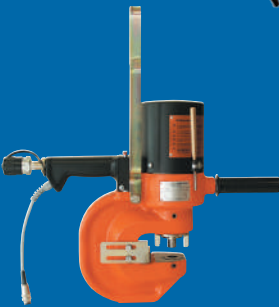

**157**

Hydraulic Pump & Punch Machines

# Metal Preparing Machines

## **KFK 2 Portable Beveler** Max. bevel width: 2mm

### Features

- Compact design, great ergonomics
- Weight only 400 g / 0.88 lb
- Edge machining by rounding R1.5 mm / 0.06 in - edge preparation before painting
- Powerful and reliable pneumatic drive
- Precision machining scale for more precise machining



Code	24200
Technical Data	
Bevel Angle	45°
Bevel Width	0-2mm
Speed	23,000 RPM
Feed	Manual
Weight	400 g
No. of Cutting Tips	3 pcs

Description	Code
Standard Cutting Insert	24201
Heavy Duty Cutting Insert	24204
Radius Cutting Insert R1.5mm	24202







# Metal Preparing Machines

## **KB 3 Bench Beveler** Max. bevel width: 3mm

Designed for deburring and beveling of steel parts and workpieces. Processing of different types of materials. Solid and stable machine design.



### Features

- For steel, stainless steel, aluminum and other materials
- Scale for machining depth adjustment
- Protective safety covers
- Adjustable machining angle



Code	28220
<b>Technical Data</b>	
Bevel Angle	30° - 60° continuously adjustable
Bevel Width	0 - 3 mm
Power Supply	415V
Speed	3600 RPM
Feed	Manual
Weight	31 kg
No.of Cutting Tips	5 pcs (four-sided)

<b>Description</b>	<b>Code</b>
Cutting Insert	25909

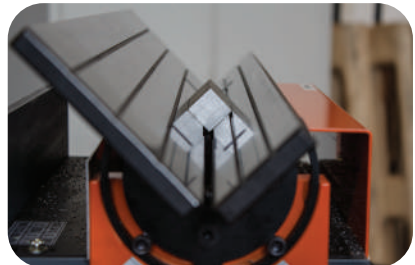

# Metal Preparing Machines

## **KFK 5 Portable Beveler** Max. bevel width: 5mm

- Extremely high powered 1530w motor
- 4,200-11,000 RPM with soft start and thermal overload protection
- Includes: transport case, 45° milling head and inserts, 1 set of tools
- 45° bevel angle with optional 30° and radius (2.5mm)
- 5mm max bevel (depending on material)
- Light weight and portable - only 4kg



Code	25950
Technical Data	
Bevel Angle	30° or 45°
Bevel Width	0 - 5 mm
Power Supply	240V
Speed	4,200-11,000 RPM
Weight	4 kg



Description	Code
Standard Insert	25206
Heavy Duty Insert	25209
2.5mm Radius Insert	25205
30° Insert Holder	25203
45° Insert Holder	25202

# Metal Preparing Machines

## **KFK 10 Portable Beveler** Max. bevel width: 10mm

Designed for bevelling and deburring workpieces, internal and external radiuses and holes. Specially designed for producing bevels and welding preparation. Durable and stable machine design without compromises.



### Benefits:

- User friendly - bigger bevel with lightweight machine
- Electronic speed control for bevelling different materials
- Extremely high powered 1700W motor

Code	25310
Technical Data	
Bevel Angle	30°, 37°, 35°, 45°, 50°, 60° - other angles on demand
Bevel Width	0 to 10mm
Power Supply	240V
Speed	2700 - 8500 RPM
Weight	6 kg

Description	Code
30° Milling Head	27223
45° Milling Head	27222
60° Milling Head	27240
Cutting Insert 15mm	28015
Cutting Insert 8mm	28008
Screw	28007



# Metal Preparing Machines

## **KFK 15 Portable Beveler** Max. bevel width: 15mm

Designed for bevelling and deburring of parts, internal and external radiuses and holes. Specially designed for producing visual bevel and welding preparation. Powerful electric drive for extreme loads.

### Benefits:

- Bevelling workhorse - large bevels with portable machine
- Swivel ergonomic handle for ease of use
- Extremely high powered 2500W motor



Code	25315
Technical Data	
Bevel Angle	30°, 37°, 5°, 45°, 50°, 60° - other angles on demand
Bevel Width	0 to 15 mm
Power Supply	240V
Speed	6600 RPM
Weight	9.5 kg

Description	Code
30° Milling Head	27223
45° Milling Head	27222
60° Milling Head	27240
Cutting Insert 15mm	28015
Cutting Insert 8mm	28008
Screw	28007





# Metal Preparing Machines

## **KS 22 Portable Beveler** Max. bevel width: 22mm

Designed for bevelling and deburring straight edges, for cleaning and removing an unwanted layer of materials on the workpiece edge resulting from cutting the metal sheet by burning. Specially designed for the production of visual bevels and welding preparation. Powerful electric drive for extreme loads.

### Benefits:

- High performance motor
- Continuously adjustable working angle from 0° - 60°
- The machine is able to perform cleaning - machining edges under angle 0° to remove unwanted material layer after plasma or oxygen cutting.
- Very compact and ergonomic design allows high productivity during work.
- Unique bevel size adjustment mechanism increases accuracy of the work.
- Circumferential protection frame protects the machine in case of fall and allows more options on how to grip the machine while working.
- With tube accessory can bevel pipes and tubes to Ø 600mm.



<b>Code</b>	<b>29200</b>
<b>Technical Data</b>	
Bevel Angle	continuously adjustable between 0 - 60°
Bevel Width	0 to 22 mm
Power Supply	240V
Speed	2850 RPM
<b>Weight</b>	<b>19.5 kg</b>
<b>Description</b>	<b>Code</b>
Cutting Inset	29203



# Metal Preparing Machines

## KA 12 Auto Beveler Max. bevel width 12 mm

The KA 12 is one of the lightest bevelling machines with automatic feed in the market. Thanks to its compact size and low weight it is perfect not only for workshops but also for assembly lines. The quietest bevelling system on the market.



### Benefits:

- For conventional steel (up to strength of 600 MPA / 87 022 PSI), brass, copper and aluminum materials
- For bevelling material with minimum dimensions - width 65 mm, length 60 mm thickness 3 mm
- Thickness of bevelled material 3-35mm
- Bevelling of pipes from the internal 95mm
- Variable bevel angle with replaceable arms/kits for each given angle



Code	1918
Technical Data	
Bevel Angle	continuously adjustable between 0-60°
Bevel Width	0 - 12 mm
Power Supply	415V
Speed	2850 RPM
Feed	1,8 m/min.
Weight	31 kg
Description	Code
Shearing Knife Eco	1927
Shearing Knife Premium	1916





# Metal Preparing Machines

## KA 15 Auto Beveler Max. bevel width of 15 mm

The KA 15 machine is one of the fastest bevelling machines with the automatic feed on the market. It is suitable not only for workshops, but also for assembly operations. It has a continuous working angle adjustment system. In addition, the machine is equipped with automatic feed.

### Benefits:

- KA 15 creates welding-ready bevels on linear plates of any shearable material, including iron, steel, stainless steel, brass, copper, and aluminium.
- It cuts bevels in steel 5 to 40 mm in thickness, with a minimum plate width of 70 mm and minimum plate length of 150 mm.
- The beveling angle adjusts continuously from 15° to 50° without replacing any parts.
- Inversion allows for the creation of a double-sided bevel - no need to rotate or flip heavy material



Pictured with Manipulator

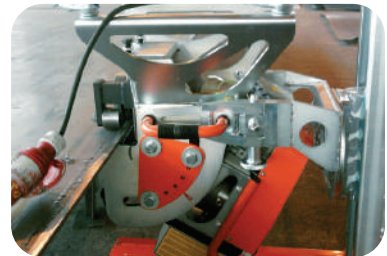

Code	25950	
<b>Technical Data</b>		
Bevel Angle	continuously adjustable between 15° - 50 °	
Bevel Width	0 -15 mm	
Power Supply	415V	
Feed	3,5 m/min.	
Weight	94 kg	
<b>Description</b>		<b>Code</b>
Shearing Knife Eco		2137
Shearing Knife Premium		2142

# Metal Preparing Machines

## KA 18 Auto Beveler Max. bevel width 18 mm

The KA 18 machine is one of the most powerful bevelling machines with automatic feed on the market. It is suitable not only for workshops, but also for an assembly on-site. It has a continuous working angle adjustment system. Thanks to the special design of the drive system, the KA 18 is also suitable for tougher materials. The machine is equipped with automatic feed.

### Benefits:

- For bevelling material with minimum dimensions - width 70 mm, length 150 mm, thickness 6 mm
- Thickness of bevelled material 6 - 40 mm.
- The bevel angle is easily adjustable from 15° to 50° - smoothly, without the need to replace any part.



Code	1980
Technical Data	
Bevel Angle	continuously adjustable between 15° - 50°
Bevel Width	0 - 18 mm
Power Supply	415V
Feed	3,5 m/min.
Weight	94 kg

Description	Code
Shearing Knife Eco	2137
Shearing Knife Premium	2142







# Metal Preparing Machines

## KA 29 Auto Beveler Max. bevel width 29 mm

KA 29 machine is one of the largest and most powerful machines in the field of rotary cutting bevelling machines. The machine is equipped with an automatic feed and can be used as a stationary machine designed for large and small workpieces. At the same time it can be used as a mobile bevelling system when the machine moves along the machined steel sheet at a rate of almost two meters per minute. The KA 29 machine is capable of machining both, standard and stainless steel. The machine has a low noise drive reducing the noise at the workplace.



### Benefits:

- For conventional steel (up to strength 700 MPa / 101 526 PSI), stainless steel, brass, copper and aluminum materials
- The bevelled material thickness 6 to 60 mm
- Variable bevel angle with replaceable arms/ kits for each given angle
- Double-sided bevel (X, K), without any need for material handling

Code	1962
<b>Technical Data</b>	
Bevel Angle	30°, 45°, 22.5°, 37.5°, 50°
Bevel Width	0 - 29 mm
Power Supply	415V
Feed	1.8 m/min.
Weight	205 kg

Description	Code
Shearing Knife Eco	1970
Shearing Knife Premium	1971



# Metal Preparing Machines

## KA 30 Table Beveler Max. bevel width 30 mm

Stationary KA 30 is one of the best solutions for bevelling large volumes of small workpieces or long, narrow steel strips. KA 30 can be used not only for bevelling, but also for deburring. Thanks to the unique geometry of the cutter the feed rate can be set up to the speed of 3.5 m/min. For longer workpieces it is possible to equip the machine with an additional input and output table which extends the workspace to remarkable 2 824 mm.



### Benefits:

- The machine designed for bevelling steel, aluminum, copper and other materials
- Bevelling by milling - high quality bevel (mirror finish)
- Optional accessories for pipe bevelling

Code	25999
Technical Data	
Bevel Angle	continuously adjustable between 15° - 50°
Bevel Width	0 - 15 mm
Power Supply	415V
Feed	3,5 m/min.
Weight	94 kg
Description	Code
Cutting Insert	25907

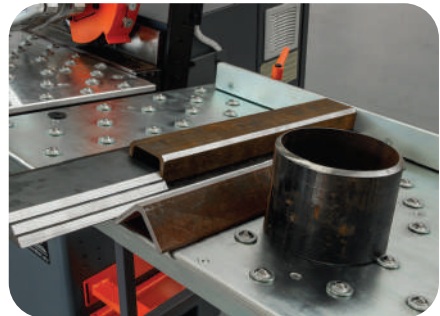



# Metal Preparing Machines

## KA 50 Auto Beveler Max. bevel width 62 mm

Bevelling system KA 50 is another of the series of unique solutions. Basically, three beveling systems are combined in a single machine. KA 50 can be used as a mobile beveller, which moves along the beveled material at the speed up to 1.2m/min. The range of the beveling angle is 15-60 Degrees. It is possible to flip the entire machining unit upside down for beveling the underside of the material. This is made possible with the Manipulator (page 156) which comes standard with the machine.



### Benefits:

- Automatic feed with continuous adjustment of the feed rate in the range of 0-1.2m/min
- High speed milling tool equipped with cutting inserts with extended life
- The variable adjustment of the desired angle in the range 15 -60 Degrees without having to replace any parts
- All electronic equipment is closed in the dust-tight cabinet with increased vibration resistance
- Equipped with the most modern safety features



Code	1940
<b>Technical Data</b>	
Bevel Angle	15° - 60° (continuous)
Bevel Width	0-62mm/15degrees 0-50mm/45degrees
Power Supply	415V
Feed Speed	0 - 1,2 m/min.
Weight	202 kg

Description	Code
Cutting Insert	1945



# Metal Preparing Machines

## Accessories for Bevelers

Description	Code	KFK 10/15	KA Models	Part Image
<p><b>Dock Station:</b></p> <p>Dock station enables the KFK models to be used stationary. It is designed for beveling small workpieces which would be hard or impossible to clamp and bevel the standard way. The system retains all advantages of the hand-held machines. The Dock system makes it possible to bevel irregular shapes, straight workpieces and holes. Radius edges are also possible with the radius milling head. Specialty guide attachments and an easy, vertical worktable adjustment allow for beveling of pipe and tube.</p>	25350	●		
<p><b>Pipe Beveler Attachment:</b></p> <p>Beveling tool for easy and fast machining of pipes from Ø 95 mm (3.75"). The maximum diameter of the pipe is not limited, and the tool can be used on flat materials. The unique mechanism of clamping, guiding rollers ensures precise and comfortable guiding around the circumference of the machined pipe or along the edge of the sheet metal. The robust frame of the body of the tool guarantees constant cut with a minimum of possible vibrations and uncompromising stability of the selected bevel angle.</p>	25500	●		
<p><b>Manipulator:</b></p> <p>Manipulator provides a simple, quick turn the KA models of 180° for create double-sided bevels XK. The operator does not need a crane to rotate of material. There is significant time-saving at work. The beveler is "floating" on the MANIPULATOR and compensates unevenness of the floor</p>	1930		●	



# Metal Preparing Machines

## APS 120

### Features

- Punch diameter up to 25mm
- Max material thickness 16mm
- Only 35kg
- Punching power 44 t
- Includes: control cable, hydraulic hose (5m), tools, depth fence, suspension hook, one punch & die Set (ø22mm)

Code	23004
------	-------

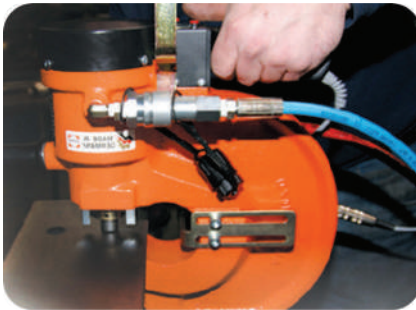

Excision has a complete range of Punch & Die tooling

**Punch & Dies**



## Pump AHP-M

### Features

- Suits all APS single acting models
- Max. Pressure: 700 bar
- Max. Pumping Capacity: 1.1 l/min
- Weight: 29kg
- Operating Voltage: 230V / 50Hz

Description	Code
PUMP AHP-M	23189





## Industrial Clamps

Excision Xtreme clamps are unique in performance. They achieve extreme force with minimal effort.



10% More Force than ordinary clamps

Up to 70%

The diagram shows a blue circle with a white arrow pointing down and another pointing up, meeting at a central point. From this point, several white lines radiate outwards, suggesting force or pressure. The text '10% More Force than ordinary clamps' is written in a white arc around the top of the circle. Below the circle is an orange circle containing the text 'Up to 70%' in white.

# Industrial Clamps

## Excision FX Xtreme Clamp

### Features

- Xtreme force - Less effort
- Lifetime guarantee
- Patented Design - improved performance through innovation
- Internal ball bearing mechanism - no resistance for optimal performance
- Hardened steel bar brake for a braking system of total confidence.
- Permanent lubrication - lifetime guarantee
- Trapezoidal thread - increased efficiency
- Totally sealed - longer tool life



# Industrial Clamps

## FX Xtreme Clamp

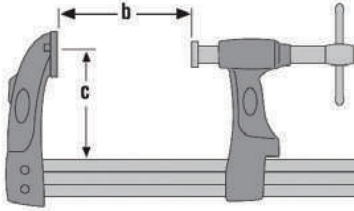

- Powerful clamping force with less effort
- High precision clamping
- Hardened steel bar brake
- Trapezoidal thread - totally sealed and permanently lubricated
- Suited to all environments and applications including welding, working with fluids, humid or salty atmosphere



Solid Bar (a - mm)	Bar Opening (b - mm)	Jaw Depth (c - mm)	Clamping Force (kg)	Part No.
30 x 8	200	95	800	321200095
30 x 8	300	95	800	321300095
35 x 8	200	120	1200	321200120
35 x 8	300	120	1200	321300120
35 x 8	400	120	1200	321400120
35 x 8	600	120	1200	321600120
35 x 8	800	120	1200	321800120
35 x 8	1000	120	1200	3211000120
35 x 8	1200	120	1200	3211200120
40 x 10	400	140	1800	321400140
40 x 10	600	140	1800	321600140







# Industrial Clamps

## FX Folding Handle Clamps

- Aluminium Folding Handle
- Handle ensures ease of use, much quicker to tighten and accurate placement
- Unique, enclosed "spindle design" combined with ergonomic handle brings greater force with ease of use
- Lifetime Guarantee



Solid Bar(a- mm)	Bar Opening ( b - mm)	Jaw Depth ( c - mm)	Part No.
35 x 8	300	120	320300120
40 x 10	400	140	320400140
35 x 8	600	120	320600120
40 x 10	800	140	320600140
40 x 10	800	140	320800140



# Industrial Clamps

## EX Earth Clamps

- Unique design with earth lug and contact plate, for a safe and easy earth connection
- Special contact plate rated to 800amps
- Powerful clamping force with less effort
- High precision clamping
- Hardened steel bar brake
- Trapezoidal thread - totally sealed and permanently lubricated
- Suited to all environments and applications including welding, working with fluids, humid or salty atmosphere

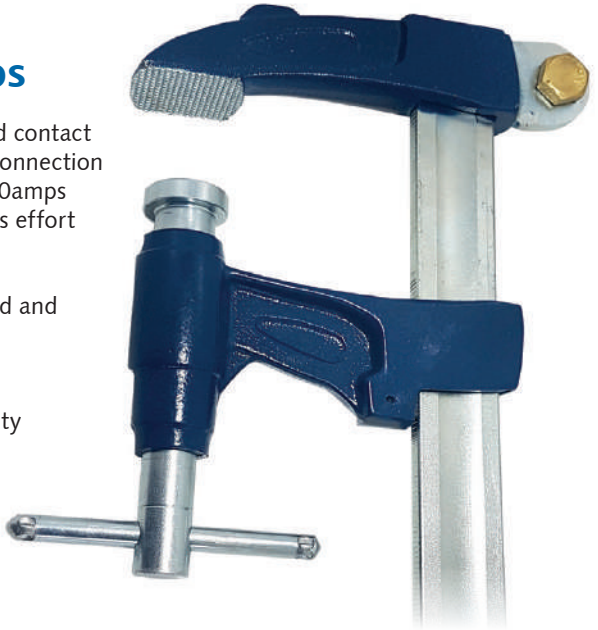
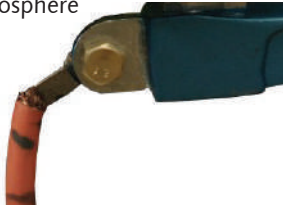

Solid Bar (a - mm)	Bar Opening (b - mm)	Jaw Depth (c - mm)	Clamping Force (kg)	Part No.
30 x 8	200	95	800	326200095
30 x 8	300	95	800	326300095
35 x 8	300	120	1200	326300120

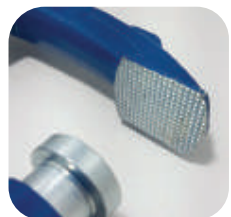



# Industrial Clamps

## LX Lever Clamps

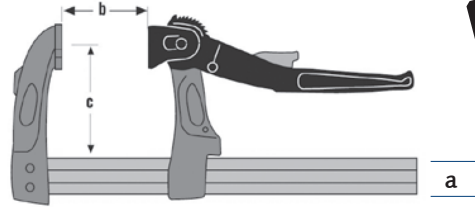

- Powerful clamping with less effort
- Quick locking, eccentric lever action with easy release trigger
- Suited to all environments and applications including welding, outdoor or gluing
- High precision clamping
- Hardened steel bar brake
- Made in Spain



Solid Bar (a - mm)	Bar Opening (b - mm)	Jaw Depth (c - mm)	Clamping Force (kg)	Part No.
35 x 8	400	120	1000	323400
35 x 8	600	120	1000	323600

## Magnetic Jaw Attachments

- Magnetic jaws for non-parallel clamping applications such as tube
- For use with the FX Xtreme clamps
- Swivel for difficult angles and applications

Description	Code
MAGNETIC JAW ATTACHMENTS	321001



# Industrial Clamps

## Xtreme Griplock Pliers

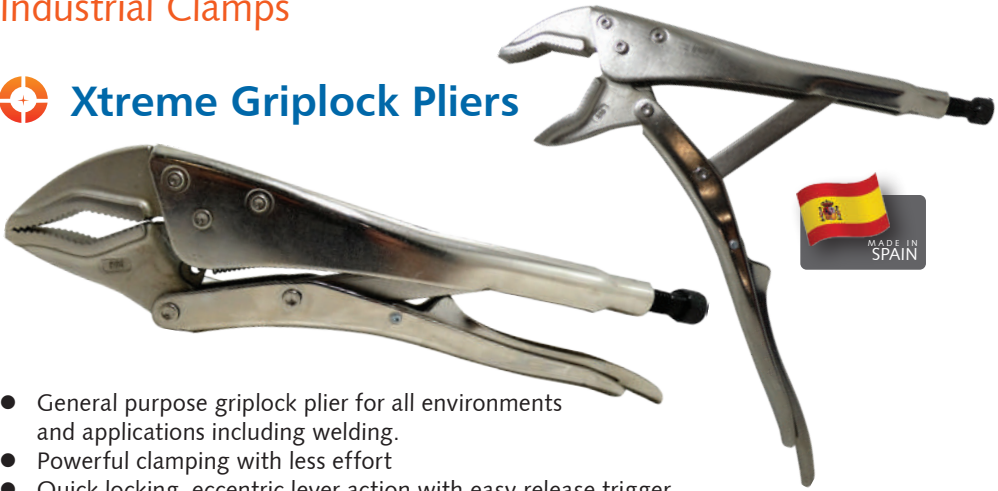

- General purpose griplock plier for all environments and applications including welding.
- Powerful clamping with less effort
- Quick locking, eccentric lever action with easy release trigger
- High precision clamping

Description	Code
XTREME GRIPLOCK PLIER - 250MM	331250
XTREME GRIPLOCK PLIER - 300MM	331300

## Xtreme Multi-Griplock Pliers



- Unique adjustable jaws with large range of applications
- Quick locking, with new ergonomic lever action with easy release trigger
- Easy-to-use finite adjustment with special designed wheel
- High precision and powerful clamping with less effort

Description	Code
XTREME MULTI-GRIPLOCK PLIERS - 250MM	332250

## Industrial Clamps

### Xtreme C-Clamp Griplock Pliers



- Large capacity jaws for easy clamping of profiles and sheet metal
- Quick locking, eccentric lever action with easy release trigger
- Ideal for welding and other tacking applications
- Available with swivel pads for easy clamping on uneven surfaces.

Description	Code
XTREME C-CLAMP GRIPLOCK PLIERS - 250MM	334250
XTREME C-CLAMP GRIPLOCK PLIERS W/SWIVEL PADS - 350MM	334350
XTREME C-CLAMP GRIPLOCK PLIERS W/SWIVEL PADS - 300MM	335300

### Xtreme Welding Griplock Pliers



- Ideal for welding and other tacking applications
- Quick locking, eccentric lever action with easy release trigger
- Suited to all environments and applications including welding, outdoor or gluing
- High precision clamping

Description	Code
XTREME WELDING GRIPLOCK PLIERS - 280MM	333280



# Notes

A series of horizontal dotted lines for taking notes.





[www.excision.com.au](http://www.excision.com.au)

Freecall: 1800 633 448  
Phone: +61 3 5551 4555  
Email: [info@excision.com.au](mailto:info@excision.com.au)