

***SCOUT***

F R A M E  
**MANUAL**

***NUKEPROOF***

**CONGRATULATIONS** ON YOUR PURCHASE  
AND WELCOME TO THE NUKEPROOF FAMILY!  
WE HOPE YOU ENJOY THE RIDE!

**#ENJOYRESPONSIBLY**

# CONTENTS PAGE

**03-04** // 275 + 290 FRAME INFORMATION

**05-06** // 275 GEOMETRY

**07-08** // 290 GEOMETRY

# 275 FRAME INFORMATION

**SCOUT**

## SCOUT 275 ALLOY

MATERIAL	HYDROFORMED 6061 TRIPLE-BUTTED ALUMINIUM
FORK TRAVEL	140MM
AXLE TO CROWN	529MM
FORK OFFSET	42MM
WHEELS SIZE	27.5"
MAX TYRE SIZE	2.8"
SIZING	S/M/L/XL
HEADTUBE	44-56MM TAPERED SEMI-INTEGRATED
HEADSET	ZS44-28.6 - T2 / ZS56/40 - BB
SEATPOST	31.6MM (INTERNAL ROUTING FOR DROPPER SEATPOST)
SEAT CLAMP	34.9MM
BB	THREADED 73MM BSA
REAR HUB	BOOST 148X12MM
REAR AXLE	SRAM MAXLE STEALTH M12X1.75 180MM
CHAIN GUIDE	ISC605
BRAKE MOUNT	160MM DIRECT POST
PROTECTION	KEVLAR CHAINSTAY PROTECTOR

# 290 FRAME INFORMATION

**SCOUT**

## SCOUT 290 ALLOY

MATERIAL	HYDROFORMED 6061 TRIPLE-BUTTED ALUMINIUM
FORK TRAVEL	130MM
AXLE TO CROWN	542MM
FORK OFFSET	51MM
WHEELS SIZE	29"
MAX TYRE SIZE	2.6"
SIZING	M/L/XL
HEADTUBE	44-56MM TAPERED SEMI-INTEGRATED
HEADSET	ZS44-28.6 - T2 / ZS56/40 - BB
SEATPOST	31.6MM (INTERNAL ROUTING FOR DROPPER SEATPOST)
SEAT CLAMP	34.9MM
BB	THREADED 73MM BSA
REAR HUB	BOOST 148X12MM
REAR AXLE	SRAM MAXLE STEALTH M12X1.75 180MM
CHAIN GUIDE	ISC605
BRAKE MOUNT	160MM DIRECT POST
PROTECTION	KEVLAR CHAINSTAY PROTECTOR

# 275 GEOMETRY

**SCOUT**

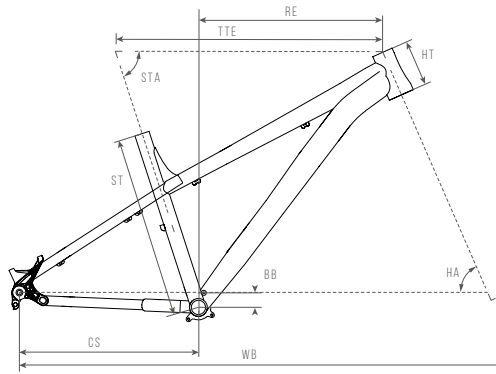

## SCOUT 275

FRAME SIZE	SMALL	MEDIUM	LARGE	X-LARGE
(ST) SEATTUBE LENGTH	380MM / 15"	420MM / 16.5"	460MM / 18"	510MM / 20"
(TTE) EFFECTIVE TOP TUBE LENGTH	586MM	611MM	637MM	662MM
(HT) HEADTUBE LENGTH	105MM	105MM	110MM	110MM
(HA) HEADTUBE ANGLE	65°	65°	65°	65°
(WB) WHEELBASE	1139MM	1164MM	1191MM	1216MM
(CS) CHAINSTAY LENGTH	435MM	435MM	435MM	435MM
(STE) EFFECTIVE SEATTUBE ANGLE	73°	73°	73°	73°
(BB) BOTTOM BRACKET DROP	-50MM	-50MM	-50MM	-50MM
BOTTOM BRACKET HEIGHT	310MM	310MM	310MM	310MM
(RE) REACH	400MM	425MM	450MM	475MM
STACK	608MM	608MM	613MM	613MM
FORK TRAVEL	140MM	140MM	140MM	140MM
FORK OFFSET	42MM	42MM	42MM	42MM
AXLE TO CROWN	529MM	529MM	529MM	529MM
SEAT POST DIAMETER	31.6MM	31.6MM	31.6MM	31.6MM
BOTTOM BRACKET TYPE	THREADED 73MM BSA	THREADED 73MM BSA	THREADED 73MM BSA	THREADED 73MM BSA
HEADSET TYPE	ZS 44MM/56MM SEMI INTEGRATED	ZS 44MM/56MM SEMI INTEGRATED	ZS 44MM/56MM SEMI INTEGRATED	ZS 44MM/56MM SEMI INTEGRATED

# 275 SAGGED GEOMETRY

**SCOUT**

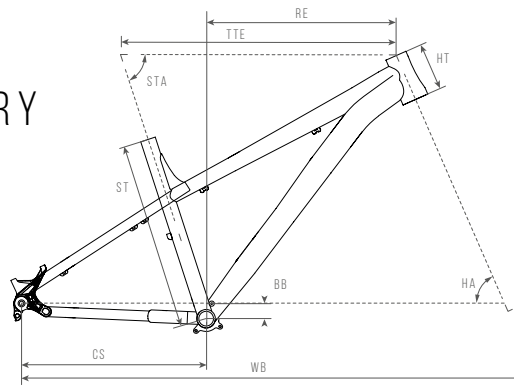

## SCOUT 275 - SAGGED

FRAME SIZE	SMALL	MEDIUM	LARGE	X-LARGE
(ST) SEATTUBE LENGTH	380MM / 15"	420MM / 16.5"	460MM / 18"	510MM / 20"
(TTE) EFFECTIVE TOP TUBE LENGTH	581MM	606MM	632MM	657MM
(HT) HEADTUBE LENGTH	105MM	105MM	110MM	110MM
(HA) HEADTUBE ANGLE	66.6°	66.6°	66.6°	66.6°
(WB) WHEELBASE	1125MM	1150MM	1177MM	1202MM
(CS) CHAINSTAY LENGTH	435MM	435MM	435MM	435MM
(STE) EFFECTIVE SEATTUBE ANGLE	74.6°	74.6°	74.6°	74.6°
(BB) BOTTOM BRACKET DROP	-62MM	-62MM	-62MM	-62MM
BOTTOM BRACKET HEIGHT	298MM	298MM	298MM	298MM
(RE) REACH	417MM	442MM	466.5MM	491MM
STACK	596MM	596MM	600MM	600MM
FORK TRAVEL	140MM (SAGGED)	140MM (SAGGED)	140MM (SAGGED)	140MM (SAGGED)
FORK OFFSET	42MM	42MM	42MM	42MM
AXLE TO CROWN	494MM	529MM	529MM	529MM
SEAT POST DIAMETER	31.6MM	31.6MM	31.6MM	31.6MM
BOTTOM BRACKET TYPE	THREADED 73MM BSA	THREADED 73MM BSA	THREADED 73MM BSA	THREADED 73MM BSA
HEADSET TYPE	ZS 44MM/56MM SEMI INTEGRATED	ZS 44MM/56MM SEMI INTEGRATED	ZS 44MM/56MM SEMI INTEGRATED	ZS 44MM/56MM SEMI INTEGRATED

# 290 GEOMETRY

**SCOUT**

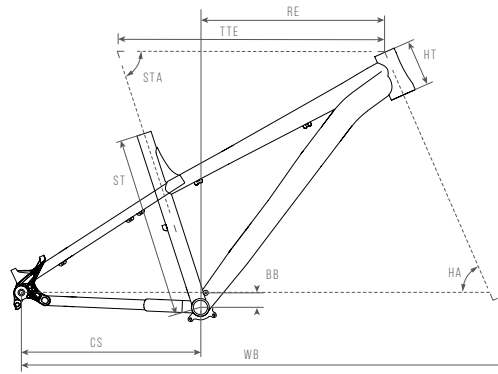

## SCOUT 290

FRAME SIZE	MEDIUM	LARGE	X-LARGE
(ST) SEATTUBE LENGTH	420MM / 16.5"	460MM / 18"	510MM / 20"
(TTE) EFFECTIVE TOP TUBE LENGTH	620MM	646MM	671MM
(HT) HEADTUBE LENGTH	105MM	110MM	110MM
(HA) HEADTUBE ANGLE	65°	65°	65°
(WB) WHEELBASE	1175MM	1202MM	1227MM
(CS) CHAINSTAY LENGTH	440MM	440MM	440MM
(STE) EFFECTIVE SEATTUBE ANGLE	73°	73°	73°
(BB) BOTTOM BRACKET DROP	-70MM	-70MM	-70MM
BOTTOM BRACKET HEIGHT	300MM	300MM	300MM
(RE) REACH	425MM	450MM	475MM
STACK	639CM	643CM	643CM
FORK TRAVEL	130MM	130MM	130MM
FORK OFFSET	51MM	51MM	51MM
AXLE TO CROWN	542MM	542MM	542MM
SEAT POST DIAMETER	31.6MM	31.6MM	31.6MM
BOTTOM BRACKET TYPE	THREADED 73MM BSA	THREADED 73MM BSA	THREADED 73MM BSA
HEADSET TYPE	ZS 44MM/56MM SEMI INTEGRATED	ZS 44MM/56MM SEMI INTEGRATED	ZS 44MM/56MM SEMI INTEGRATED



# 290 SAGGED GEOMETRY

**SCOUT**

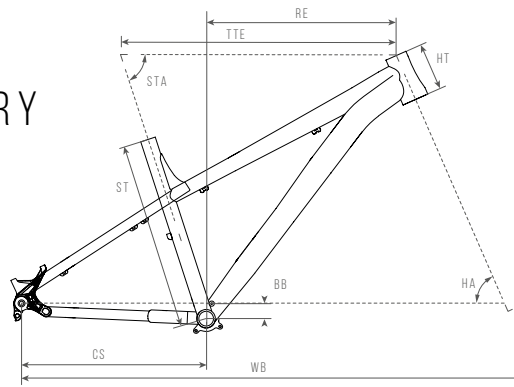

## SCOUT 290 - SAGGED

FRAME SIZE	MEDIUM	LARGE	X-LARGE
(ST) SEATTUBE LENGTH	420MM / 16.5"	460MM / 18"	510MM / 20"
(TTE) EFFECTIVE TOP TUBE LENGTH	615MM	641MM	666MM
(HT) HEADTUBE LENGTH	105MM	110MM	110MM
(HA) HEADTUBE ANGLE	66.5°	66.5°	66.5°
(WB) WHEELBASE	1162MM	1189MM	1214MM
(CS) CHAINSTAY LENGTH	440MM	440MM	440MM
(STE) EFFECTIVE SEATTUBE ANGLE	74.5°	74.5°	74.5°
(BB) BOTTOM BRACKET DROP	-80MM	-80MM	-80MM
BOTTOM BRACKET HEIGHT	290MM	290MM	290MM
(RE) REACH	441MM	466MM	490.5MM
STACK	628CM	632CM	631CM
FORK TRAVEL	130MM SAGGED	130MM SAGGED	130MM SAGGED
FORK OFFSET	51MM	51MM	51MM
AXLE TO CROWN	509.5MM	509.5MM	509.5MM
SEAT POST DIAMETER	31.6MM	31.6MM	31.6MM
BOTTOM BRACKET TYPE	THREADED 73MM BSA	THREADED 73MM BSA	THREADED 73MM BSA
HEADSET TYPE	ZS 44MM/56MM SEMI INTEGRATED	ZS 44MM/56MM SEMI INTEGRATED	ZS 44MM/56MM SEMI INTEGRATED

** NUKEPROOF**

FOR ANY MORE INFORMATION PLEASE VISIT [WWW.NUKEPROOF.COM](http://WWW.NUKEPROOF.COM)

**#REDEFINEYOURLIMIT**