

MAKE IT MODULAR

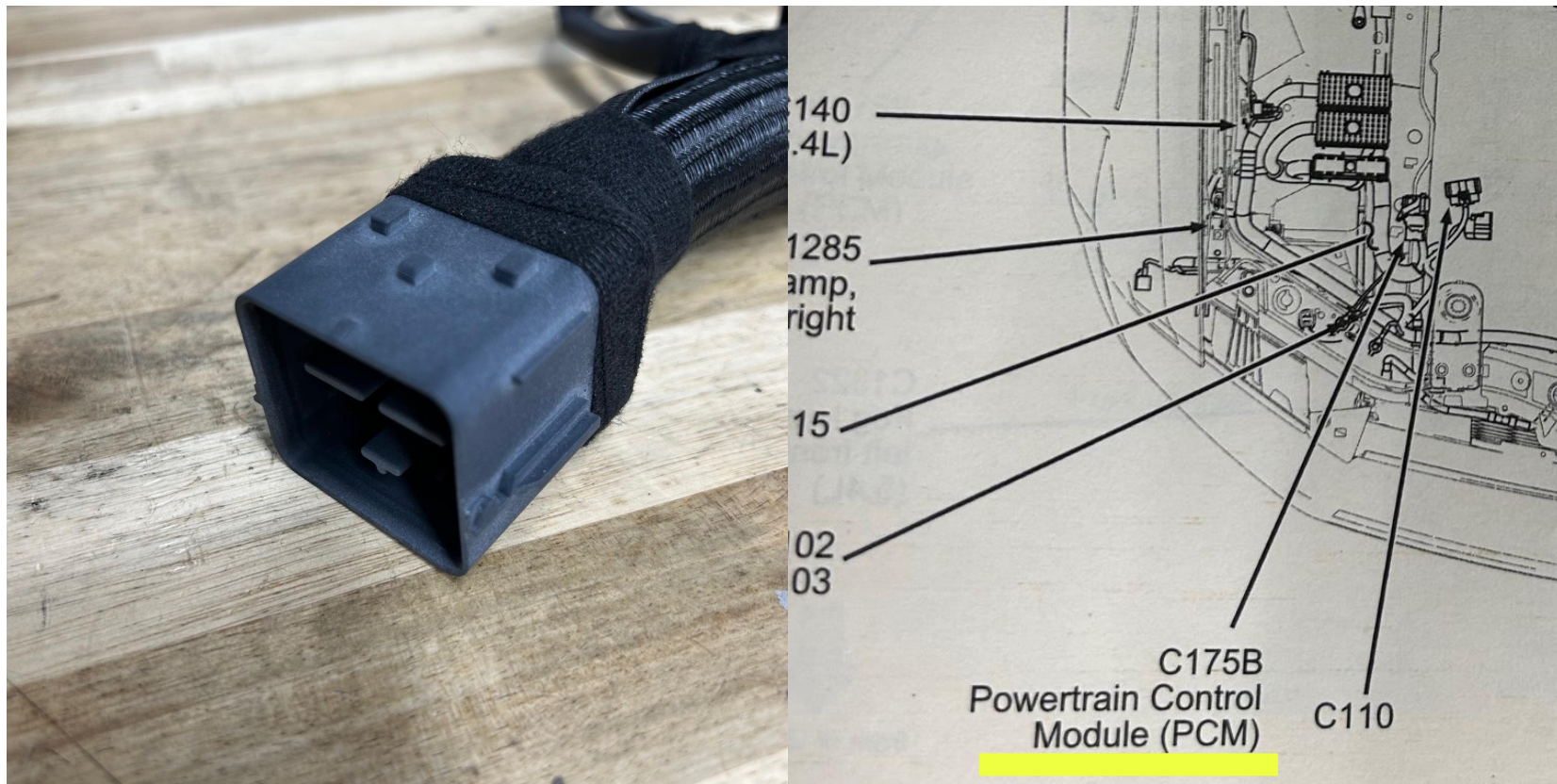

2005-2009 MUSTANG COYOTE SWAP PLUG AND PLAY HARNESS

THIS MALE C175B CONNECTOR HOOKS UP TO THE BODY SIDE C175 4.6 CONNECTOR



THIS MALE C110 CONNECTOR HOOKS UP TO THE BODY SIDE C110 4.6 CONNECTOR, 2005 CARS WILL HAVE TO SPLICE THIS WIRE INTO THE BODY SIDE C110

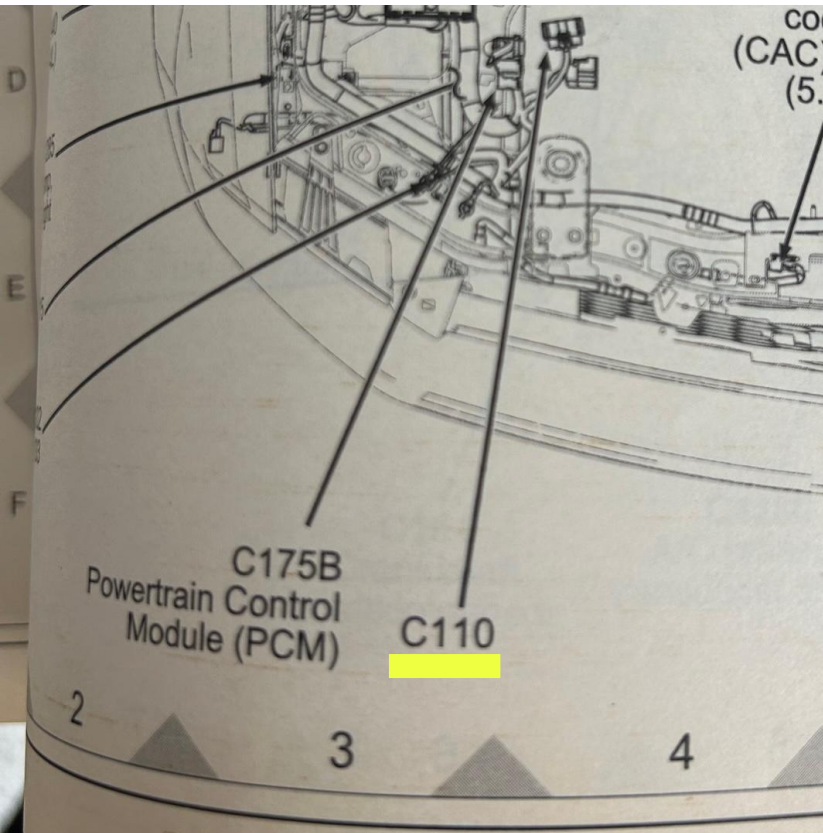
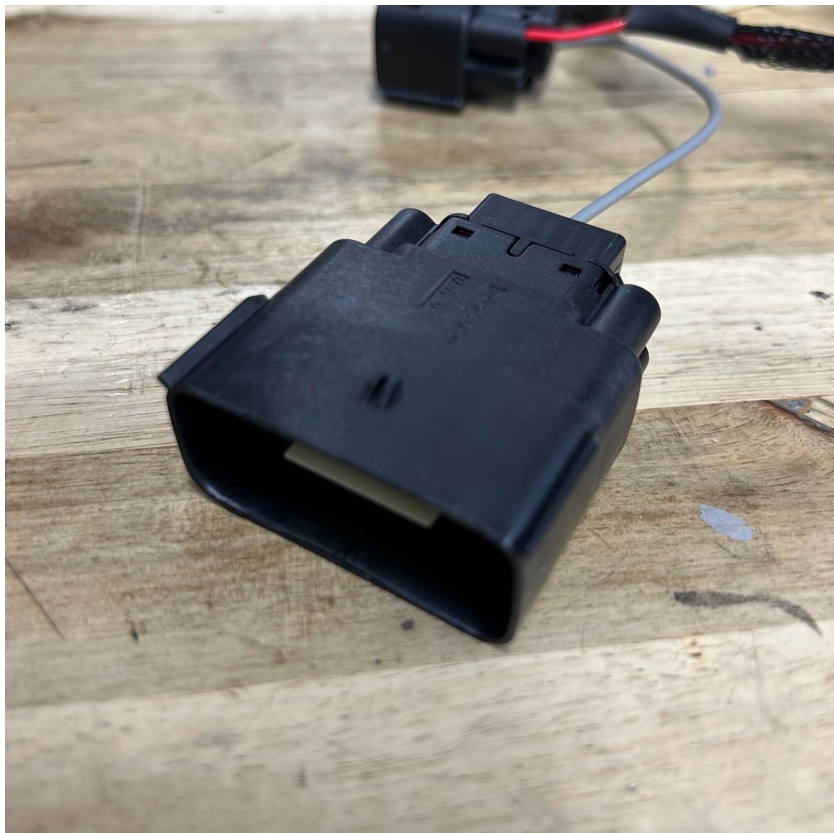

THIS IS THE LOW PRESSURE A/C SWITCH AND CONNECTS TO THE LOW SIDE AC SWITCH ON THE DRIVER SIDE FIREWALL

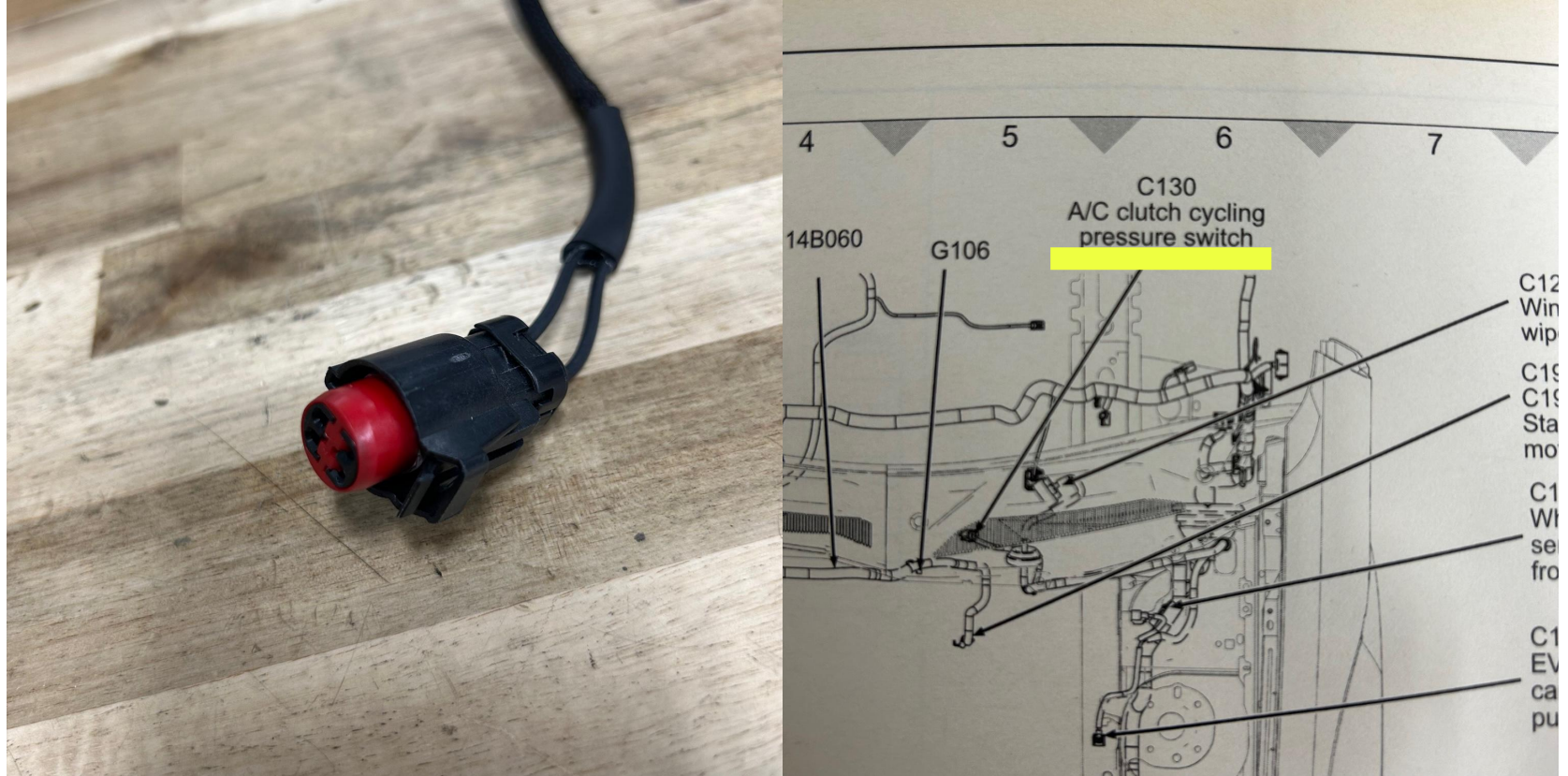

THIS C1035B CONNECTOR, BOLTS INTO THE THIRD POSITION OF THE FUSE BOX

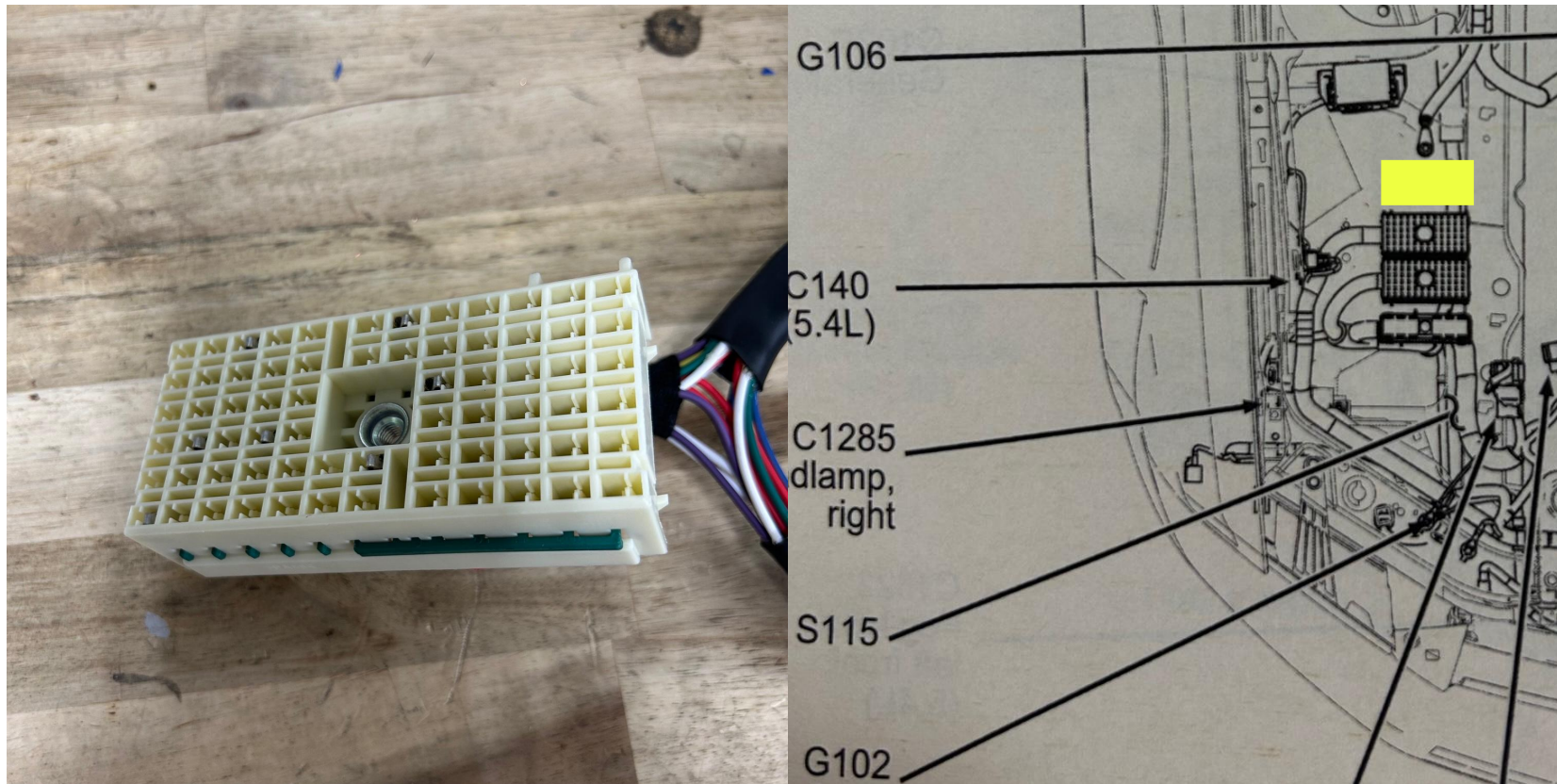

THIS MALE C110 CONNECTOR HOOKS UP TO THE C110 TRANSMISSION HARNESS INLINE CONNECTOR

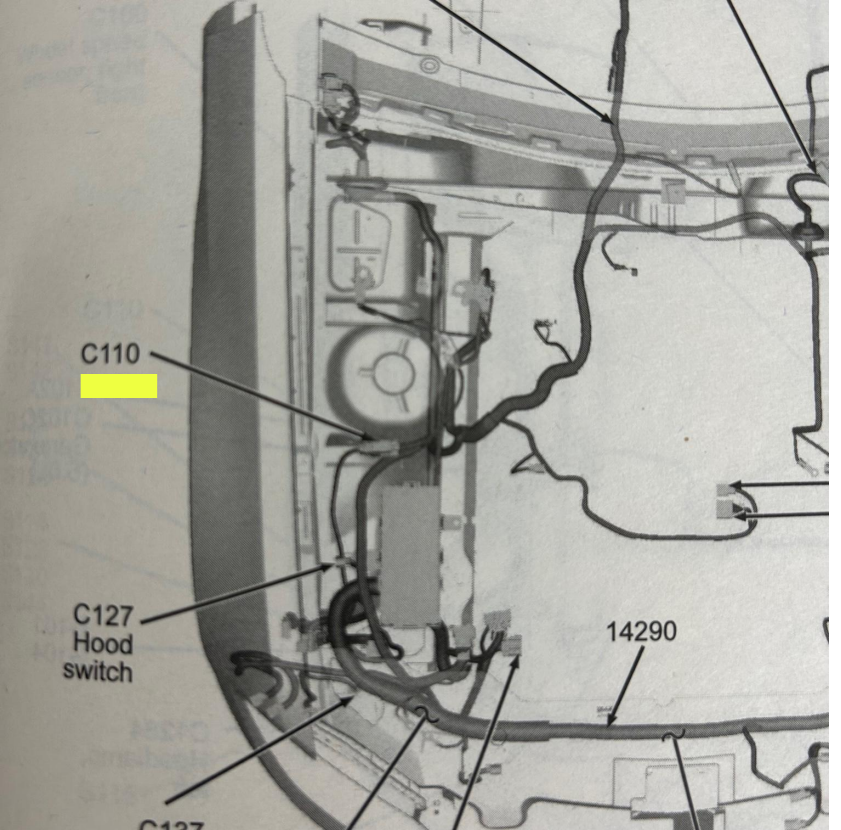

THIS FEMALE C175B CONNECTOR PLUGS INTO THE COYOTE ECU

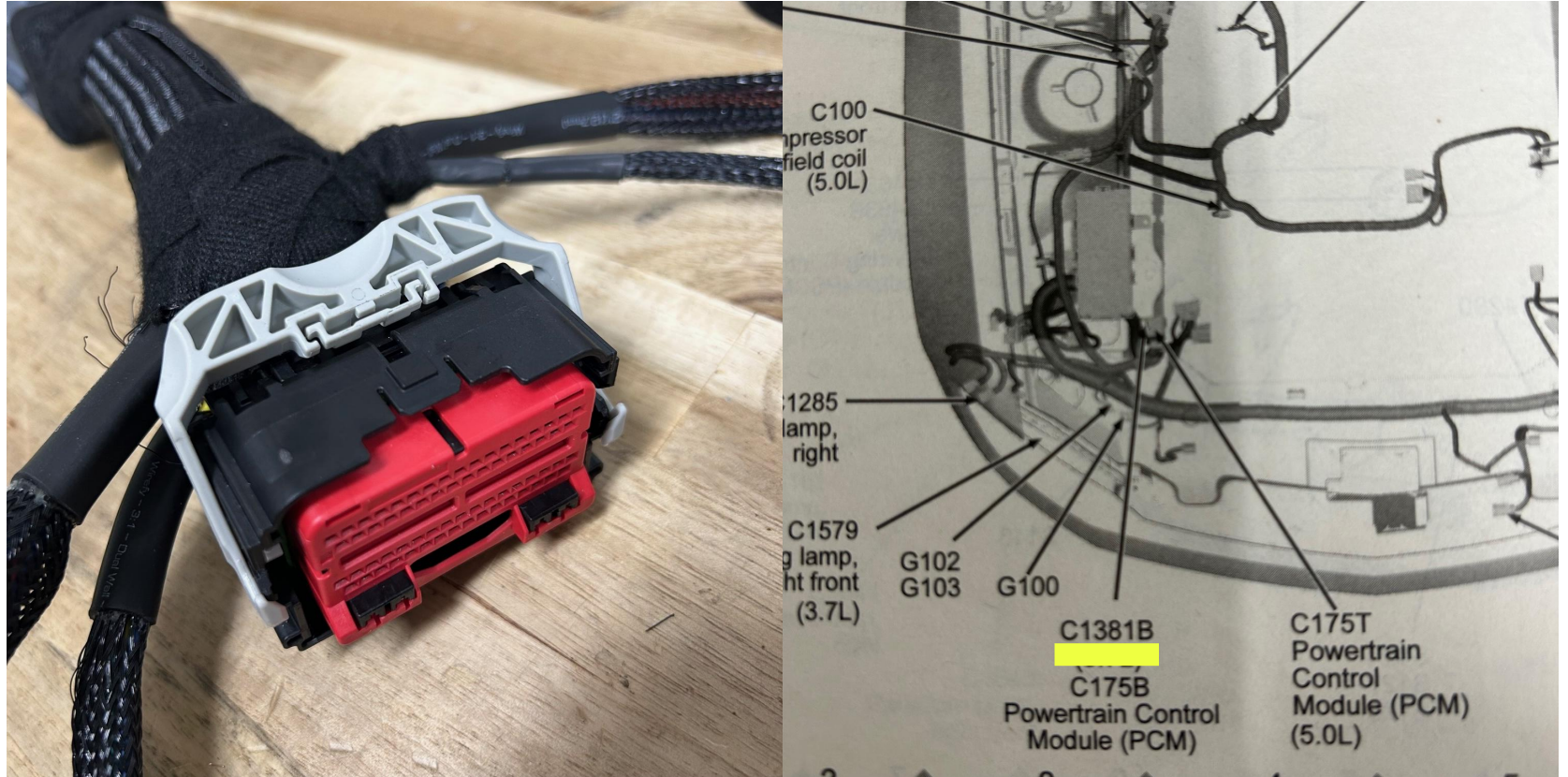

THIS IS THE MASS AIR FLOW CONNECTOR, CONNECTS TO THE MAF SENSOR IN THE INTAKE TUBE

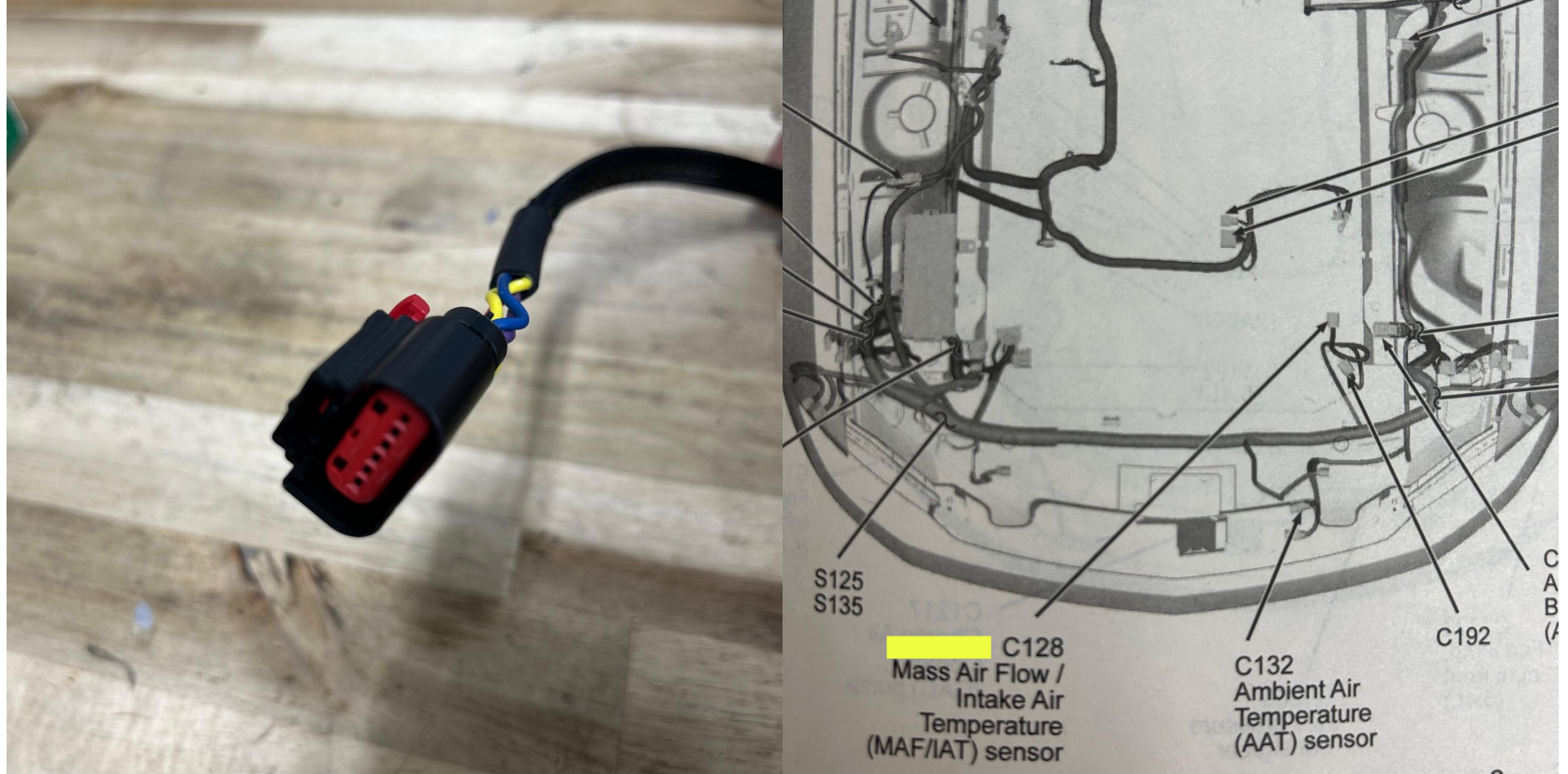

THIS FEMALE C146 ENGINE INLINE CONNECTOR PLUGS INTO THE ENGINE HARNESS INLINE CONNECTOR

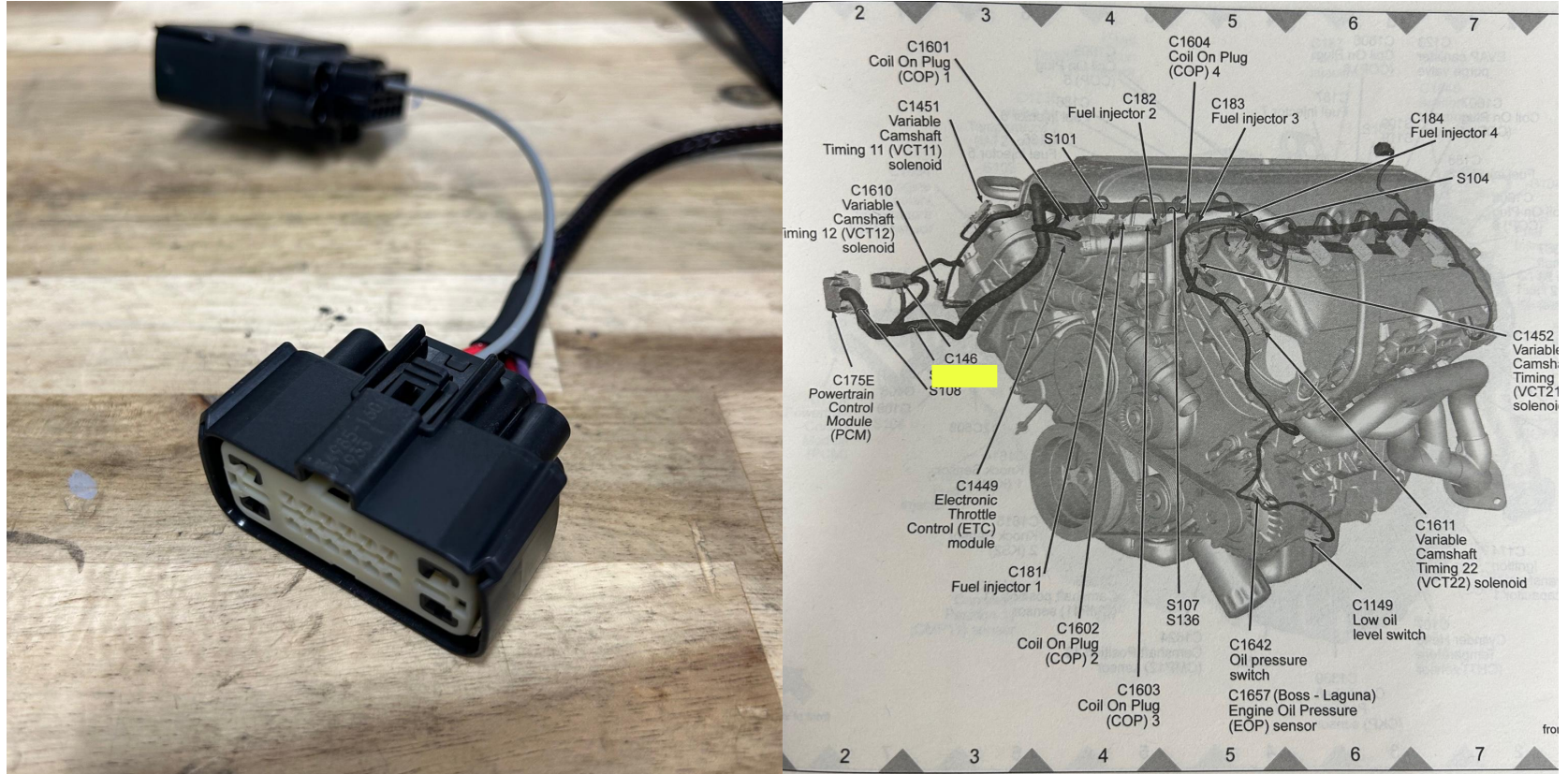

THIS IS THE ACCELERATOR PEDAL CONNECTOR THAT CONNECTS UNDER THE DASH, SUGGEST TO ROUTE THROUGH DRIVER SIDE GROMMET

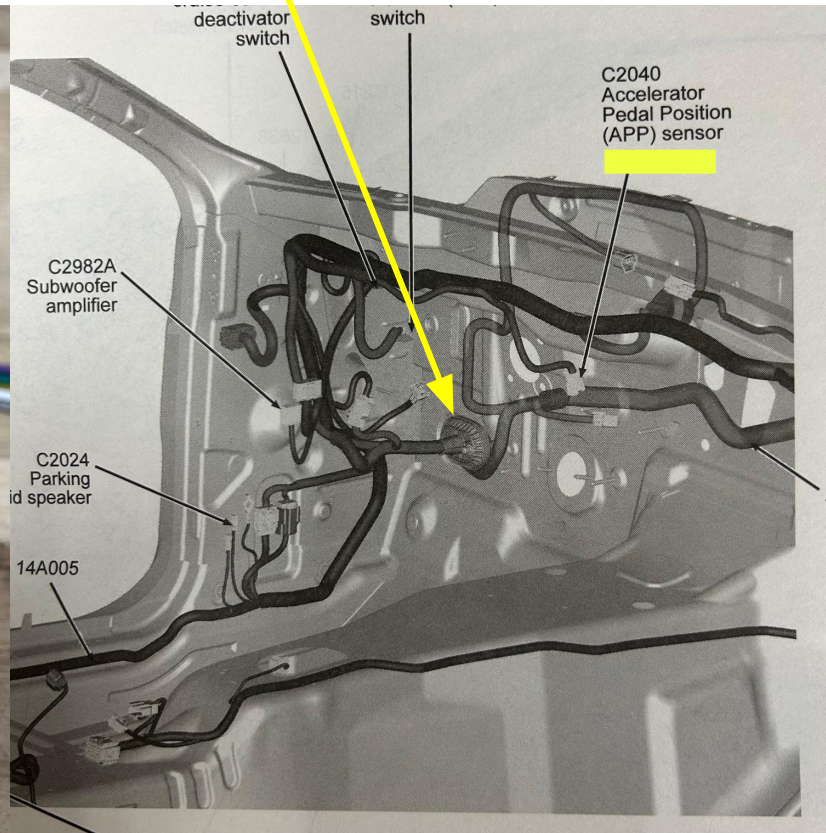

THIS IS THE HIGH PRESSURE/TRANSDUCER CONNECTOR, PLUGS INTO THE HI SIDE AC SWITCH LOCATED ON THE DRIVER SIDE NEAR THE ABS/AIR BOX, BELOW THE MAF

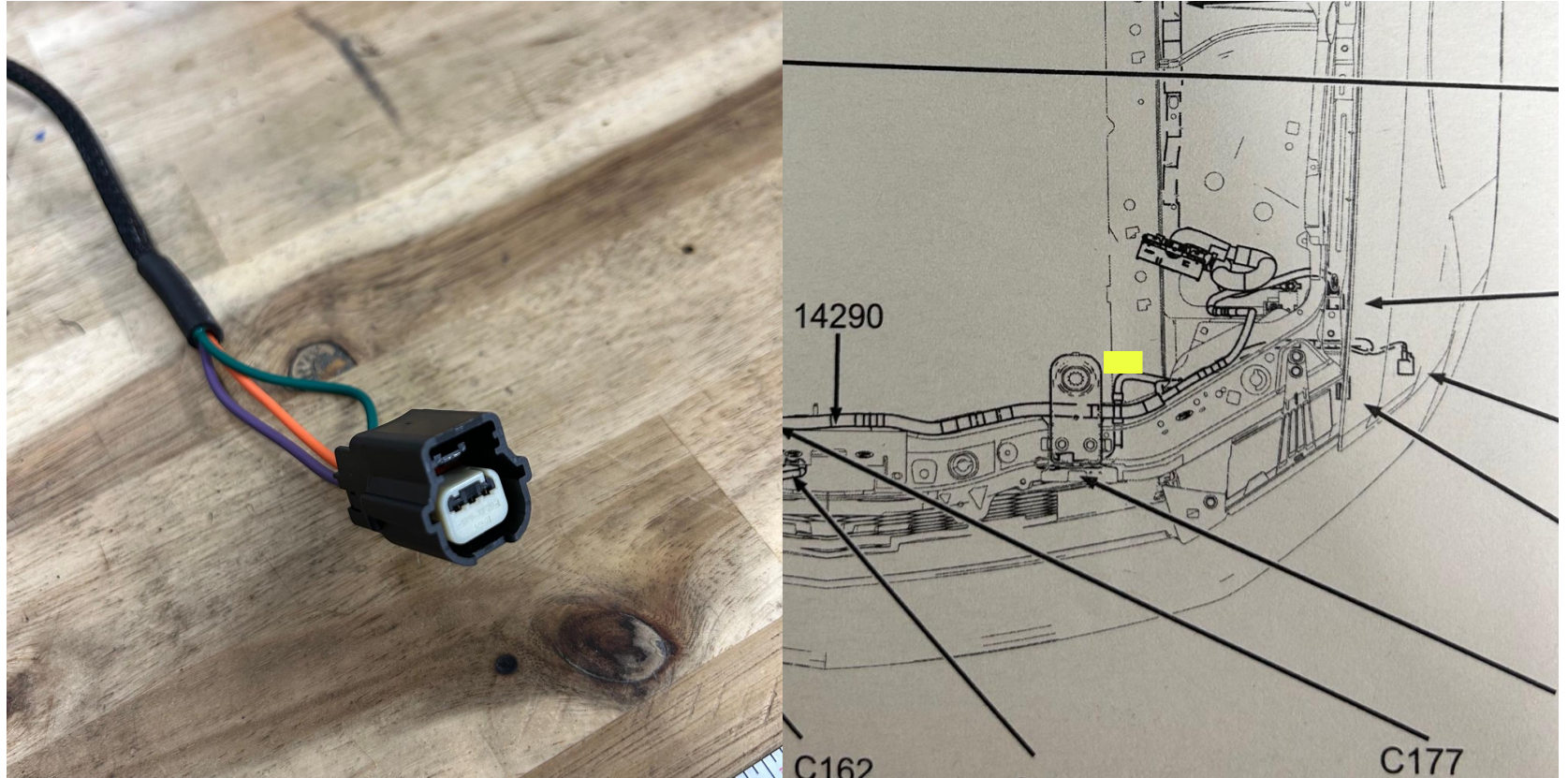

FOR 2005 VEHICLES, FOLLOW STEP 1) FOR YOUR OIL PRSSURE GAGE WIRE.
FOR 2005-2006 VEHICLES THAT OPTED TO HAVE CRUISE FUNCTION, FOLLOW STEP 2)

1) CONNECT LABELED WIRE PIN 5 FROM C146 ENGINE INLINE TO YOUR C110 BODY INLINE TO PIN 11

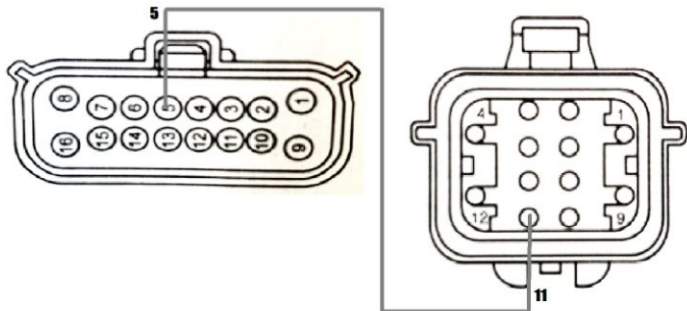

2) CONNECT PIN 6 LABELED WIRE FROM C110 TRANS CONNECTOR AS SHOWN BELOW

