



AEA ELEMENT MAX AIR RIFLE USER'S MANUAL

WWW.AEAAIRGUN.COM

WARNING

READ ALL INSTRUCTIONS AND WARNINGS BEFORE USING AEA PRODUCTS

This air rifle is not a toy and carelessness use may result in serious injury or accidental death.

This airgun is recommended for adult use or under adult supervision.

Never attempt to disassemble this rifle without manufacturer authority.

Never fire the rifle when it is out of air or when air cylinder is removed!

Use lead pellets only, The use of any projectile other than a lead pellet is unauthorized and will void the manufacturers warranty.

AEA Airguns are designed for Use with dry-filtered, compressed air to fill the air cylinder.

NEVER use other gases such as oxygen, acetylene, hydrogen, etc.

Never fill this air rifle air cylinder above 310 BAR /4500 PSI (working pressure) unless stated for the specific model.

The resulting damage caused by overcharging the air cylinder is not covered by the manufacturers warranty.

ALWAYS wear eye and ear protection when using an airgun.

Always point the air rifle in a safe direction and be aware of the backstop.

Never point an air rifle at anything you do not intend to shoot.

Always make sure that each pellet you use is in the proper caliber for the air gun and never re-use pellets.

Never leave the air gun loaded if it is not going to be used.

Keep your fingers away from the trigger and do not load the rifle until you are ready to fire.

Anytime you transport an airgun, make sure the safety is on and the gun is unloaded.

Store the airgun (unloaded) and ammunition in separate, safe places, out of reach of children.

Users should follow all local laws regarding air gun ownership and use..

We recommended that you have the air cylinder visually inspected every 3 years.

FAILURE TO OBSERVE THE ABOVE WARNINGS CAN RESULT IN DAMAGE TO YOUR AIR RIFLE, ACCIDENTAL DEATH OR SERIOUS INJURY. PRACTICE GUN

SAFETY AND RESPONSIBILITY

AEA ELEMENT MAX AIR RIFLE

READ ALL INSTRUCTIONS AND WARNINGS BEFORE USING THIS AIRGUN



SPECIFICATION

CALIBER	.45 CAL
	.50 CAL
	.51 CAL
	.58 CAL
Weight	5.2 LBS
Barrel Length	22 Inches
Overall Length	37 Inches
Folding Length	27 Inches
Cocking System	REVERSIBLE SWING HAMMER
SINGLE SHOOT LOADING WITH NO MAG	
Air Filling Pressure	4500 PSI
Air Tube Capacity	330 CC (FRONT TUBE)
* AIR TUBE CAPACITY MAX UPGRADE UP TO 1030 CC (More info please consult AEA dealers)	
Muzzle Energy	.45 CAL UP TO 400 FPE
	.50 CAL UP TO 450 FPE
	.510 CAL UP TO 480 FPE
	.58 CAL UP TO 600 FPE
Optics	Picatinny Rail Scope Mount

FAILURE TO OBSERVE THE WARNINGS & CAUTIONS CAN RESULT IN DAMAGE TO YOUR AIR RIFLE, ACCIDENTAL DEATH OR SERIOUS INJURY. THE SAFE USE AND STORAGE IS THE OWNER / USER'S RESPONSIBILITY.

AEA ELEMENT MAX AIR RIFLE DIAGRAM

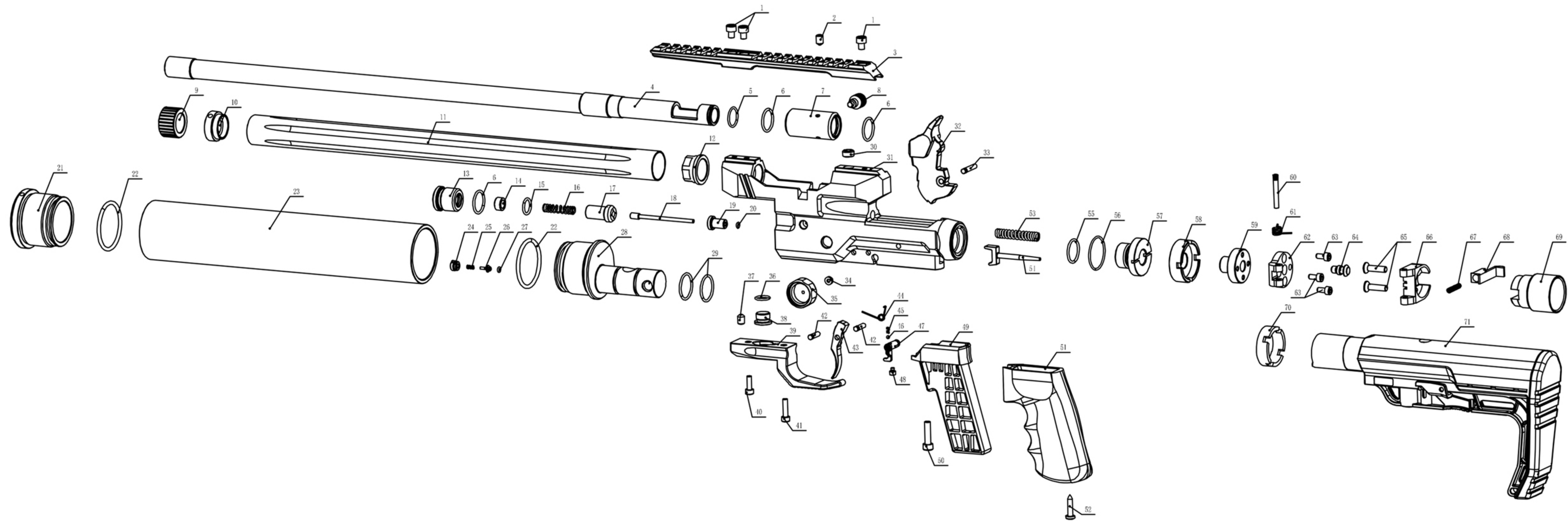

REVISED 01/2023



www.aaairgun.com

aaairgun@gmail.com

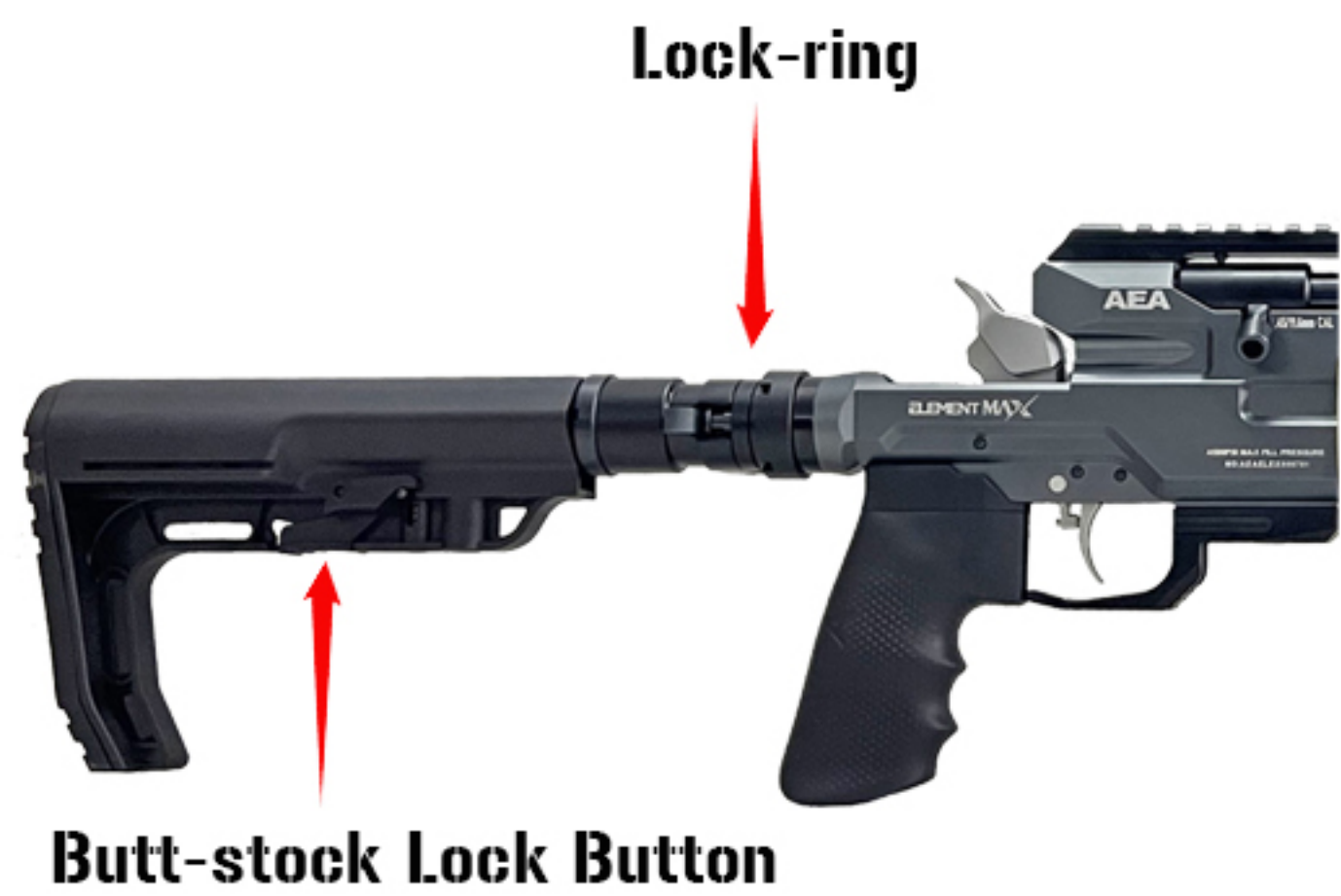

Butt-Stock Adjusting

Rotate the butt-stock in the comfortable position so that the butt-stock matches your shooting position. Then rotate the lock-ring tightly in order to lock butt-stock position. Push the butt-stock tube locking button and matches your comfortable shooting position.

Air Filling

1. Insert 8mm air fill probe into your air filling devices (such as high pressure air compressor, scuba air tanks, hand pump or recharging station) hose connector.
Notice: Before filling, secure that devices hose and the fill probe connecting tightly.

2. Insert the 8mm fill probe into the air filling hole on the chassis.

3. Close the bleed screw on your recharging devices, open the recharging devices valve very slowly. When recharging you must watch the gun's air tube gauge and the air filling devices air gauge carefully. Never exceed 310 bar / 4500 psi (unless the model allows it). When the air fill is complete, close the recharging devices valves. To disconnect the cylinder from the air filling devices, open the bleed screw. This allows high pressure air inside the refill clamp to exhaust, making it possible to pull out the 8mm fill prob from air filling hole.

WARNING

AEA Airguns are designed for Use with dry-filtered, compressed air only. Never use other gases such as oxygen, acetylene, hydrogen, etc. Never fill the air cylinder above 310 BAR /4500 psi unless model specified. The resulting damage caused by overcharging the air cylinder or air tank is not covered by the manufacturer's warranty.



BULLET LOADING

WARNING

Lead slugs shoot only. The use of any projectile other than a lead slug is unauthorized and will void the manufacturer's warranty.

Always make sure that each slug you use is the proper caliber for the airgun and never re-use slugs. BEFORE LOADING YOUR AIRGUN. MAKE SURE THE SAFETY IS IN THE ON SAFE POSITION AND THE MUZZLE IS POINTED IN A SAFE DIRECTION ALL THE TIME

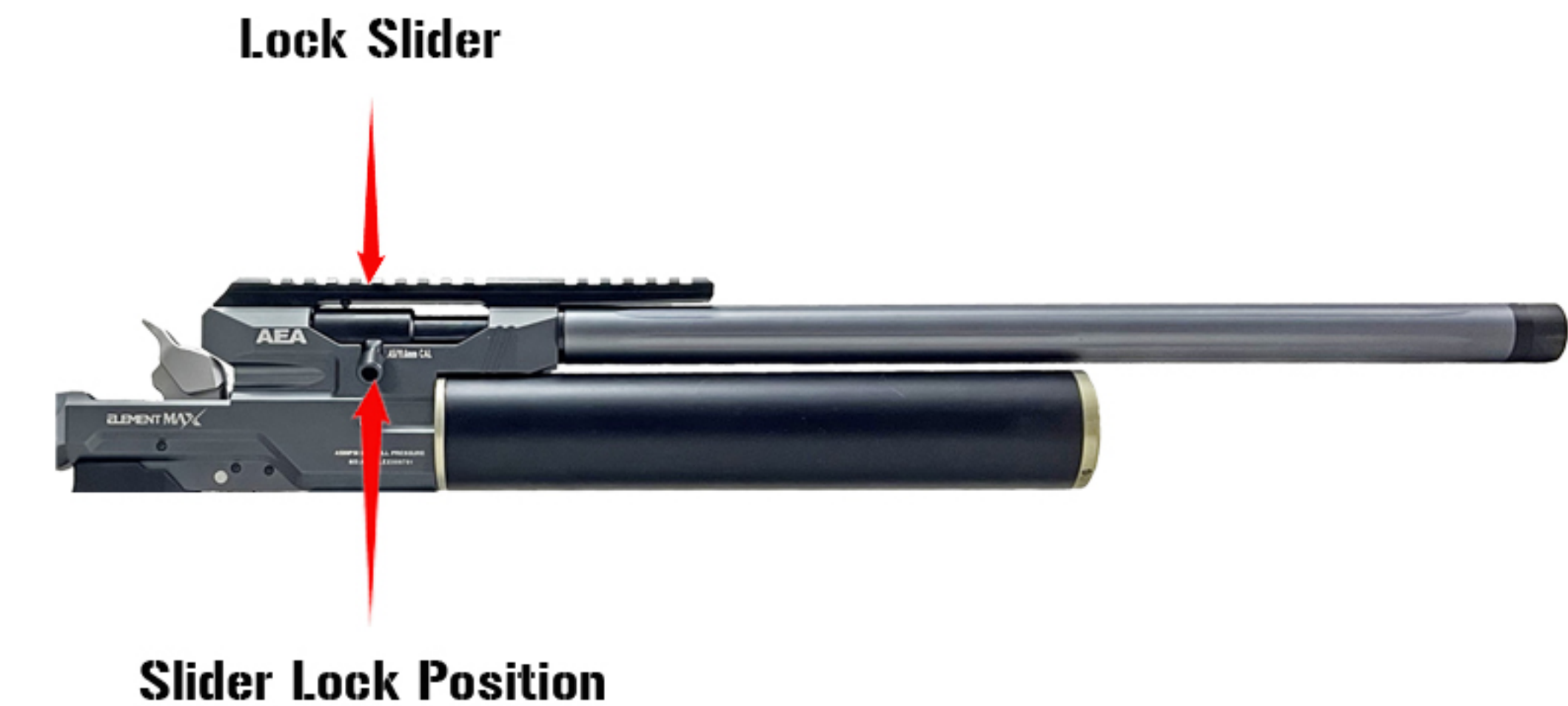

To load your air rifle, hold the lock slider handle, move it up and push it forward to the muzzle direction. Load the proper caliber slug for your air rifle. Move the lock slider to the locking position.

WARNING

BEFORE SHOOT YOUR AIR RIFLE MAKE SURE THE LOCK SLIDER IS IN THE LOCKING POSITION

Cocking, Discharging, and Firing

WARNING

Before COCKING the airgun make sure the safety is in the On Safe position and the muzzle is pointed in a safe direction all the time.



Push the safety button down to the safety position

Manually move the safety to the on safe position by switching safety button on the chassis.

Hammer



To cock the air rifle, hold the hammer tightly and move until the hammer is held in the cocked position.

WARNING

HOLD THE HAMMER TIGHTLY DO NOT RELEASE THE HAMMER WHEN MOVING THE HAMMER TO THE COCKING POSITION

To fire, take your target, aim, switch the safety to the fire position and squeeze the trigger until the air rifle discharges.

Hammer



HAMMER DE COCK

To de cock the hammer, hold the hammer and squeeze the trigger slowly to decock the hammer spring while holding the hammer.

WARNING

Do not move the safety to the Fire position unless the air gun is pointed in a safe direction. Practice safe and responsible gun handling practices.

After de cocking the hammer, always to dry fire the air rifle in a safe direction to ensure the breech is clear.

OPERATIONAL NOTICES

Modification, Removing or disassembling the safety mechanism

Modification, disassembling or removing any of the safety parts can disable the rifle and will void the warranty and will create a hazardous condition.

MODIFICATIONS TO THE VALVE

The valve in the air rifle is not a user-maintainable item. Any attempt to remove or modify the valve in any way will void the warranty and may create a hazardous condition. Filling the air tank with a gas other than dry compressed air is not recommended and will void the warranty.

CLEANING THE BARREL

An airgun barrel needs standard maintenance. If you do clean the barrel, use a good quality bore brush of the correct size, and use a non-jointed cleaning rod if possible. Do not use cleaning solvents and agents formulated for firearms because they can damage the seals and O-rings, use silicon cleaning lubricants and cleaning products.

WARNING

This rifle should only be disassembled by factory-authorized technician and a factory-authorized repair station, or you will void manufacturer warranty automatically including any modification or tuning as well.

MAINTENANCE OF THE AIR CYLINDER

AEA Airguns' air cylinder is made of 7075 aluminium alloy. The air cylinders are designed for Use with dry-filtered, compressed air to fill the air cylinder. Never use other gases such as oxygen, acetylene, hydrogen, etc. Never fill the air cylinder above 310 BAR /4500 psi. The resulting damage caused by overcharging the air cylinder is not covered by the manufacturer's warranty.

SHOOTING SAFETY

Never point the muzzle of the rifle at anything you do not intend to shoot. Practice gun safety and responsible gun ownership. Always wear safety glasses when shooting or operating an air rifle, safety first! Avoid shooting targets that will make the pellet ricochet.

WARRANTY INFORMATION

All AEA Airguns carry ONE YEAR Manufacturer Warranty against faulty workmanship and defective materials. The Manufacturer Warranty will start automatically after you purchased an AEA product from the dealer. Any AEA airguns covered by this warranty will be repaired or replaced at the discretion of AEA Precision Airguns Inc, should a defect in material or workmanship be found, Contact your dealer first. If the rifle is determined to have a defect within the warranty period, contact the warranty center or authorized repair facility to arrange service. The warranty guarantee does not cover any damage caused by tampering with the air rifle or abuse. Normal wear parts such as O-rings and plastic magazines are not covered as well. Repairs may only be made by the Manufacturer Warranty Center or authorized repair facility. This warranty becomes invalid for any gun that is disassembled or modified in any way not specifically authorized by AEA Precision Airguns Manufacturer. This warranty also becomes invalid for any gun that has been damaged by abuse or improper handling.

A ONE YEAR manufacturer's warranty applies in those instances for all AEA airguns.

Official Website: www.aeaairgun.com

Email: aeaairgun@gmail.com

**Photographs, drawings, descriptions, and other information are purely indicative.
AEA Precision Airguns reserves the right to change, modify, or discontinue products or features at any time.**

Various AEA Airguns Bring You Completely Different Experiences



AEA
PRECISION AIRGUNS

AEA PRECISION AIRGUNS INC.

www.aeaairgun.com

aeaairgun@gmail.com