

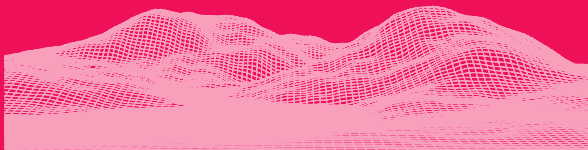

# SONIC MEGA 8K V2



**Dear User,**

Thank you for joining us. Please read the Sonic Mega 8K V2 manual thoroughly and follow the instructions step by step to get the best printing experience.

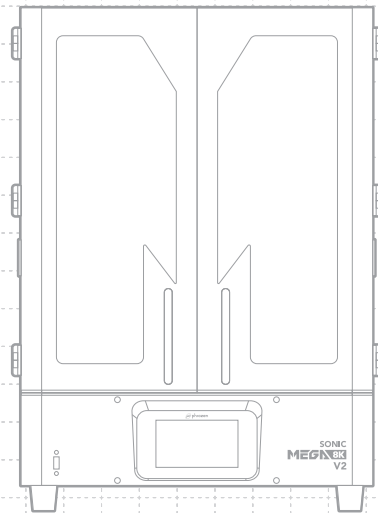



Please scan the QR code for  
Sonic Mega 8K V2 user manual  
in other languages.

01 Key Notes Before Start	03
02 Introduction	05
03 Prepare Your 3D Printer	07
· LCD Test	07
· Z-Offset Setting	07
· Z-Axis Calibration	08
04 Prepare Your Print File	09
05 File Import & Ethernet	09
06 First Test Print	11

# 01 Key Notes Before Start

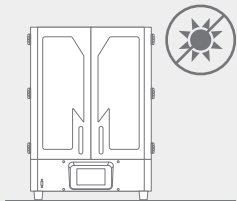

## Stable Printing Environment

Store your 3D printer in a dry and well-ventilated environment. Place it on a flat surface and avoid direct sunlight exposure.

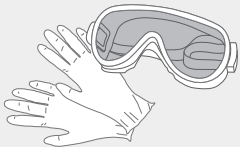

## Protective Measures

When handling resins or prints, please wear Personal Protective Equipment such as gloves, masks, protective goggles, and long-sleeved clothes.

## Maintenance

### Clean the Z-Axis

First, wipe the Ball Screw with Lint Free Wipes. Then, apply some lithium-based lubricant so the ball screw spins smoothly.

### Clean the 3D Printer

Use 95% alcohol and Lint Free Wipes to carefully clean the printer, resin vat, and the building plate.

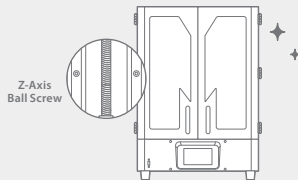

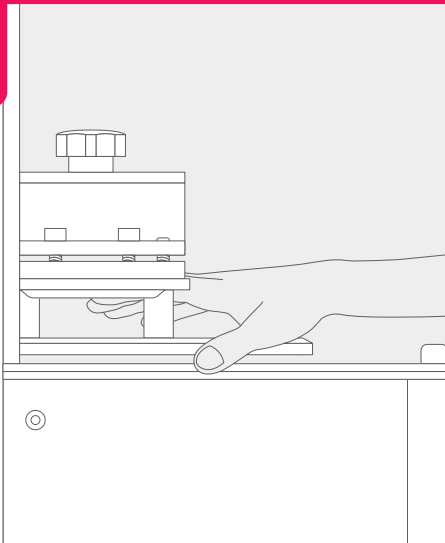

## Pre-Calibrated Z-Axis design

The Sonic Mega 8K V2 comes with a pre-calibrated building plate. You can start printing straight out of the box.

If the building plate, Z-rod, LCD panel, or screen protector was previously replaced, please perform "Z-Axis Calibration".

-----  
If you have any technical questions, please scan the QR code to contact our support team.



## 02 Introduction

### Printer Parts

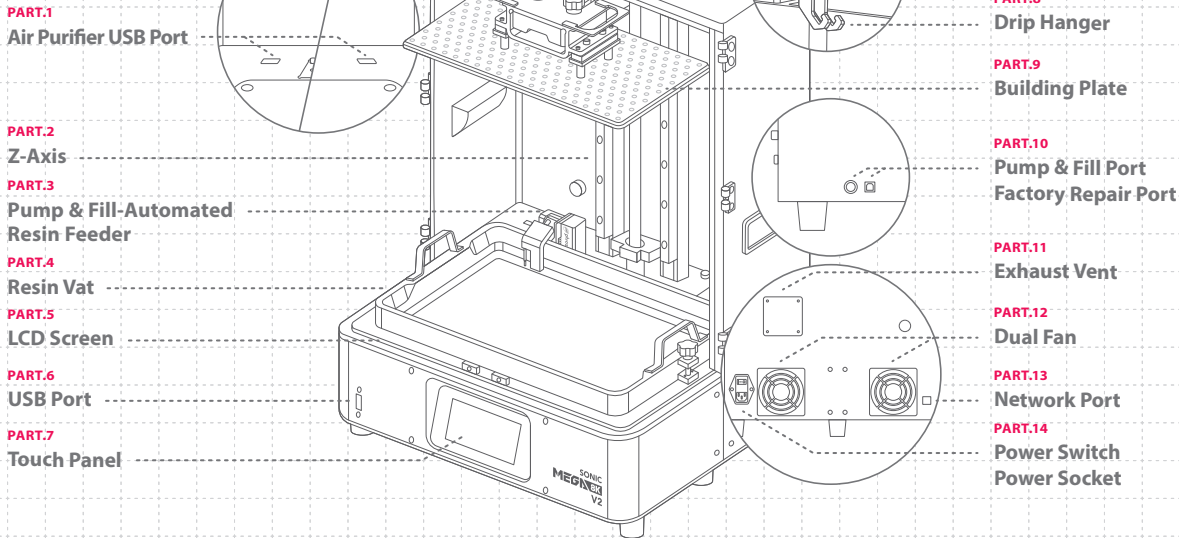

## The Toolbox



Warranty Card



Gloves



AC Cable Standards  
1.5 m EU/US



Plastic Funnel



Metal Scraper



Plastic Scraper



Allen Wrench Set



USB Stick



Handles



USB Air Purifier



Magnetic Fan Cover

## Operation

System	Phrozen OS
Operation	5 inch Touch Panel
Slicer Software	CHITUBOX V1.9.6 and above (Or others)
Connectivity	USB   Ethernet

## Printing Specifications

Technology	Resin 3D Printer - LCD Type
Light Source	405 nm ParaLED® Matrix 3.0
XY Resolution	43 μm
Layer Thickness	0.01 - 0.30 mm
Avg. Printing Speed	400 layers / hr
Compatible File Format	.CTB / .PRZ
Power Requirement	100-240V AC ; 50-60Hz

## Hardware Specifications

Printer Size	47.5 x 40 x 68 cm
Printing Volume	33 x 18.5 x 40 cm
Printer Weight	35 kg

\* All specifications were tested in a laboratory and are subject to change without prior notice. For the latest update, please refer to Phrozen's official website.

\* The included power cord set packaged with the main unit cannot be used with electrical equipment other than the specified device.

## 03 Prepare Your 3D Printer

For first-time use, please thoroughly follow the steps below to conduct the LCD Test to make sure that your 3D printer is ready to print.

### LCD Test

- 1 Click on "TOOLS". Then click on "LCD TEST".
- 2 Check to see if the LCD screen displays the same image as seen on the touch panel.
- 3 When the LCD screen clearly displays all the images, the LCD TEST is complete.

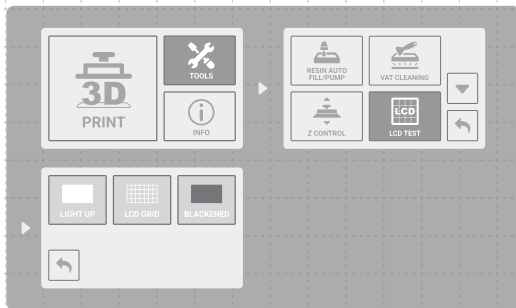

\* Please refer to the actual operation situation based on the printer display.

### Z-Offset Setting

Reposition your Z-Axis to print flat objects on the building plate. It is also helpful if the resin is viscous.

- 1 Tighten the screws on your resin vat and building plate. Make sure the building plate and resin vat are clean from any debris.
- 2 Click "Move to Z-Axis Zero Position"
- 3 Adjust the Z-Axis zero position based on your printing needs.
- 4 Click "Reset Z-Offset" then click on "SET" to complete the setting.

**Tips:** Reflashing the firmware and performing Move to Z-Axis Zero Position will reset the Z-Offset setting. Please check the Z-Offset setting before each printing.

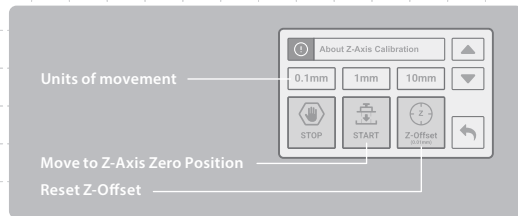

## Z-Axis Calibration

- 1** Remove the resin vat and the building plate. Clean the building plate and place it on a clean flat surface.
- 2** Loosen the 4 **cap screws** on the building plate, and loosen the 4 **set screws** until the gap is no longer visible. Check if the upper part of the building plate can make contact with the lower part.
- 3** Restore the building plate back onto the printer, Ensure that both the building plate and the LCD panel are clean and free of foreign objects.
- 4** Place an A4 paper on each side of the LCD panel. Click " Move to Z-axis zero point " and wait for the building plate to be leveled against the LCD panel.
- 5** Diagonally tighten the 4 **set screws** until they make contact with the blocks below. Then tighten the 4 **cap screws**.
- 6** Pull the A4 paper at the 4 corners to ensure equal friction between them to complete the Z-axis calibration.  
If the friction is uneven, simply loosen and tighten the 4 **cap screws** to adjust.

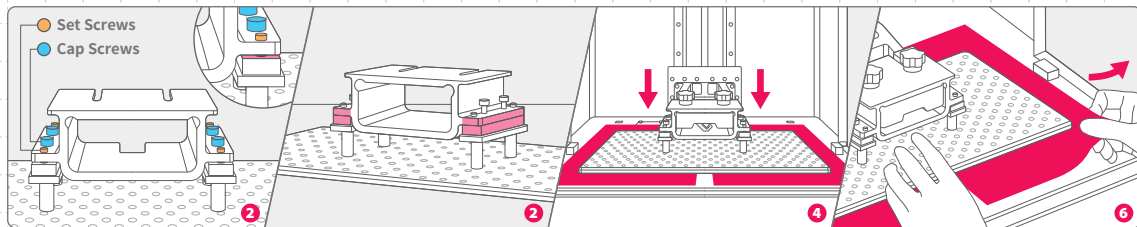



## 04 Prepare Your Print File

The Sonic Mega 8K V2 supports both .CTB and .PRZ file formats. Use slicer software to turn .STL and .OBJ files into .CTB or .PRZ files.

### Convert .STL/.OBJ File to .CTB/.PRZ File

- 1 Import .STL or .OBJ files into the slicer software and add supports to your models to secure them to the building plate.
- 2 Choose the "Sonic Mega 8K V2" printer in the slicer. Set the resin parameters according to your resin and slice.
- 3 After the slicing is completed, save it as a .CTB or .PRZ file and the file is ready to be printed.

### Test Files for Your First Print

- 1 The USB included in the toolbox contains both .STL and .CTB files of two test models: "Phrozen\_test" and "Phrozen\_XP\_Finder".
- 2 You can directly print the .CTB files in the USB with Aqua-Gray 8K Resin. If you are printing with other resins, slice the .STL files with the suitable parameter settings required for your resin.



Slicer Software



Supports Tutorial



Resin Parameters



Learn and Download  
Phrozen\_XP\_Finder

## 05 File Import & Ethernet

Sonic Mega 8K V2 can import files either via USB or via Ethernet.

### Import Files via USB

- 1 Save the .CTB or .PRZ file to your USB, and plug the USB into the printer.
- 2 On the "Print" menu on your touch panel, click "PRINT" > select the file you want to print > "Print".

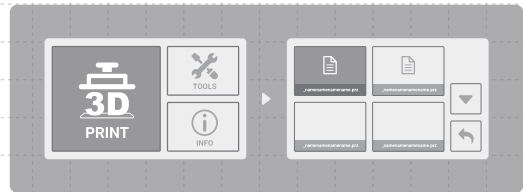

## Importing via Ethernet

- 1 Insert the USB and connect your printer to the same router as your computer.
- 2 Click on "TOOLS", and select "NETWORK" to check the IP address of the 3D printer.

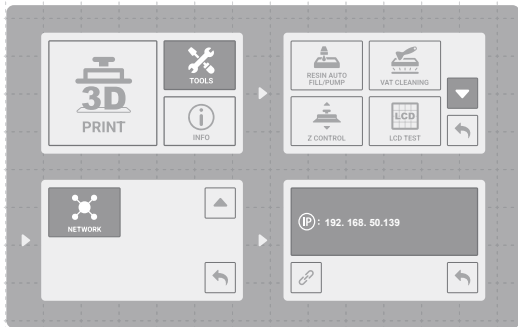

\* The IP address in this photo is for reference only.

- 3 Operate the CHITUBOX slicer on your computer. After slicing your 3D file, click on " Network Sending " to send your file to the printer.
- 4 Make sure to select the CHITUBOX slicer (\*.CTB or .PRZ) as your file type before sending it over to your 3D printer's IP address.
- 5 After successfully sending over your file, click on " OK " to start printing immediately.
- 6 If not, click on " Cancel ", the file will directly be stored onto the USB drive plugged into your printer.

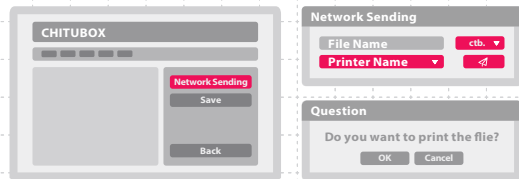

## 06 First Test Print

Use Aqua-Gray 8K Resin and the "Phrozen\_Mega\_XP\_Finder\_Mega8KV2\_AQ8K.ctb" file to perform the test.

- 1 Tighten the screws on your resin vat and building plate. Make sure the building plate and resin vat are clean from any debris.
- 2 Shake the resin bottle for 1 minute. Pour the resin into the vat without exceeding the maximum mark.
- 3 Insert the USB, find the test file named "Phrozen\_Mega\_XP\_Finder\_Mega8KV2\_AQ8K.ctb" and start printing it with Aqua-Gray 8K resin.
- 4 While printing, please keep the printer door closed to prevent light exposure that may affect your prints.
- 5 Once the printing is completed, carefully remove the building plate and use a metal scraper to carefully remove your print.
- 6 Use a 95% sanitizing alcohol or a Phrozen Wash Resin Cleaner to clean your printed models. After it's fully dried, post-cure your models with a Curing Station.

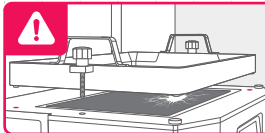
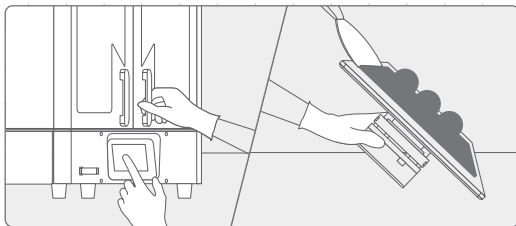
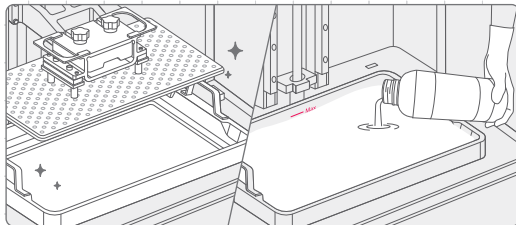

**NOTICE:** When installing the resin vat, please align the screws at the bottom of the resin vat with the platform grooves to avoid damage caused by the screws scratching the LCD panel.

## After-Sales Service & Warranty

- Phrozen offers a one-year warranty for all parts, excluding consumable components such as the LCD screen and vat film (ACF) .
- Sonic Mega 8K V2 LCD screen is covered under a 3-month warranty. Please note that this warranty does not cover any damages caused by human factors.
- If you encounter any difficulties, please scan the QR code to contact us.



Contact us !



# Congratulations!

You have just completed your first run.  
We hope you've had a great experience!

Please follow Phrozen's social media accounts  
and subscribe to our YouTube channel to learn  
more about printing tips and share information  
with the community.



Facebook



Facebook Group

Sonic Mega Series



YouTube



Instagram