

TAG: _____

SUBMITTAL

**1.5 Ton
Multi-position Air Handler
J4AH4P18A1A00AA**

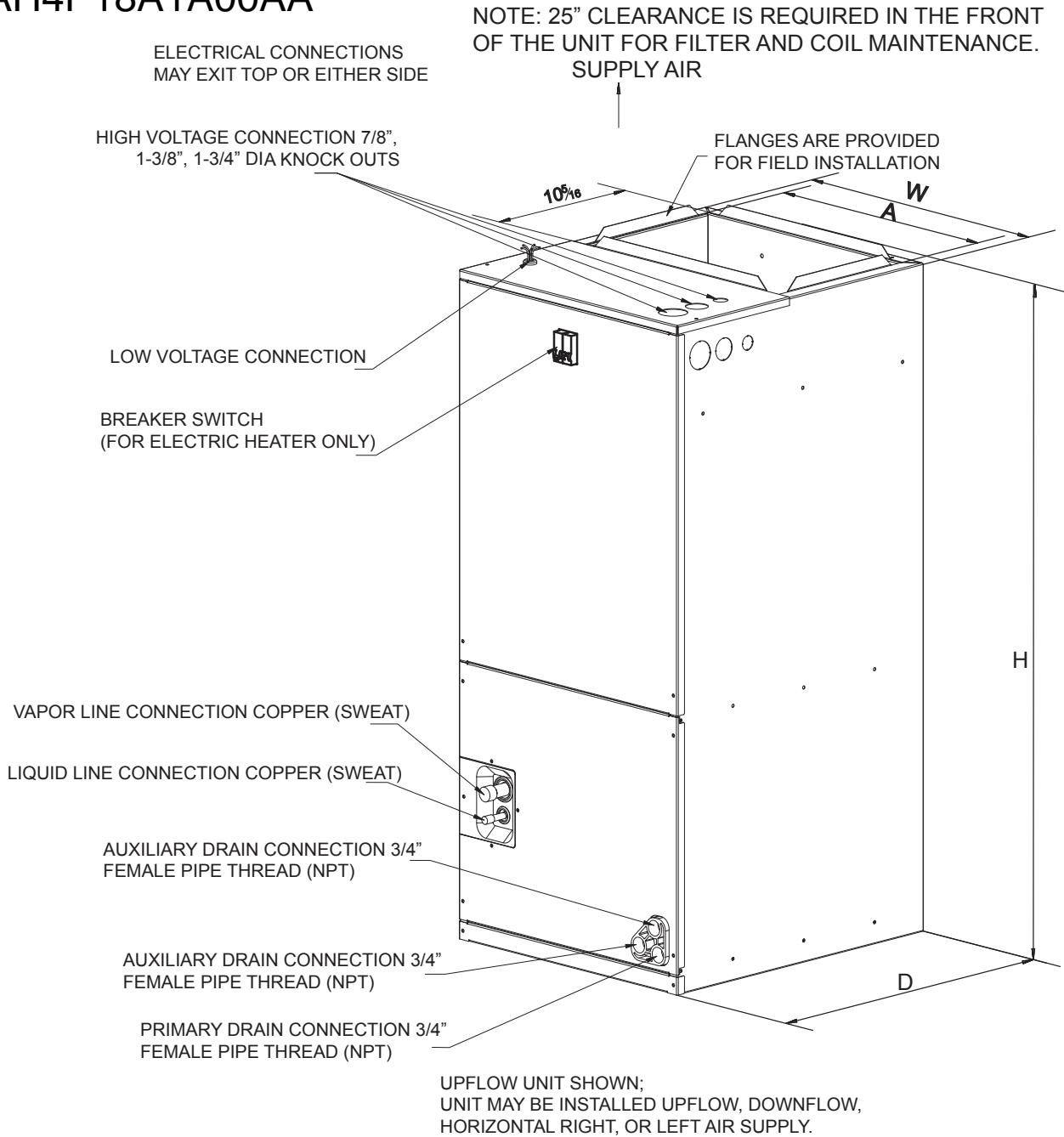

Fig.1 DIMENSIONS

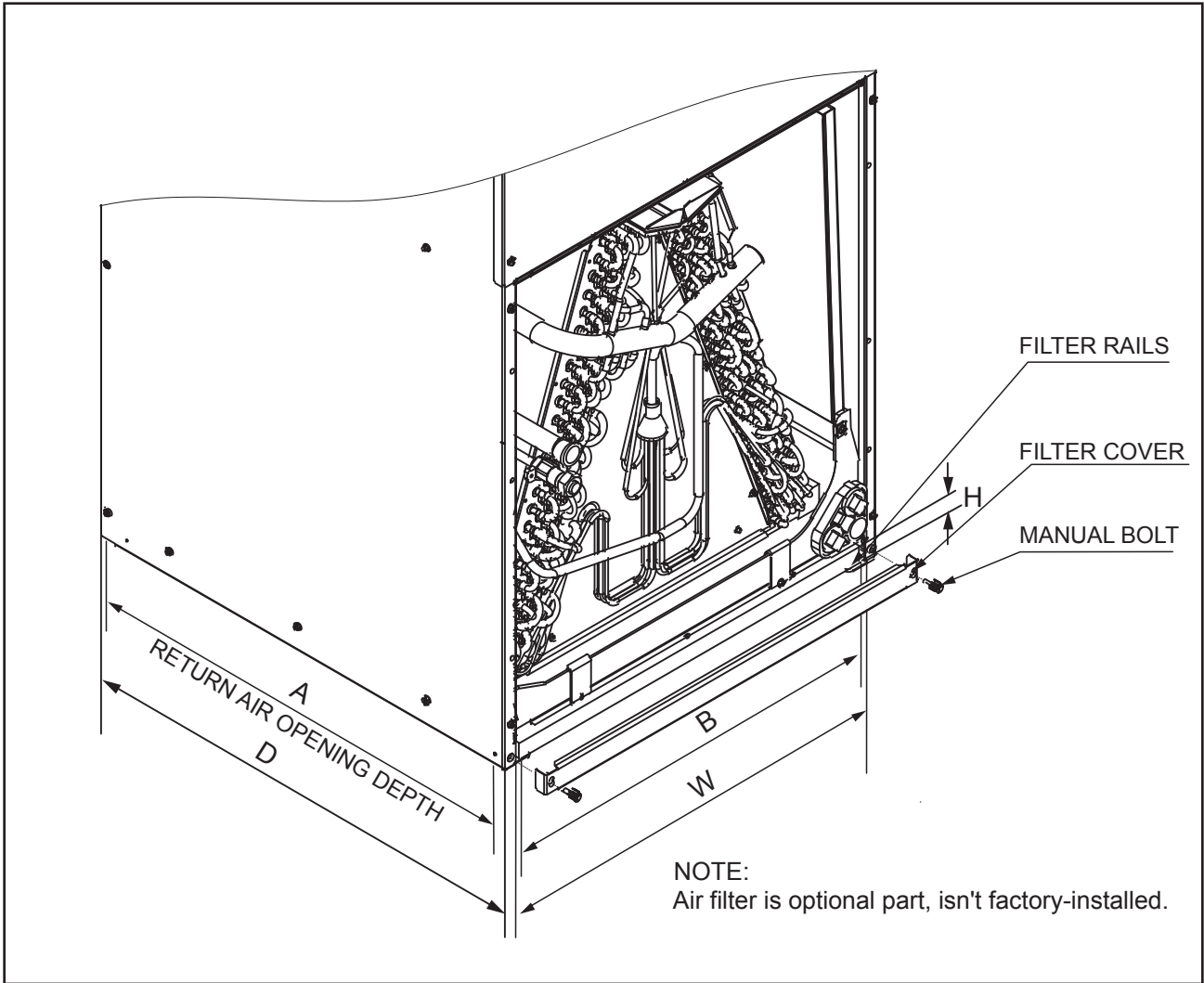

Fig.2 EXTERNAL FILTER BASE

NOTE: All dimensions are in mm/inches.

| Model | H | W | D | A | Return width A | Return length B |
|-----------------|---------------|--------------|-------------|---------|-------------------|--------------------|
| J4AH4P18A1A00AA | 1050 (41-3/8) | 460(18-1/18) | 520(20-1/2) | 406(16) | 498(19-3/5) | 376 (14-4/5) |

PRODUCT SPECIFICATIONS

PRODUCT SPECIFICATIONS

| | |
|-----------------------------------|---------------------------|
| MODEL | J4AH4P18A1A00AA |
| RATED VOLTS/PH/HZ. | 208-230/1/60 |
| RATINGS | See O.D. Specifications |
| INDOOR COIL — Type | Plate Fin |
| Rows — F.P.I. | 4 - 17 |
| Face Area (sq. ft.) | 2.99 |
| Tube Size (in.) | 9/32 |
| Refrigerant Control | Orifice |
| Drain Conn. Size (in.) | 3/4 NPT |
| DUCT CONNECTIONS | See Outline Drawing |
| INDOOR FAN — Type | Centrifugal |
| Diameter-Width (In.) | 10-5/8 X 8-1/8 |
| No. Used | 1 |
| Drive - No. Speeds | Direct - 3 |
| CFM vs. in. w.g. | See Fan Performance Table |
| No. Motors — H.P. | 1 - 1/8 |
| Motor Speed R.P.M. | 1075 |
| Volts/Ph/Hz | 208-230/1/60 |
| F.L. Amps | 1.4 |
| FILTER | |
| Filter Furnished? | No |
| Type Recommended | Throwaway |
| No.-Size-Thickness | 1 - 16 X 20 - 1 in. |
| REFRIGERANT | R-410A |
| Ref. Line Connections | Brazed |
| Coupling or Conn. Size — in. Gas | 3/4 |
| Coupling or Conn. Size — in. Liq. | 3/8 |
| DIMENSIONS | H x W x D |
| Crated (In.) | 42-7/10 x 21 x 24-1/6 |
| Uncrated | 41-3/8 x 18-1/8 x 20-1/2 |
| WEIGHT | |
| Shipping (Lbs.)/Net (Lbs.) | 117/104 |



| Heater Kit Model Used | Electric Heat (kW) | Min. Circuit Ampacity | | Max. Fuse or Breaker (HACR) Ampacity | | Minimum Heating Blower Speed | |
|-----------------------|--------------------|-----------------------|------|--------------------------------------|------|------------------------------|---------|
| | | 240V | 208V | 240V | 208V | Without HP | With HP |
| JAYHTR1A05BKR * | 5 | 27.9 | 24.4 | 30 | 25 | Low | Low |
| JAYHTR1A08BKR * | 7.5 | 40.9 | 35.7 | 45 | 40 | Low | Low |
| JAYHTR1A10BKR * | 10 | 53.9 | 47 | 60 | 50 | Low | Low |

Note: Factory set at Medium Speed.

| Motor Speed | AIR FLOW PERFORMANCE | | | | | | | | | |
|-------------|--|------|----------|----------|----------|----------|----------|----------|----------|----------|
| | J4AH4P18A1A00AA | | | | | | | | | |
| | External Static Pressure-Inches W.C. (kPa) | | | | | | | | | |
| | | 0(0) | 0.1(.02) | 0.2(.05) | 0.3(.07) | 0.4(.10) | 0.5(.12) | 0.6(.15) | 0.7(.17) | 0.8(.20) |
| Low | CFM | 563 | 498 | 434 | 373 | 317 | 246 | 217 | - | - |
| Medium | CFM | 695 | 633 | 576 | 509 | 457 | 388 | 318 | 240 | 231 |
| High | CFM | 927 | 872 | 815 | 761 | 697 | 633 | 566 | 510 | 380 |

Mechanical Specifications

- Unique Cabinet Design
- Metal shell and glass cotton thermal insulation layer
- Multi-Position UP/Down Flow Horizontal Left /Right
- Braze in Refrigerant Connection
- Primary/Secondary Condensate Connections
- Blower with Integrated Slide Deck for Easy Removal
- Inner-groove aluminum tube and high-efficiency aluminum fin Coil with Integrated Slide Deck for Easy Removal
- More auxiliary Electric Heaters optional
- PSC 3 Speed Motor
- High Efficiency
- Integrated Horizontal Drain pans and metal Vertical Drain
- Fused 24V Power
- 5-Year Warranty.
- Warranty Mirrors Outdoor.
- Optional extended warranty available.
- Suitable for Manufactured/Mobile Home Use.

OXBOX[™]
A TRANE® BRAND



The manufacturer has a policy of continuous product and product data improvement and it reserves the right to change design and specification without notice.

BX-PRQ-J4AH4P18A1A00A-1A