

TAG: \_\_\_\_\_

**SUBMITTAL**

**3.5 Ton Split System  
Air Conditioner - 1 Phase  
J4AC5042E1000AA**

Product Specifications

OUTDOOR UNIT	J4AC5042E1000AA
POWER CONNS. — V/PH/HZ	208/230/1/60
MIN. BRCH. CIR. AMPACITY	24.9
BR. CIR. PROT. RTG. - MAX. (AMPS)	45
COMPRESSOR	SCROLL
NO. USED - NO. SPEEDS	1 - 1
VOLTS/PH/HZ	208/230/1/60
R.L. AMPS - L.R. AMPS	18.1 - 112
FACTORY INSTALLED START COMPONENTS	NO
INSULATION/SOUND BLANKE T	NO
COMPRESSOR HEAT	NO
OUTDOOR FAN	PROPELLER
DIA. (IN.) - NO. USED	23 - 5/8
TYPE DRIVE - NO. SPEEDS	EXTERNAL - 10
CFM @ 0.0 IN. W.G.	3600
NO. MOTORS - HP	1 - 1/3
MOTOR SPEED R.P.M.	980
VOLTS/PH/HZ	208/230/1/60
F.L. AMPS	2.2
OUTDOOR COIL — TYPE	PLATE FIN
ROWS - F.P.I.	2 - 21
FACE AREA (SQ. FT.)	18.4
TUBE SIZE (IN.)	3/16
REFRIGERANT CONTROL	TXV
REFRIGERANT	
LBS. — R-410 (O.D. UNIT)	8 LBS. - 1 OZ.
FACTORY SUPPLIED	YES
LINE SIZE - IN. O.D. GAS	7/8
LINE SIZE - IN. O.D. LIQ.	3/8
CHARGING SPECIFICATION	
SUBCOOLING	9° F
DIMENSIONS	W X H X D
CRATED (IN.)	30-1/5×38-1/5×30-1/5
WEIGHT	
SHIPPING (LBS.)	218
NET (LBS.)	191

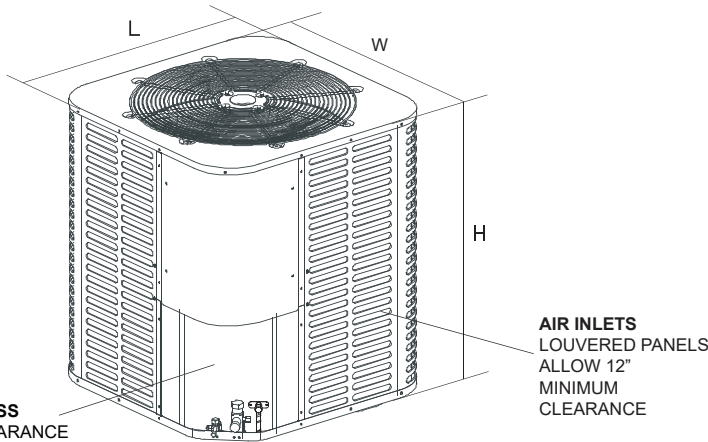

**SERVICE ACCESS**  
ALLOW 24" CLEARANCE

**AIR INLETS**  
LOUVERED PANELS  
ALLOW 12"  
MINIMUM  
CLEARANCE

**NOTE:** GRILL APPEARANCE  
MAY VARY.

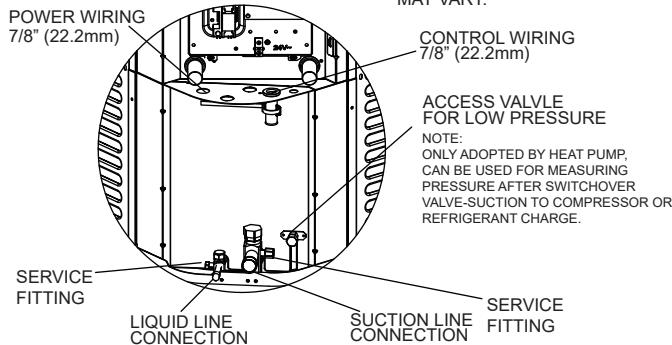

POWER WIRING  
7/8" (22.2mm)

CONTROL WIRING  
7/8" (22.2mm)

ACCESS VALVLE  
FOR LOW PRESSURE

**NOTE:**  
ONLY ADOPTED BY HEAT PUMP.  
CAN BE USED FOR MEASURING  
PRESSURE AFTER SWITCHOVER  
VALVE-SUCTION TO COMPRESSOR OR  
REFRIGERANT CHARGE.

SERVICE  
FITTING

LIQUID LINE  
CONNECTION

SUCTION LINE  
CONNECTION

SERVICE  
FITTING

NOTE: All dimensions are in mm/inches.

Model	H	W	L	LIQUID VALVE SIZE	GAS VALVE SIZE
J4AC5042E1000AA	843(33-3/16)	740(29-1/8)	740(29-1/8)	3/8	7/8

# Mechanical Specification Options

---

## **General**

The J4AC50 is fully charged from the factory. This unit is designed to operate at outdoor ambient temperatures as high as 115°F. Cooling capacities are matched with air handlers and furnace coils that are AHRI certified. The unit is certified to ETL. Exterior is designed for outdoor application.

## **Casing**

Unit casing is constructed of heavy gauge, Galvanized steel and painted with a weather-resistant powder paint on all grilles, panels, pre-paint on all other panels. And had 500-hours salt spray tested.

## **Refrigerant Controls**

Refrigeration system controls include condenserfan, compressor contactor.

## **Compressor**

Features include low vibration and noise.

## **Condenser Coil**

The outdoor coil provides low airflow resistance and efficient heat transfer. The coil is protected on all four sides by grille panels.

## **Optional accessories**

### **Liquid line drier —**

It is used to filter out impurities and water in the system, ensures system clean and dry.



---

*OXBOX has a policy of continuous product and product data improvement and it reserves the right to change design and specifications without notice.*

**BX-PRQ-J4AC5042E1000A-1A**