

Artemide®

Gople

by Bjarke Ingels Group

WEWORK SCHOOL, NEW YORK, USA  
Photo Credit : Dave Burk



# Gople

Bjarke Ingels Group  
↪ 2019

BIG is a group of architects, designers and thinkers operating within the fields of architecture, urbanism, research and development with offices in Copenhagen and New York City. BIG has created a reputation for completing buildings that are as programmatically and technically innovative as they are cost and resource conscious, incorporating overlapping design disciplines for a new paradigm in architecture. BIG believe strongly in research as a design tool.





## ↗ Murano Glass

A powerful LED light source is housed within a handblown glass diffuser, produced according to ancient Venetian glass-blowing techniques and created in Murano. The soft glass helps diffuse a soft glow, as light fills the pill shaped diffuser. The diffuser is available in three options: crystal glass with a white gradient, transparent glass with a silver or copper metallic finish.

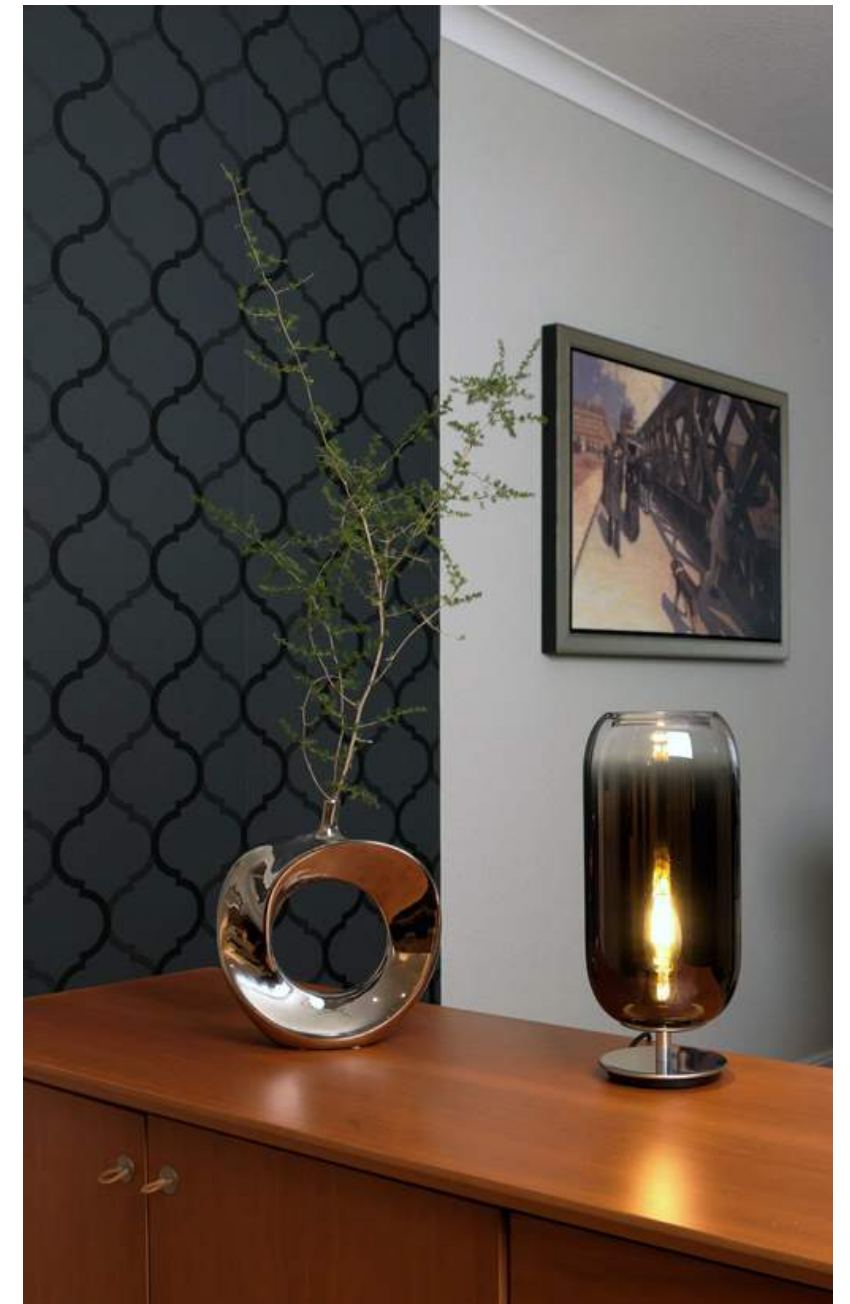

Gople  
↪ Light Off



Gople  
↪ Light On



BIG OFFICES, COPENHAGEN, DENMARK





## ↗ The Human Light

Gople Lamp is the perfect example of Artemide's guiding philosophy of "The Human Light". It aspires to create light that is good for the wellness of man and for the environment that has a positive impact on our quality of life.





## ↗ Gople Typologies

The human and responsible light goes hand in hand with design and material savoir-faire, combining next-generation technology with ancient techniques. It is a perfect expression of sustainable design. The end result is a product that

delivers both visual comfort and aesthetic value, while contributing to the wellness of both man and the environment. Gople is now available in a complete product family with suspension, ceiling, floor, and table versions.

Gople Suspension



Gople Mini Suspension



Gople Table



Gople Mini Table



Gople Floor



Gople Ceiling



Gople Mini Ceiling





# ↗ Gople

## Technical Data

### Gople Suspension

- White
- Chrome
- Copper
- Bronze
- Blue

Chrome metal canopy  
 Diffuser in handblown glass

LED-T (non integrated only) E26 / A19  
 Dimmable (wall switch)



W	Voltage
22W	120V



Standard length  
 Min 36<sup>1/4</sup>" Max 48"  
 Min 92 cm Max 122 cm

Extended length  
 Min 36<sup>1/4</sup>" Max 230"  
 Min 92 cm Max 548 cm

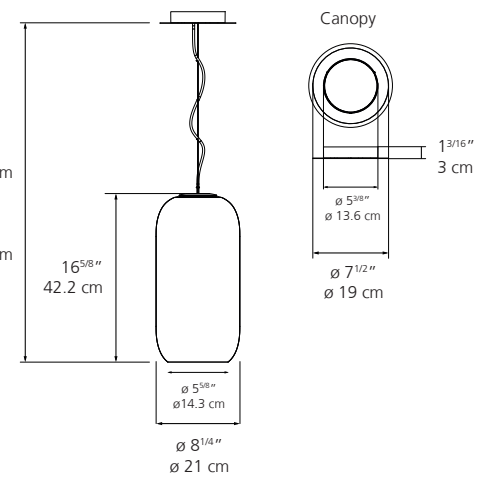

### Gople Mini Suspension

- White
- Chrome
- Copper
- Bronze
- Blue

Chrome metal canopy  
 Diffuser in handblown glass

LED-T (non integrated only) E12 / G16.5  
 Dimmable 2-Wire / Dimmable



W	Voltage
7W	120V



Standard length  
 Min 36<sup>1/4</sup>" Max 48"  
 Min 92 cm Max 122 cm

Extended length  
 Min 36<sup>1/4</sup>" Max 230"  
 Min 92 cm Max 548 cm

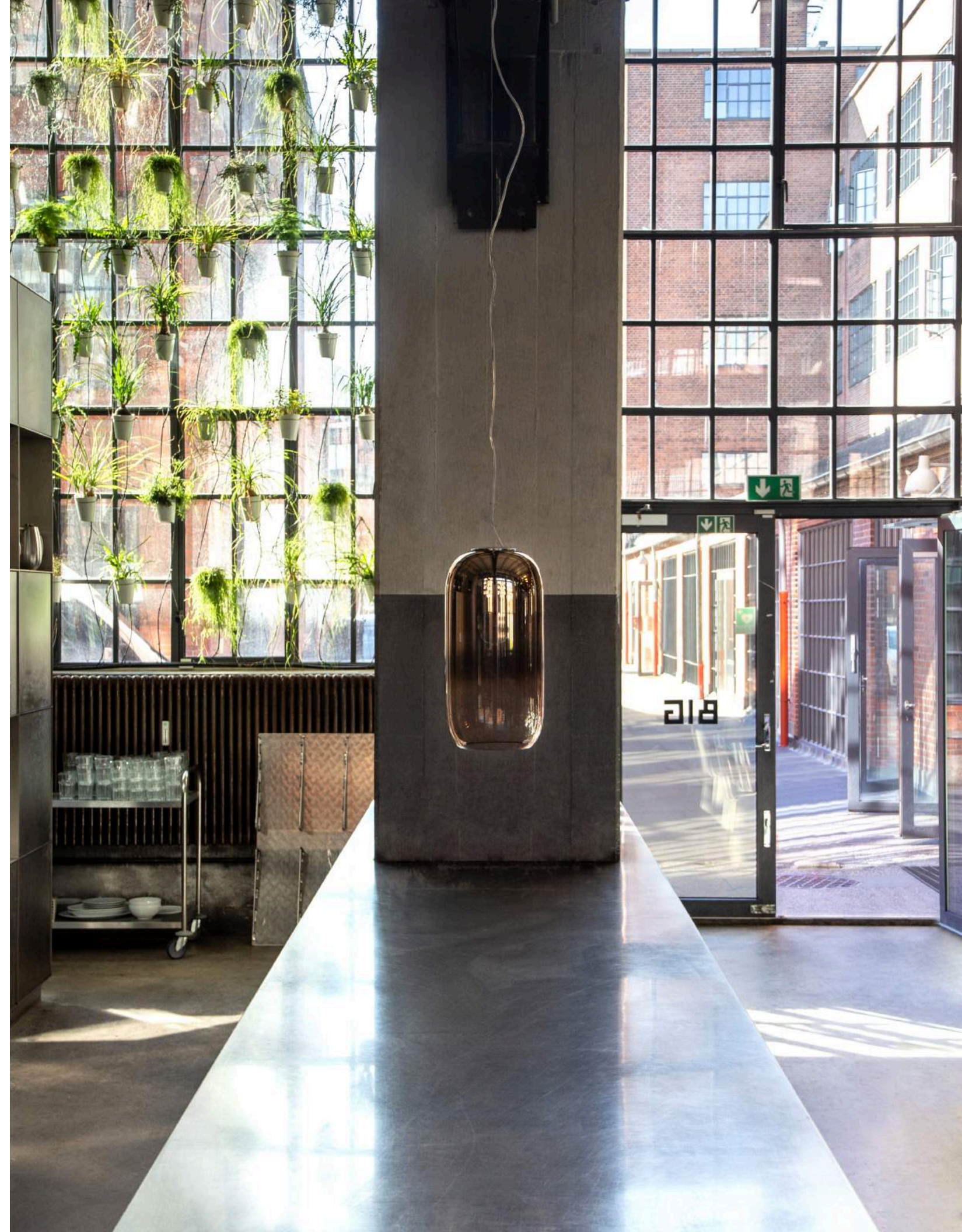
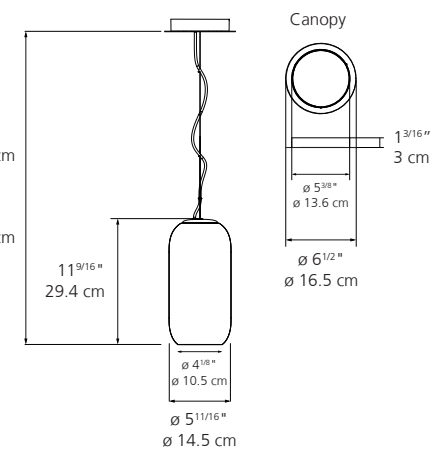





# ↗ Gople

## Technical Data

### Gople Table

- White
- Chrome
- Copper
- Bronze
- Blue

Diffuser in handblown glass  
Stem & base in chrome metal

LED-T (non integrated only) E26 / A19  
Dimmable (on cord)



W	Voltage
20W	120V

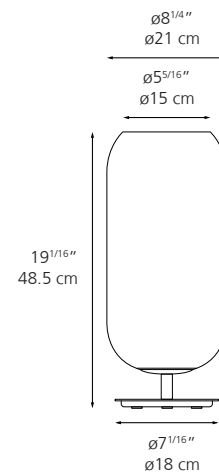

### Gople Mini Table

- White
- Chrome
- Copper
- Bronze
- Blue

Diffuser in handblown glass  
Stem & base in chrome metal

LED-T (non integrated only) E12 / G16.5  
Dimmable (on cord)



W	Voltage
7W	120V

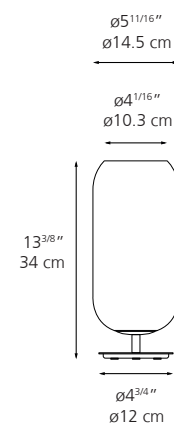

# ↗ Gople

## Technical Data

### Gople Floor

- White
- Chrome
- Copper
- Bronze
- Blue

Diffuser in handblown glass  
Stem & base in chrome metal

LED-T (non integrated only) E26 / A19  
Dimmable (on cord)



W	Voltage
22W	120V

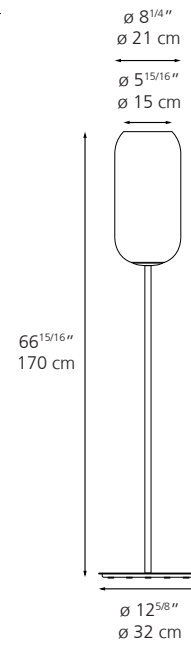

# ↗ Gople

## Technical Data

### Gople Ceiling

- White
- Chrome
- Copper
- Bronze
- Blue

Chrome metal canopy  
Diffuser in handblown glass

LED-T (non integrated only) E26 / A19  
Dimmable



W	Voltage
20W	120V

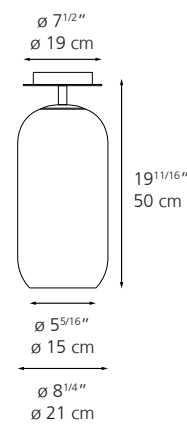

### Gople Mini Ceiling

- White
- Chrome
- Copper
- Bronze
- Blue

Chrome metal canopy  
Diffuser in handblown glass

LED-T (non integrated only) E12 / G16.5  
Dimmable



W	Voltage
7W	120V

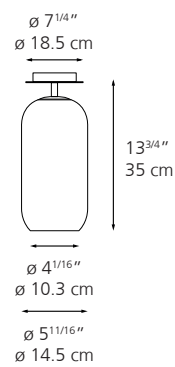





## Artemide INC

250 Karin Lane  
Hicksville, NY 11801  
Tel. 631-694-9292  
artemide.net

## Artemide LTD

11105 rue Renaude Lapointe  
Montréal, Québec, H1J 2T4  
Tel. 514-323-6537  
artemide.net



ISO 9001:2015



ISO 14001:2015



ISO 45001:2018



**CTF STAGE2  
ISO 17025**

### Artemide INC - Artemide LTD

Si riserva la facoltà di modificare, in qualunque momento e senza preavviso, le caratteristiche tecniche degli elementi illustrati nel presente catalogo.

### Artemide INC - Artemide LTD

Reserves right to change, at any time and without prior warning, the technical specifications of any product illustrated in this catalogue.

### Artemide INC - Artemide LTD

Se réserve le droit de modifier, à n'importe quel moment et sans préavis, les caractéristiques techniques des éléments illustrés dans ce catalogue.

### Artemide INC - Artemide LTD

Behält sich das recht vor jederzeit und ohne ankündigung die technischen daten der im katalog abgebildetem produkte zu ändern.

### Artemide INC - Artemide LTD

Se reserva la facultad de modificar, en cualquier y sin aviso previo, las características técnicas de los elementos ilustrados en el presente catálogo.