



X-LARGE CERAMIC FUNNEL PENDANT LIGHT

The funnel light pendants are made and assembled by hand in Philadelphia. Each light is made of stoneware, glazed with a white gloss glaze and finished with a darkened brass loop and chain. This series achieves multiple silhouettes with an assortment of shapes and sizes that are used to create a custom collection.

Natalie Page • Email sales@nataliepage.com • Instagram @npagestudio
3747 Ridge Ave., Philadelphia, PA 19132



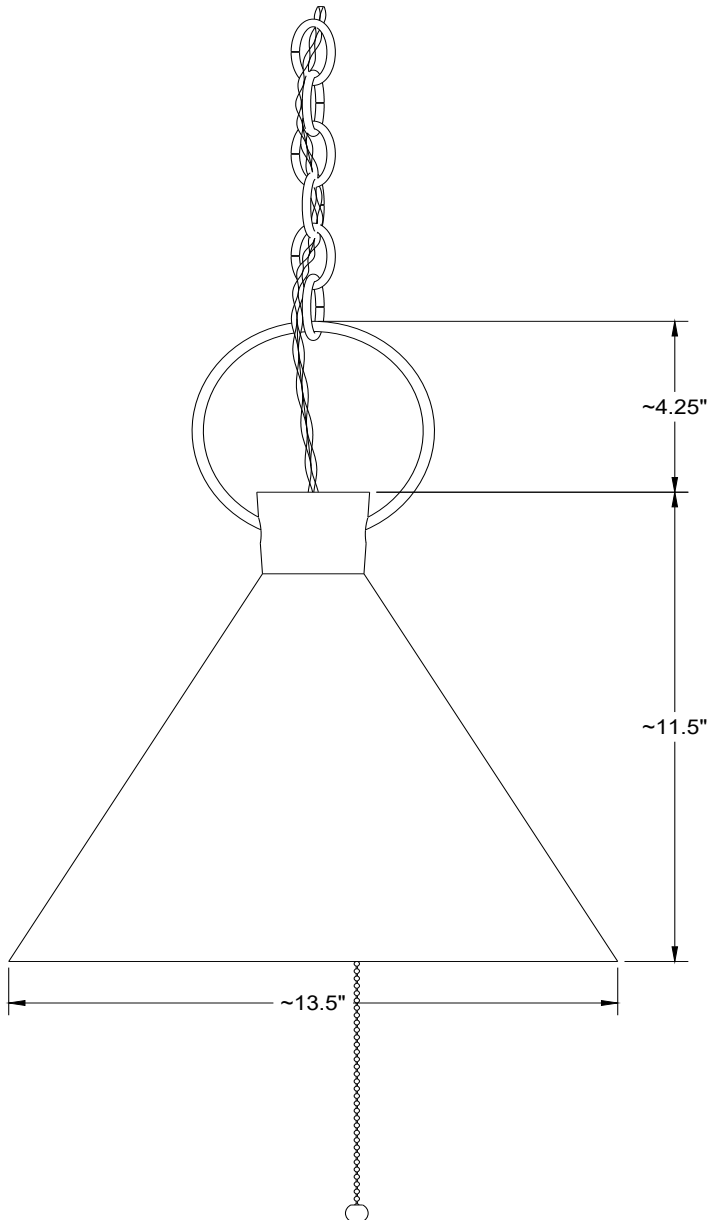

DIMENSIONS:

- Ceramic Shade: ~13.5" D x ~11.5" H
- Brass Loop: ~5.25" D

MATERIALS:

Ceramic shade , brass loop, patinated chain, twisted cloth cord, pull chain socket

LEAD TIME:

6-10 weeks approximately

LAMPING:

- 60W LED equivalent max
- 40W incandescent E26 bulb
- Voltage: 120-250

NOTES:

- UL approve upon request
- Plug at end unless canopy is requested
- CE sockets do not have pull chains
- Brass loop dimension will vary
- Size, shape, and glaze color will vary
- Standard 9 ft. chain, 12 ft. wire

