



3XL CERAMIC FUNNEL PENDANT LIGHT

The funnel light pendants are made and assembled by hand in Philadelphia. Each light is made of stoneware, glazed with a white gloss glaze and finished with a darkened brass loop and chain. This series achieves multiple silhouettes with an assortment of shapes and sizes that are used to create a custom collection.

Natalie Page • Email [sales@nataliepage.com](mailto:sales@nataliepage.com) • Instagram @npagestudio  
3747 Ridge Ave., Philadelphia, PA 19132



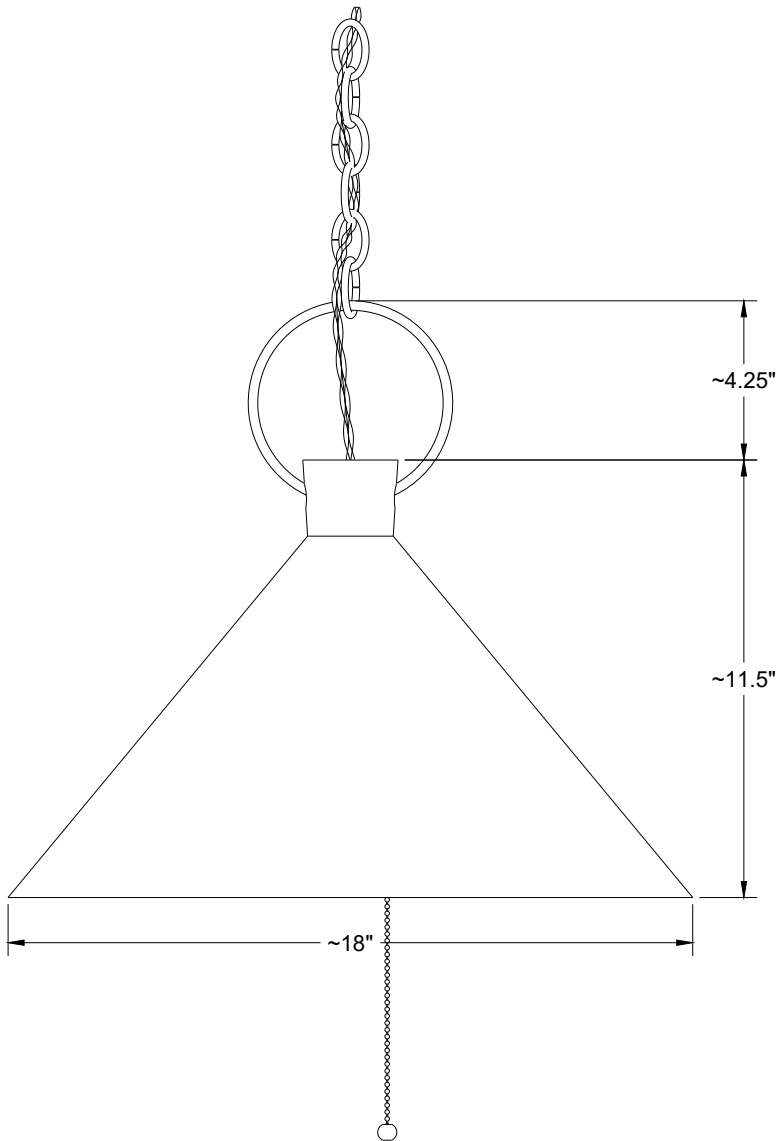

**DIMENSIONS:**

- Ceramic Shade: ~18" D x ~11.5" H
- Brass Loop: ~5.25" D

**MATERIALS:**

Ceramic shade , brass loop, patinated chain, twisted cloth cord, pull chain socket

**LEAD TIME:**

8-10 weeks approximately

**LAMPING:**

- 60W LED equivalent max
- 40W incandescent E26 bulb
- Voltage: 120-250

**NOTES:**

- UL approval upon request
- Plug at end unless canopy is requested
- CE sockets do not have pull chains
- Brass loop dimension will vary
- Size, shape, and glaze color will vary
- Standard 9 ft. chain, 12 ft. wire

