



USBC-HS-UART

USB 2.0 Type C Hi-Speed to UART

Datasheet



Document Reference No.: CP_000065

Version 1.3

Connective Peripherals Pte Ltd
1 Tai Seng Avenue, Tower A, #03-05, Singapore 536464
Tel.: +65 67430980

E-Mail (Support): support@connectiveperipherals.com Web: www.connectiveperipherals.com/products

Neither the whole nor any part of the information contained in, or the product described in this manual, may be adapted or reproduced in any material or electronic form without the prior written consent of the copyright holder. This product and its documentation are supplied on an as-is basis and no warranty as to their suitability for any particular purpose is either made or implied. Connective Peripherals Pte Ltd will not accept any claim for damages howsoever arising as a result of use or failure of this product. Your statutory rights are not affected. This product or any variant of it is not intended for use in any medical appliance, device or system in which the failure of the product might reasonably be expected to result in personal injury. This document provides preliminary information that may be subject to change without notice. No freedom to use patents or other intellectual property rights is implied by the publication of this document. Connective Peripherals Pte Ltd, 1 Tai Seng Avenue, Tower A, #03-05, Singapore 536464. Registered Number: 201617872E

1 Description

1.1 Functional Description

The **USBC-HS-UART** cable provides a fast, simple way to connect devices with 3.3 volt digital interfaces to USB Type C.

The USBC-HS-UART contains a small internal electronic circuit board, utilising the FT232H, which is encapsulated into the USB Type C connector end of the cable. The FT232H handles the USB signalling and protocols. The FT232H is a single channel USB 2.0 Hi-Speed (480Mb/s) to UART IC. For full details, features and enhancement descriptions please refer to [FT232H datasheet](#).

The digital interface of the cable is made up of ten individual wires which are terminated with single pole connectors which can be connected next to each other on a male header. The cables digital interface logic is 3.3 volts.

The USB Type C side of the cable is USB powered and is USB 2.0 Hi-Speed compatible. The cable is 1.8m long and supports a data transfer rate up to 12 MBaud.

The USBC-HS-UART requires USB device drivers, available free from Windows Update or from <https://connectiveperipherals.com> which used to make the FT232H in the cable appear as a virtual COM port (VCP). This then allows the user to communicate with the USB Type C interface via a standard PC serial emulation port (for example TTY).

Another USB driver, the D2XX, is used with application software to directly access the FT232H on the cable though a DLL. This is illustrated in the Figure 1-1.

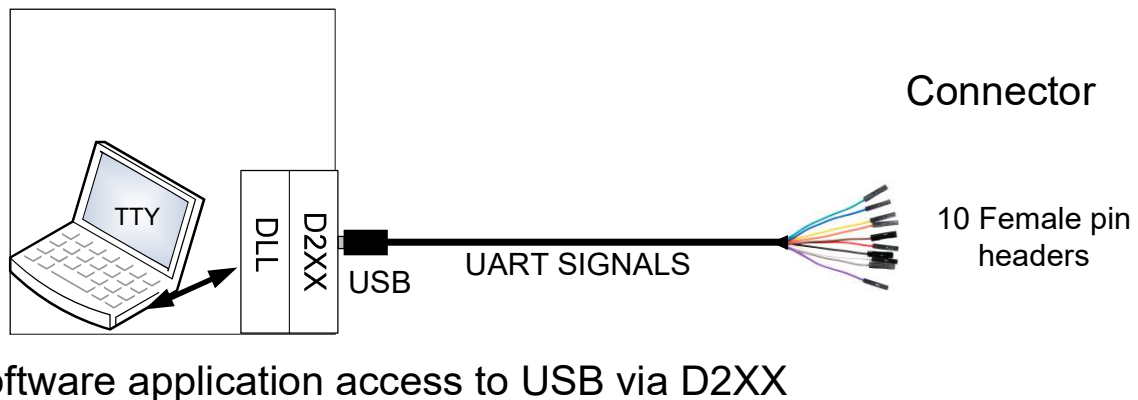
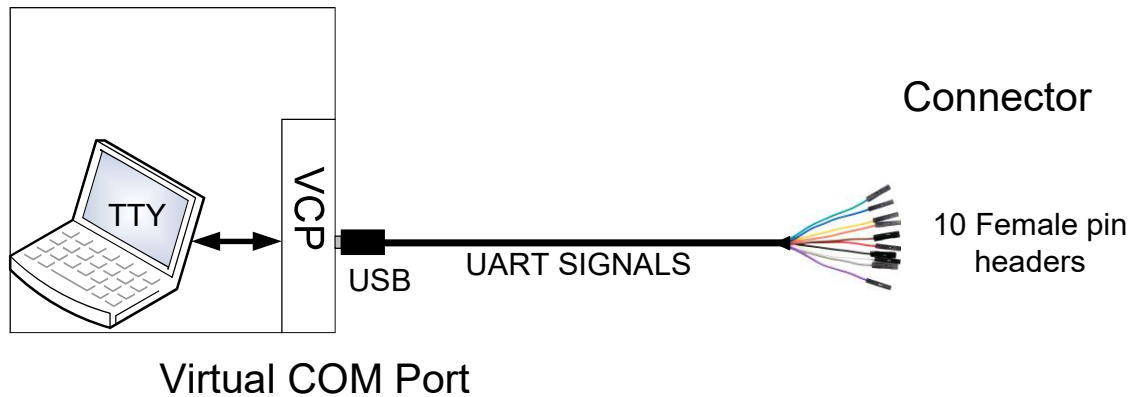

Figure 1-1 Using the USBC-HS-UART

1.2 Part Numbers

The following Table 1.1 gives details of the USBC-HS-UART part numbers.

Part Number	Description	End Connector	Cable details
USBC-HS-UART-3.3V-3.3V-1800-SPR	USB Type C to UART with +3.3V digital level signals. Maximum output of 250mA @ 3.3VDC on VCC (see Note 1)	Single pole, receptacle x 10	10 core, UL2464 26 AWG, diameter=6.0mm length = 1800mm black
USBC-HS-UART-5V-3.3V-1800-SPR	USB Type C to UART with +3.3V digital level signals. Maximum output of 450mA @ 5.0VDC on VCC (see Note 2)	Single pole, receptacle x 10	10 core, UL2464 26 AWG, diameter=6.0mm length = 1800mm black

Table 1.1 USBC-HS-UART Descriptions and Part Numbers

Note 1: The VCC power output signal (RED wire) is 3.3V. The source of 3.3V is the on-board regulator Output, which is switched onto the power output signal.

Note 2: The VCC power output signal (RED wire) is 5.0V. The source of 5.0V is the USB VBUS input, which is switched onto the power output signal.

CP supports customised end connector designs. For more information, please contact your local CP sales office (see section 5 for contact details).

1.3 Certifications

The USBC-HS-UART are fully RoHS compliant as well as CE and FCC certified.

1.4 USB Compliant

The USBC-HS-UART are fully compliant with the USB 2.0 specification and have been given the USB-IF Test-ID (TID) 10820025.



Table of Contents

1	Description.....	2
1.1	Functional Description	2
1.2	Part Numbers.....	3
1.3	Certifications	3
1.4	USB Compliant	3
2	Typical Applications	5
2.1	Driver Support	5
2.2	Driver Installation.....	5
	Features.....	6
3	USBC-HS-UART connection and Mechanical Details.....	7
3.1	USBC-HS-UART Cable Signal Descriptions	8
3.2	USBC-HS-UART Signal Descriptions	9
3.3	USBC-HS-UART Electrical Parameters	9
3.3.1	USBC-HS-UART-3.3V-3.3V-1800-SPR Electrical Parameters	9
3.3.2	USBC-HS-UART-5V-3.3V-1800-SPR Electrical Parameters.....	9
3.3.3	USBC-HS-UART-3.3V-3.3V-1800-SPR & USBC-HS-UART-5V-3.3V-1800-SPR I/O Characteristics	9
4	Cable PCB Circuit Schematic.....	11
5	Contact Information.....	13
	Appendix A - Cable EEPROM Configuration	14
	Appendix B - References	15
	Document References	15
	Acronyms & Abbreviations	15
	Appendix C - List of Figures and Tables	16
	List of Figures	16
	List of Tables	16
	Appendix D – Revision History	17

2 Typical Applications

- Interfacing MCU / PLD / FPGA based designs to USB
- USB Medical applications
- Rapid USB integration into existing electronic systems
- Prototyping platform for USB interface on new systems
- USB to RS232 / RS422 Converters
- Set Top Box PC - USB interface
- USB Hardware Modems
- USB Wireless Modems
- USB Bar Code Readers
- USB Industrial Control
- Upgrading Legacy Peripherals to USB Type C
- USB Instrumentation

2.1 Driver Support

Royalty free VIRTUAL COM PORT (VCP) DRIVERS for...

- Windows 11, 10, 8.x, 7
- Windows XP (legacy)
- Windows CE 4.2, 5.0 and 6.0 (Legacy)
- macOS 10.9 and above
- Linux 2.4 and greater

Royalty free D2XX Direct Drivers (USB Drivers + DLL S/W Interface)

- Windows 11, 10, 8.x, 7
- Windows XP (legacy)
- Windows CE 4.2, 5.0 and 6.0 (Legacy)
- macOS 10.9 and above
- Linux 2.4 and greater

The drivers listed above are all available to download for free from <https://connectiveperipherals.com>. Various 3rd Party Drivers are also available for other operating systems. Refer to <https://connectiveperipherals.com> and www.ftdichip.com for details.

2.2 Driver Installation

For driver installation and troubleshooting, please refer to the **Connective Peripherals USB to Serial Converters Driver Installation Guide (CP_000084)** which is available from www.connectiveperipherals.com.

2.3 Features

- Based on the single chip USB Hi-Speed FT232H device
- USB 2.0 Hi-Speed (480Mbps/Second) and Full Speed (12Mbps/Second) compatible
- Entire USB protocol handled on the chip – No USB-specific firmware programming required
- USB Type C connector for direct connection to USB TYPE C host or hub
- USB bus powered
- Asynchronous UART transfer data rate up to 12Mbaud
- UART interface support for 7 or 8 data bits, 1 or 2 stop bits and odd / even / mark / space / no parity
- Fully assisted hardware or X-On / X-Off software handshaking
- 1kByte receive and transmit buffers for high data throughput
- Adjustable receive buffer timeout
- Support for USB suspend and resume
- Low operating and USB suspend current
- Low USB bandwidth consumption
- UHCI / OHCI / EHCI host controller compatible
- -40°C to +85°C operating temperature range
- Cable length is 1.8m (6 feet)
- Custom versions also available (subject to Minimum Order Quantity (MOQ))
- Royalty-free VCP and D2XX drivers eliminate the requirement for USB driver development in most cases

3 USBC-HS-UART connection and Mechanical Details

The following Figure 3-1 shows the cable signals and the wire colours for these signals on the USBC-HS-UART.

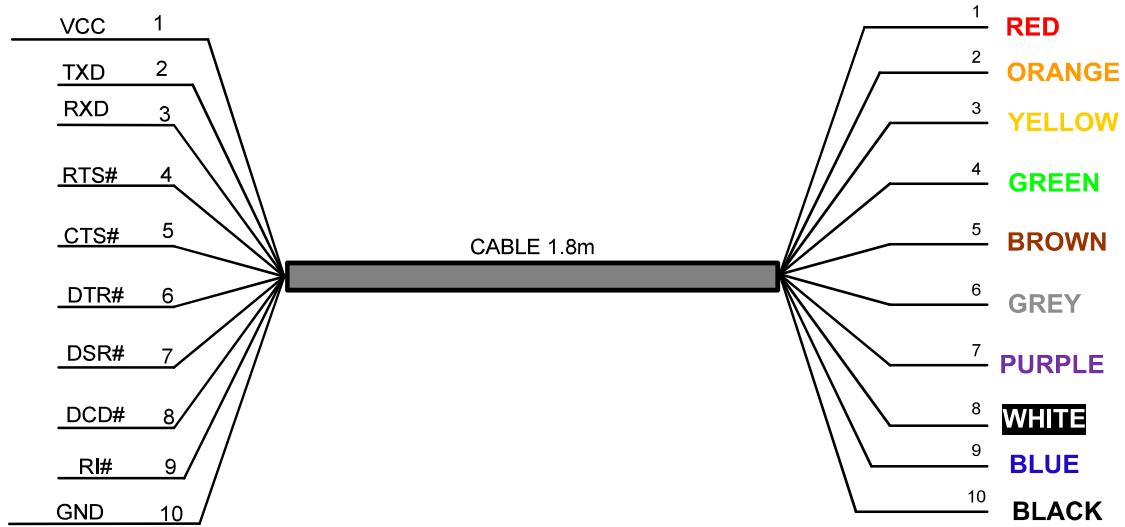

Figure 3-1 USBC-HS-UART Connections (numbers refer to pad numbers on the PCB)

3.1 USBC-HS-UART Cable Signal Descriptions

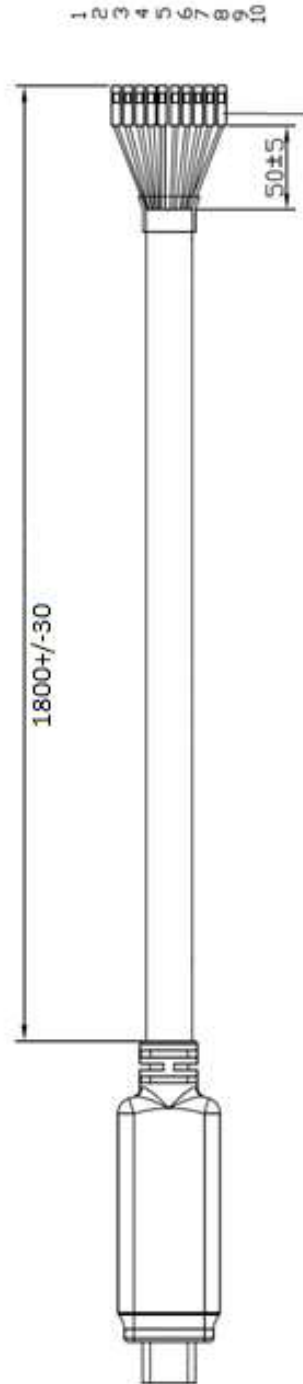

Figure 3-2 USBC-HS-UART Mechanical Details (dimensions in mm)

3.2 USBC-HS-UART Signal Descriptions

Colour	Pin Number	Name	Type	Description
Red	1	VCC	Output	Power Supply Output to target board.
Orange	2	TXD	Output	Transmit Asynchronous Data output.
Yellow	3	RXD	Input	Receive Asynchronous Data input.
Green	4	RTS#	Output	Request To Send Control Output / Handshake signal.
Brown	5	CTS#	Input	Clear to Send Control input / Handshake signal.
Gray	6	DTR#	Output	Data Transmit Ready modem signalling line
Purple	7	DSR#	Input	Data Set Ready modem signalling line
White	8	DCD#	Input	Data Carrier Detect modem signalling line
Blue	9	RI#	Input	RI# = Ring Indicator Control Input. When the Remote Wake up option is enabled in the EEPROM, taking RI# low can be used to resume the PC USB Host controller from suspend.
Black	10	GND	GND	Device ground supply pin.

Table 3.1 USBC-HS-UART Signal Descriptions

3.3 USBC-HS-UART Electrical Parameters

3.3.1 USBC-HS-UART-3.3V-3.3V-1800-SPR Electrical Parameters

Parameter	Description	Minimum	Typical	Maximum	Units	Conditions
VCC	Output Power Voltage	3.2	3.3	3.6	V	
I _o	Output Power Current	-	-	250	mA	
T	Operating Temperature Range	-40		+85	°C	

Table 3.2 USBC-HS-UART-3.3V-3.3V-1800-SPR

3.3.2 USBC-HS-UART-5V-3.3V-1800-SPR Electrical Parameters

Parameter	Description	Minimum	Typical	Maximum	Units	Conditions
VCC	Output Power Voltage	4.75	5	5.25	V	
I _o	Supply Current	-	-	450	mA	Must be less than 2.5mA during suspend.
T	Operating Temperature Range	-40		+85	°C	

Table 3.3 USBC-HS-UART-5V-3.3V-1800-SPR Power Supply Output Parameters

3.3.3 USBC-HS-UART-3.3V-3.3V-1800-SPR & USBC-HS-UART-5V-3.3V-1800-SPR I/O Characteristics

Parameter	Description	Minimum	Typical	Maximum	Units	Conditions
V _{oh}	Output Voltage High	2.40	3.14		V	I _{oh} = +/-2mA I/O Drive strength* = 4mA
			3.20		V	I/O Drive strength* = 8mA
			3.22		V	I/O Drive strength* = 12mA
			3.22		V	I/O Drive strength* = 16mA
V _{ol}	Output Voltage Low		0.18	0.40	V	I _{ol} = +/-2mA

						I/O Drive strength* = 4mA
			0.12		V	I/O Drive strength* = 8mA
			0.08		V	I/O Drive strength* = 12mA
			0.07		V	I/O Drive strength* = 16mA
Vil	Input low Switching Threshold		-	0.80	V	LVTTL
Vih	Input High Switching Threshold	2.00	-		V	LVTTL
Vt	Switching Threshold		1.50		V	LVTTL
Vt-	Schmitt trigger negative going threshold voltage	0.80	1.10	-	V	
Vt+	Schmitt trigger positive going threshold voltage		1.60	2.00	V	
Rpu	Input pull-up resistance	40	75	190	KΩ	Vin = 0
Rpd	Input pull-down resistance	40	75	190	KΩ	Vin =VCCIO
Iin	Input Leakage Current	15	45	85	μA	Vin = 0
Ioz	Tri-state output leakage current		±10		μA	Vin = 5.5V or 0

Table 3.4 USBC-HS-UART-3.3V-3.3V-1800-SPR & USBC-HS-UART-5V-3.3V-1800-SPRI/O Pin Characteristics

* The I/O drive strength and slow slew-rate are configurable in the EEPROM.

The I/O pins are +3.3v cells, which are +5V tolerant

4 Cable PCB Circuit Schematic

The circuit schematics for the small internal electronic circuit board, utilising the FT232H, which is encapsulated into the USB Type C connector end of the cable, are shown in Figure 4-1 and Figure 4-2.

Customised versions of these cables are also available. Users interested in customised versions of these cables should contact Connective Peripherals Sales - sales@connectiveperipherals.com.

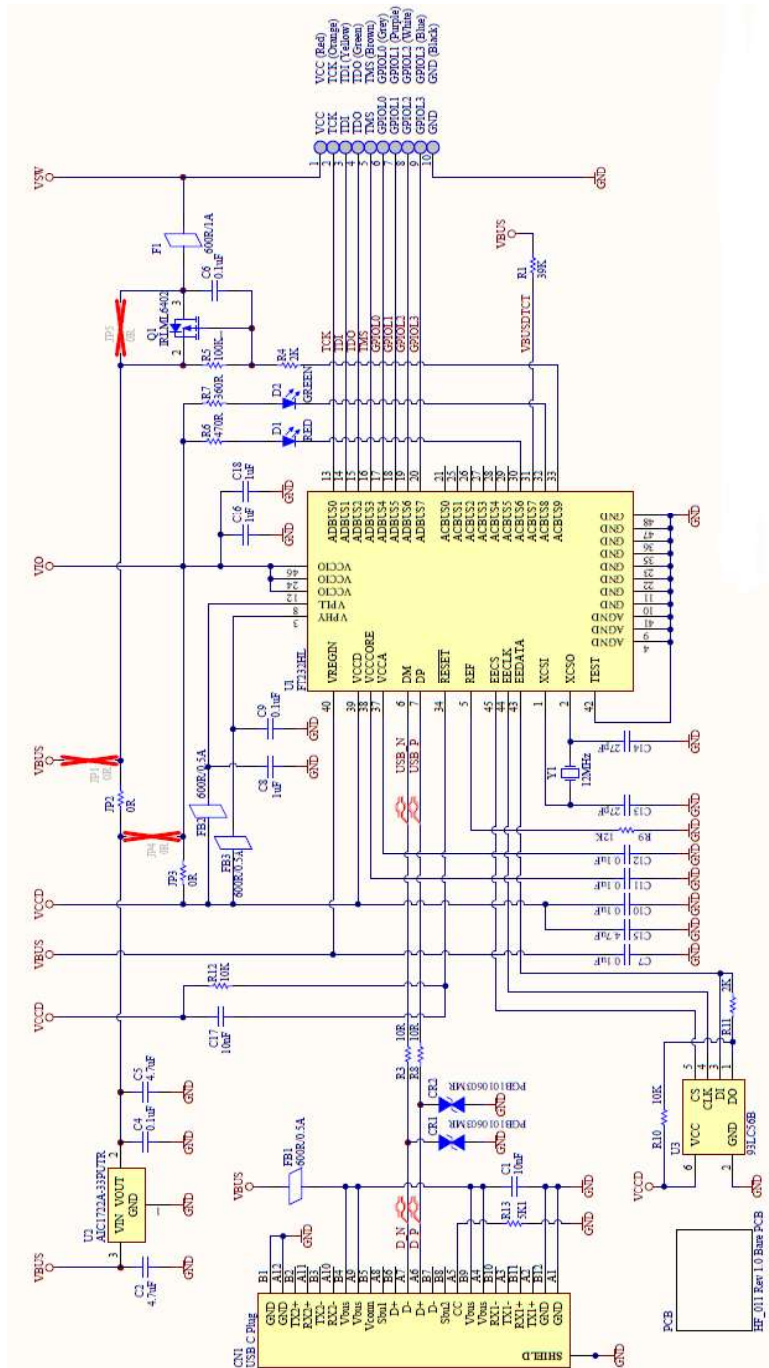

Figure 4-1 Circuit Schematic of PCB - USBC-HS-UART-3.3V-3.3V-1800-SPR

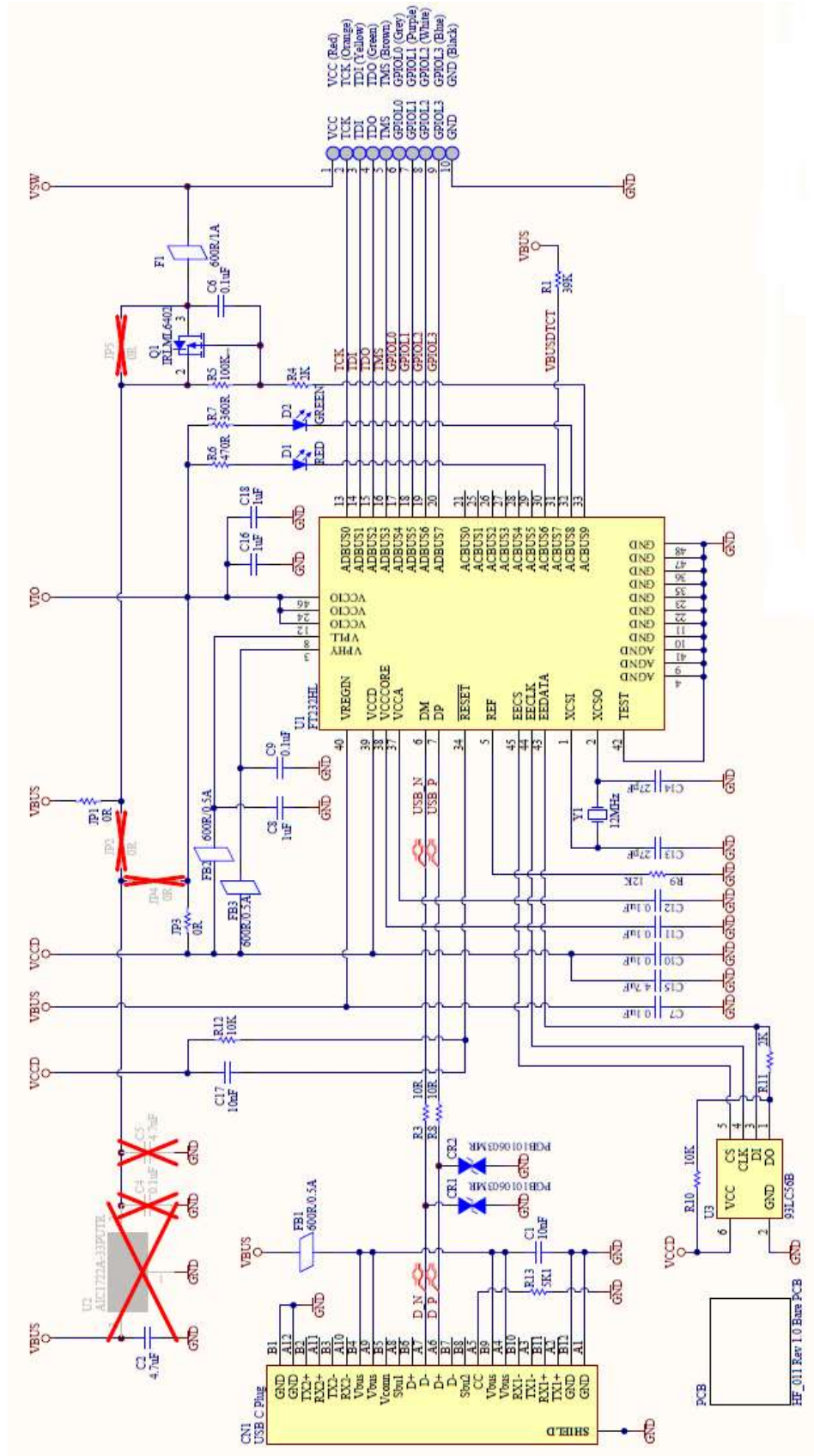

Figure 4-2 Circuit Schematic of PCB – USBC-HS-UART-5V-3.3V-1800-SPR

5 Contact Information

Global Headquarters – Singapore

Connective Peripherals Pte Ltd
1 Tai Seng Avenue, Tower A
#03-05
Singapore 536464

Tel: +65 67430980

E-Mail (Sales)	sales@connectiveperipherals.com
E-Mail (Support)	support@connectiveperipherals.com
Web Site URL	http://www.connectiveperipherals.com
Web Shop URL	http://www.connectiveperipherals.com

Appendix A - Cable EEPROM Configuration

Each USBC-HS-UART cable is controlled by the FTDI FT232H IC. This cable contains an EEPROM which contains the USB configuration descriptors for that device. When the cable is plugged into a PC or a USB reset is performed, the PC will read these descriptors. The default values stored into the internal EEPROM are defined in the following table.

Parameter	Value	Notes
USB Vendor ID (VID)	0403h	FTDI default VID (hex)
USB Product ID (PID)	6014h	FTDI default PID (hex)
Serial Number Enabled?	Yes	
Serial Number	See Note	A unique serial number is generated and programmed into the EEPROM during device final test.
Pull down I/O Pins in USB Suspend	Disabled	Enabling this option will make the device pull down on the UART interface lines when the power is shut off (PWREN# is high).
Manufacturer Name	FTDI	
Product Description	See note	Product description depends on the cable. The following lists the Product descriptions for each different cable. USBC-HS-UART-3.3V-3.3V-1800SPR USBC-HS-UART-5V-3.3V-1800-SPR
Max Bus Power Current	500mA	Includes power to operate the FT232H plus the cable output current.
Power Source	Bus Powered	
Device Type	FT232H	
USB Version	0200	Returns USB 2.0 device description to the host. Note: The device is a USB 2.0 Hi-Speed device (480Mb/s).
Remote Wake Up	Disabled	
High Current I/Os	Enabled	The device supports 4mA, 8mA, 12mA and 16mA drive strength settings. Default is 4mA.
Load VCP Driver	Enabled	Makes the device load the VCP driver interface for the device.

Default Internal EEPROM Configuration

The internal EEPROM in the cable can be re-programmed over USB using the utility program FT_PROG. Both can be downloaded from <https://www.ftdichip.com/>

Note that the EEPROM is supplied programmed ready to use for most applications. Changing the EEPROM settings is for advanced users only. Changing the settings can cause incorrect operation of the device. Before editing the VID or PID, note that this requires the user to have a driver with matching VID/PID in order to install the device before it can be used again. It is recommended to contact technical support if in doubt before making any changes.

Appendix B - References

Document References

[FT232H datasheet](#)

Acronyms & Abbreviations

Terms	Description
DLL	Dynamic Link Library
EHCI	Enhanced Host Controller Interface
EEPROM	Electrically Erasable Programmable Read Only Memory
FPGA	Field Programmable Gate Array
IC	Integrated Circuit
MCU	Microcontroller Unit
RoHS	Restriction of Hazardous Substance
SIL	Single In Line
OHCI	Open Host Controller Interface
PLD	Programmable Logic Device
TTL	Transistor-Transistor Logic
USB	Universal Serial Bus
UART	Universal Asynchronous Receiver/Transmitter
UHCI	Universal Host Controller Interface

Appendix C - List of Figures and Tables

List of Figures

Figure 1-1 Using the USBC-HS-UART	2
Figure 3-1 USBC-HS-UART Connections (numbers refer to pad numbers on the PCB)	7
Figure 3-2 USBC-HS-UART Mechanical Details (dimensions in mm)	8
Figure 4-1 Circuit Schematic of PCB - USBC-HS-UART-3.3V-3.3V-1800-SPR	11
Figure 4-2 Circuit Schematic of PCB - USBC-HS-UART-5V-3.3V-1800-SPR.....	12

List of Tables

Table 1.1 USBC-HS-UART Descriptions and Part Numbers.....	3
Table 3.1 USBC-HS-UART Signal Descriptions	9
Table 3.2 USBC-HS-UART-3.3V-3.3V-1800-SPR.....	9
Table 3.3 USBC-HS-UART-5V-3.3V-1800-SPR Power Supply Output Parameters	9
Table 3.4 USBC-HS-UART-3.3V-3.3V-1800-SPR & USBC-HS-UART-5V-3.3V-1800-SPR I/O Pin Characteristics	10

Appendix D – Revision History

Revision	Changes	Date
Version 1.0	Initial Release	29-07-2020
Version 1.1	Updated Fig 4.1 & Fig 4.2 to new schematics Updated the Part Number & Device Description Updated Default Internal EEPROM Configurations table	07-10-2020
Version 1.2	Added driver install section and other minor updates	30-01-2023
Version 1.3	Updated Address	23-05-2024