



## **USBC-FS-UART-5V-5V-1800-WE**

### **Datasheet**

**Document Reference No.: CP\_000062**

**Version 1.3**

**Connective Peripherals Pte Ltd**

**1 Tai Seng Avenue, Tower A, #03-05, Singapore 536464**

**Tel.: +65 67430980**

E-Mail (Support): [support@connectiveperipherals.com](mailto:support@connectiveperipherals.com) Web: [www.connectiveperipherals.com/products](http://www.connectiveperipherals.com/products)

Neither the whole nor any part of the information contained in, or the product described in this manual, may be adapted or reproduced in any material or electronic form without the prior written consent of the copyright holder. This product and its documentation are supplied on an as-is basis and no warranty as to their suitability for any particular purpose is either made or implied. Connective Peripherals Pte Ltd will not accept any claim for damages howsoever arising as a result of use or failure of this product. Your statutory rights are not affected. This product or any variant of it is not intended for use in any medical appliance, device or system in which the failure of the product might reasonably be expected to result in personal injury. This document provides preliminary information that may be subject to change without notice. No freedom to use patents or other intellectual property rights is implied by the publication of this document. Connective Peripherals Pte Ltd, 1 Tai Seng Avenue, Tower A, #03-05, Singapore 536464. Registered Number: 201617872E

**Copyright © Connective Peripherals Pte Ltd**

## 1 Introduction

The **USBC-FS-UART-5V-5V-1800-WE** is a USB Type C to TTL serial UART converter cable incorporating the FT232R USB to Serial UART interface IC device which handles all the USB signalling and protocols. The cables provide a fast, simple way to connect devices with a logic level serial interface to USB Type C.

Each USBC-FS-UART-5V-5V-1800-WE contains a small internal electronic circuit board, utilising the [FT232R](#), which is encapsulated into the USB Type C connector end of the cable. Refer to the [FT232R](#) datasheet more details. The other end of the cable is wire ended. The cable can be used for TTL or interface logic.

Cable are FCC, CE, UKCA and RoHS compliant at TTL levels of + 5V.

The USB Type C side of the cable is USB powered and is USB 2.0 full speed compatible. Each cable is 1.8m long and supports a data transfer rate up to 3 Mbaud. Each cable supports the FTDIChip-ID™, with a unique USB serial number programmed into the FT232R. This feature can be used to create a security or password protected file transfer access using the cable. Further information and examples on this feature are available at [FTDIChip-ID Projects](#).

The USBC-FS-UART-5V-5V-1800-WE requires USB drivers, available free from <http://www.connectiveperipherals.com>, which are used to make the FT232R in the cable appear as a virtual COM port (VCP). This allows the user to communicate with the USB Type C interface via a standard PC serial emulation port (for example TTY). Another USB driver, the D2XX driver, can also be used with application software to directly access the FT232R on the cable though a DLL. This is illustrated in Figure 1-1.

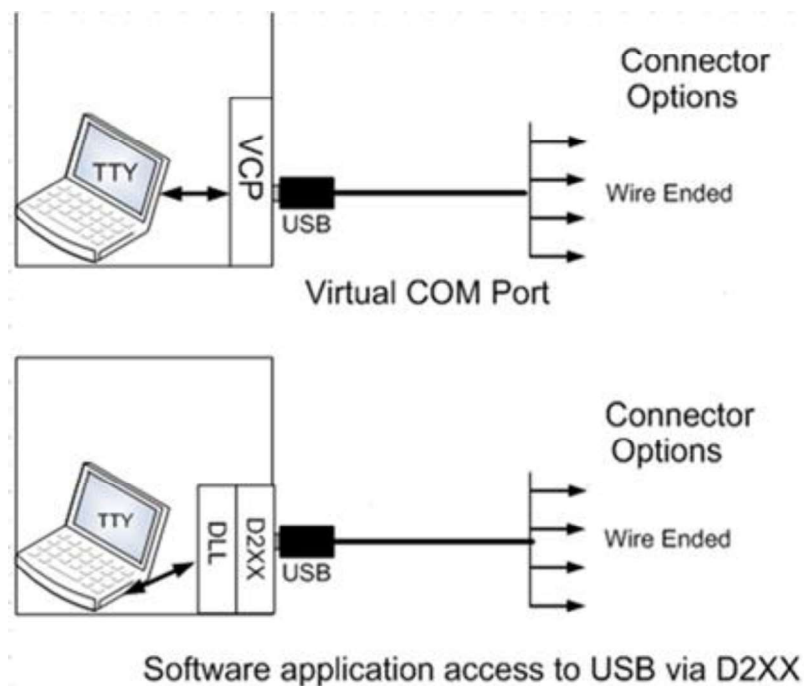

**Figure 1-1 - Using the USBC-FS-UART-5V-5V-1800-WE**

## 1.1 Part Numbers

The following Table 1.1 gives details of USBC-FS-UART-5V-5V-1800-WE part numbers.

Part Number	Description	End Connector*	Cable details
USBC-FS-UART-5V-5V-1800-WE	USB Type C to UART cable with up to 5V TTL level UART signals. Maximum output of 450mA on VCC (see <b>Note 1</b> )	Wire Ended (no connector)	6 core, UL2464 26 AWG, diam=4.8mm, Black

**Table 1.1 USBC-FS-UART-5V-5V-1800-WE Descriptions and Part Numbers**

**Note 1:** The VCC power output signal (RED wire) is 5.0V. The source of 5.0V is the USB Type C VBUS input, which is switched onto the power output signal (enabled when the FT232R is enumerated and not in suspend)

CP supports customised end connector designs. For more information, please contact your local CP sales office (see section **6** for contact details).

## 1.2 Certifications

The USBC-FS-UART-5V-5V-1800-WE is fully RoHS compliant and FCC, CE and UKCA approved.



## **Table of Contents**

<b>1</b>	<b>Introduction</b>	<b>2</b>
1.1	Part Numbers	3
1.2	Certifications	3
<b>2</b>	<b>Typical Applications</b>	<b>5</b>
2.1	Driver Support	5
2.2	Driver Installation	5
2.3	Features	6
<b>3</b>	<b>FT232R features applicable to USBC-FS-UART-5V-5V-1800-WE</b>	<b>7</b>
<b>4</b>	<b>USBC-FS-UART-5V-5V-1800-WE connection &amp; mechanical details</b>	<b>8</b>
4.1	USBC-FS-UART-5V-5V-1800-WE Generic Cables Signal Desc.	8
4.2	USBC-FS-UART-5V-5V-1800-WE Electrical Parameters	9
<b>5</b>	<b>Cable PCB Circuit Schematic</b>	<b>10</b>
<b>6</b>	<b>Contact Information</b>	<b>11</b>
	<b>Appendix A - Cable EEPROM Configuration</b>	<b>16</b>
	<b>Appendix B - References</b>	<b>17</b>
	Document References	17
	Acronyms and Abbreviations	17
	<b>Appendix C - List of Figures and Tables</b>	<b>18</b>
	List of Figures	18
	List of Tables	18
	<b>Appendix D – Revision History</b>	<b>19</b>

## 2 Typical Applications

- USB to Serial TTL Level Converter
- Upgrading Legacy Peripherals to USB
- Interface Microcontroller UART or I/O to USB
- Interface FPGA / PLD to USB
- USB Instrumentation PC interface
- USB Industrial Control
- USB Software / Hardware Encryption Dongles
- Replace MAX232 type level shifters allowing for direct connection of products with logic level signals to the PC via USB

### 2.1 Driver Support

#### Royalty free VIRTUAL COM PORT

##### (VCP) DRIVERS for...

- Windows 11, 10, 8.x, 7
- Windows XP (legacy)
- Windows CE 4.2, 5.0 and 6.0 (Legacy)
- macOS 10.9 and above
- Linux 2.4 and greater

#### Royalty free D2XX *Direct* Drivers

##### (USB Drivers + DLL S/W Interface)

- Windows 11, 10, 8.x, 7
- Windows XP (legacy)
- Windows CE 4.2, 5.0 and 6.0 (Legacy)
- macOS 10.9 and above
- Linux 2.4 and greater

The drivers listed above are all available to download for free from <https://connectiveperipherals.com>. Various legacy and 3rd Party Drivers are also available for other operating systems. Refer to <https://connectiveperipherals.com> and [www.ftdichip.com](http://www.ftdichip.com) for details.

### 2.2 Driver Installation

For driver installation, please refer to the **Connective Peripherals USB to Serial Converters Driver Installation Guide (CP\_000084)** which is available from [www.connectiveperipherals.com](http://www.connectiveperipherals.com).

## 2.3 Features

- USBC-FS-UART-5V-5V-1800-WE provides a USB Type C to TTL Serial interface.
- On board FT232R provides single chip USB to asynchronous serial data transfer interface.
- Entire USB protocol handled by the electronics in the cable USB Type C.
- Connect directly to a microcontroller UART or I/O pins.
- UART interface support for 7 or 8 data bits, 1 or 2 stop bits and odd / even / mark / space / no parity.
- Fully assisted hardware (RTS#/CTS#) or X-On / X-Off software handshaking.
- Data transfer rates from 300 baud to 3 Mbaud at TTL levels.
- Internal EEPROM with user writeable area.
- 5.0V safe TTL inputs makes the USBC-FS-UART-5V-5V-1800-WE easy to interface to 5.0V MCU's.
- FTDI's royalty-free VCP allow for communication as a standard emulated COM port and D2XX 'direct' drivers provide DLL application programming interface.
- Support for FT232R FTDIChip-ID™ feature for improved security.
- Voltage output power allows external logic to be powered from the USB Type C port.
- 6 way outputs provide Tx, Rx, RTS#, CTS#, VCC and GND.
- Low USB bandwidth consumption.
- UHCI / OHCI / EHCI host controller compatible.
- USB 2.0 (12Mb/s) Full Speed compatible.
- -40°C to +85°C operating temperature range.
- Cable length is 1.80m (6 feet).
- FCC, CE and UKCA compliant.
- Custom versions also available (subject to MOQ).

### 3 FT232R features applicable to USBC-FS-UART-5V-5V-1800-WE

The USBC-FS-UART-5V-5V-1800-WE use the FT232R USB to serial IC device. This section summarises the key features of the FT232R which apply to the USBC-FS-UART-5V-5V-1800-WE USB to serial TTL converter cable. For further details, and a full features and enhancements description refer to the [FT232R](#) datasheet.

**Internal EEPROM.** The internal EEPROM in each cable is used to store USB Vendor ID (VID), Product ID (PID), device serial number, product description string and various other USB configuration descriptors. Each cable is supplied with the internal EEPROM pre-programmed as described in [Appendix A](#). A user area in the internal EEPROM is available to system designers to allow storing additional data. The internal EEPROM descriptors can be programmed in circuit, over USB without any additional voltage requirement. It can be programmed using the FTDI utility software called FT\_Prog, which can be downloaded <https://www.ftdichip.com/Support/Utilities.htm>. Note that the user area is not modifiable using FT\_Prog.

**Lower Operating and Suspend Current.** The FT232R has a low 15mA operating supply current and a very low USB suspend current of approximately 70µA. (Note that during suspend mode, the current drawn by application should not exceed 2.5mA to remain USB compliant).

**Low USB Bandwidth Consumption.** The USB interface of the FT232R, and therefore the USBC-FS-UART-5V-5V-1800-WE, has been designed to use as little as possible of the total USB bandwidth available from the USB host controller.

**High Output Drive Option.** The UART interface I/O pins on the USBC-FS-UART-5V-5V-1800-WE (RXD, TXD, RTS#, and CTS#) can be configured to use the FT232R's high output drive option. This option allows the FT232R I/O pins to drive up to three times the standard signal drive level. This allows multiple devices to be driven, or devices that require greater signal drive strength to be interfaced to the cable. This option is enabled in the internal EEPROM.

**UART Pin Signal Inversion.** The sense of each of the eight UART signals can be individually inverted by configuring options in the internal EEPROM. For example CTS# (active low) can be changed to CTS (active high), or TXD can be changed to TXD#.

**FTDICHip-ID™.** The FT232R includes the FTDICHip-ID™ security dongle feature. This FTDICHip-ID™ feature allows a unique number to be burnt into each cable during manufacture. This number cannot be reprogrammed. This number is only readable over USB can be used to form the basis of a security dongle which can be used to protect any customer application software being copied. This allows the possibility of using the USBC-FS-UART-5V-5V-1800-WE as a dongle for software licensing. Further to this, a renewable license scheme can be implemented based on the FTDICHip-ID™ number when encrypted with other information. This encrypted number can be stored in the user area of the FT232R internal EEPROM, and can be decrypted, then compared with the protected FTDICHip-ID™ to verify that a license is valid. Refer to [AN232R-01 FTDICHip-ID for the FT232R and FT245R](#) for more details.

**Improved EMI Performance.** The USBC-FS-UART-5V-5V-1800-WE is FCC, CE and UKCA certified.

**Extended Operating Temperature Range** - The USBC-FS-UART-5V-5V-1800-WE is capable of operating over an extended temperature range of -40° to +85° C thus allowing them to be used in automotive or industrial applications.

## 4 USBC-FS-UART-5V-5V-1800-WE connection & mechanical details

The following Figure 4-1 shows the cable signals and the wire colours for these signals on the USBC-FS-UART-5V-5V-1800-WE.

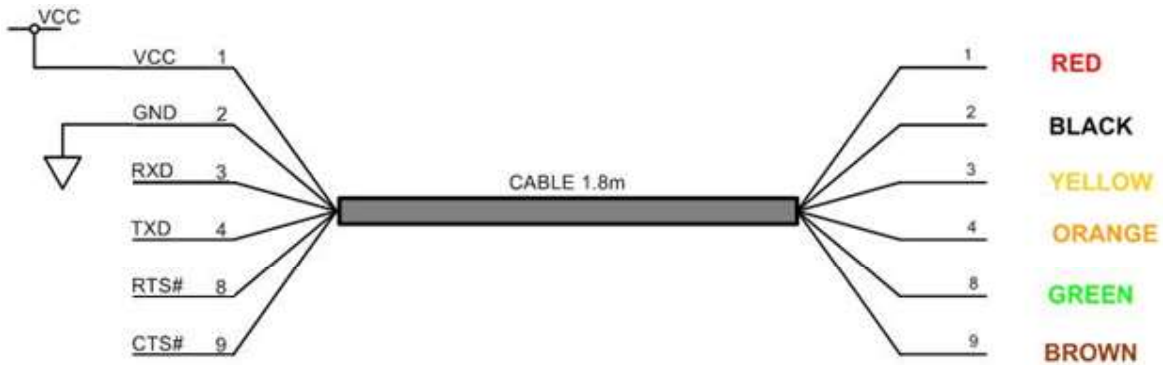

**Figure 4-1 USBC-FS-UART-5V-5V-1800-WE Connections (nos. refer to pad numbers on the PCB)**

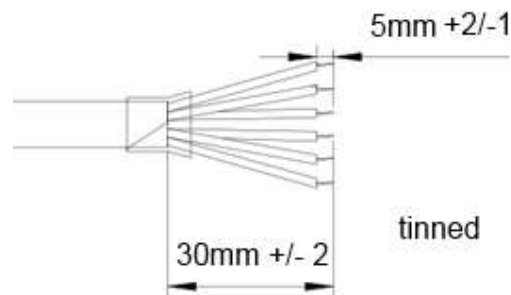

**Figure 4-2 USBC-FS-UART-5V-5V-1800-WE Mechanical Details (dimensions in mm)**

### 4.1 USBC-FS-UART-5V-5V-1800-WE Generic Cables Signal Desc.

Colour	Name	Type	Description
Black	GND	GND	Device ground supply pin.
Brown	CTS#	Input	Clear to Send Control input / Handshake signal.
Red	VCC	Output	Power Supply Output
Orange	TXD	Output	Transmit Asynchronous Data output.
Yellow	RXD	Input	Receive Asynchronous Data input.
Green	RTS#	Output	Request To Send Control Output / Handshake signal.

**Table 4.1 USBC-FS-UART-5V-5V-1800-WE Generic Cable Signal Descriptions**



## 4.2 USBC-FS-UART-5V-5V-1800-WE Electrical Parameters

Parameter	Description	Minimum	Typical	Maximum	Units	Conditions
VCC	Output Power Voltage	4.25	5.0	5.25	V	
IO	Supply Current	-	450		mA	Must be less than 2.5mA during suspend.
T	Operating Temperature Range	-40		+85	oC	

**Table 4.2 USBC-FS-UART-5V-5V-1800-WE I/O Operating Parameters**

Parameter	Description	Minimum	Typical	Maximum	Units	Conditions
Voh	Output Voltage High	3.2	4.1	4.9	V	I source = 6mA
Vol	Output Voltage Low	0.3	0.4	0.6	V	I sink = 6mA
Vin	Input Switching Threshold	1.0	1.2	1.5	V	
VHys	Input Switching Hysteresis	20	25	30	mV	

**Table 4.3 USBC-FS-UART-5V-5V-1800-WE I/O Pin Characteristics**



## 6 Contact Information

### Global Headquarters – Singapore

Connective Peripherals Pte Ltd  
1 Tai Seng Avenue, Tower A  
#03-05  
Singapore 536464

Tel: +65 67430980

E-Mail (Sales)	<a href="mailto:sales@connectiveperipherals.com">sales@connectiveperipherals.com</a>
E-Mail (Support)	<a href="mailto:support@connectiveperipherals.com">support@connectiveperipherals.com</a>
Web Site URL	<a href="http://www.connectiveperipherals.com">http://www.connectiveperipherals.com</a>
Web Shop URL	<a href="http://www.connectiveperipherals.com">http://www.connectiveperipherals.com</a>

## Appendix A - Cable EEPROM Configuration

Each USBC-FS-UART-5V-5V-1800-WE is controlled by the FT232R IC. This FT232R device contains an EEPROM which contains the USB configuration descriptors for that device. When the cable is plugged into a PC or a USB reset is performed, the PC will read these descriptors. The default values stored into the internal EEPROM are defined in the following table.

Parameter	Value	Notes
USB Vendor ID (VID)	0403h	FTDI default VID (hex)
USB Product UD (PID)	6001h	FTDI default PID (hex)
Serial Number Enabled?	Yes	
Serial Number	See Note	A unique serial number is generated and programmed into the EEPROM during device final test.
Pull down I/O Pins in USB Suspend	Disabled	Enabling this option will make the device pull down on the UART interface lines when the power is shut off (PWREN# is high).
Manufacturer Name	FTDI	
Product Description	See note	USBC-FS-UART-5V-5V-1800-WE
Max Bus Power Current	90mA	
Power Source	Bus Powered	
Device Type	FT232R	
USB Version	0200	Returns USB 2.0 device description to the host. Note: The device is a USB 2.0 Full Speed device (12Mb/s).
Remote Wake Up	Disabled	
High Current I/Os	Enabled	The device supports 4mA, 8mA, 12mA and 16mA drive strength settings. Default is 4mA.
Load VCP Driver	Enabled	Makes the device load the VCP driver interface for the device.
Invert TXD	Disabled	Signal on this pin becomes TXD# if enable.
Invert RXD	Disabled	Signal on this pin becomes RXD# if enable.
Invert RTS#	Disabled	Signal on this pin becomes RTS if enable.
Invert CTS#	Disabled	Signal on this pin becomes CTS if enable.

## Appendix B - References

### Document References

[DS\\_FT232R](#)

[AN232R-01 FTDIChip-ID for the FT232R and FT245R](#)

### Acronyms and Abbreviations

Terms	Description
DLL	Dynamic Link Library
EEPROM	Electrically Erasable Programmable Read Only Memory
EHCI	Enhanced Host Controller Interface
FCC	Federal Communications Commission
FPGA	Field Programmable Gate Array
I/O	Input Output
OHCI	Open Host Controller Interface
PC	Personal Computer
PLD	Programmable Logic Device
TTL	Transistor-Transistor Logic
UART	Universal Asynchronous Receiver Transmitter
UHCI	Universal Host Controller Interface
USB	Universal Serial Bus
VCP	Virtual COM Port

## Appendix C - List of Figures and Tables

### List of Figures

Figure 1-1 - Using the USBC-FS-UART-5V-5V-1800-WE.....	2
Figure 4-1 USBC-FS-UART-5V-5V-1800-WE Connections (nos. refer to pad numbers on the PCB).....	8
Figure 4-2 USBC-FS-UART-5V-5V-1800-WE Mechanical Details (dimensions in mm) .....	8
Figure 5-1 Circuit Schematic of PCB used in the TTL to USBC Serial Converter Cable.....	10

### List of Tables

Table 1.1 USBC-FS-UART-5V-5V-1800-WE Descriptions and Part Numbers .....	3
Table 4.1 USBC-FS-UART-5V-5V-1800-WE Generic Cable Signal Descriptions.....	8
Table 4.2 USBC-FS-UART-5V-5V-1800-WE I/O Operating Parameters .....	9
Table 4.3 USBC-FS-UART-5V-5V-1800-WE I/O Pin Characteristics .....	9

## Appendix D – Revision History

Revision	Changes	Date
Version 1.0	Initial Release	29-07-2020
Version 1.1	Updated the Part Number & Device Description Updated the Default Internal EEPROM Configuration table	07-10-2020
Version 1.2	Added driver install section and other minor updates	30-01-2023
Version 1.3	Updated Address	23-05-2024