



Connective Peripherals Pte Ltd

**USB2-H-9002-M Hi-Speed USB to 2-Port
RS232/RS485 Adaptor**

Data Sheet

Document Reference No.: CP_000030

Version 1.2

Issue Date: 21-10-2022

The USB2-H-9002-M provides a simple method of adapting legacy serial devices with RS232 and RS485 interfaces to modern USB ports by incorporating the FTDI FT2232H Hi-Speed USB bridge chip.

The adaptor, which is contained within a metal case, can be powered over USB or from an external power supply. It can also supply an output of +5VDC at up to 250mA (total across all ports) on the 5mm terminal block connectors. Indicator LEDs provide functional status.

Connective Peripherals Pte Ltd
178 Paya Lebar Road, #07-03 Singapore 409030
Tel.: +65 67430980 Fax: +65 68416071

E-Mail (Support): support@connectiveperipherals.com Web: www.connectiveperipherals.com/products

Neither the whole nor any part of the information contained in, or the product described in this manual, may be adapted, or reproduced in any material or electronic form without the prior written consent of the copyright holder. This product and its documentation are supplied on an as-is basis and no warranty as to their suitability for any particular purpose is either made or implied. Connective Peripherals Pte Ltd will not accept any claim for damages howsoever arising as a result of use or failure of this product. Your statutory rights are not affected. This product or any variant of it is not intended for use in any medical appliance, device, or system in which the failure of the product might reasonably be expected to result in personal injury. This document provides preliminary information that may be subject to change without notice. No freedom to use patents or other intellectual property rights is implied by the publication of this document. Connective Peripherals Pte Ltd, 178 Paya Lebar Road, #07-03 Singapore 409030. Registered Number: 201617872E

Table of Contents

1	Introduction	4
1.1	Functional Description	4
1.2	LED Description	5
1.3	Block Diagram	5
1.3.1	Block description	5
1.4	Features	6
1.5	Performance Figures	7
1.6	Ordering Information	7
2	Installation	8
2.1	Hardware Configuration	8
2.1.1	Mounting	9
2.2	Driver Installation	9
3	Connections	10
3.1	External Connectors	10
3.1.1	USB	10
3.1.2	RS232 Connections	10
3.1.3	RS485 Connections	10
4	Electrical details	11
4.1	USB	11
4.2	PSU Input	11
4.3	RS232	11
4.4	RS485	11
4.5	Power Output	12
5	Mechanical Details	13
6	Physical Environment Details	15
6.1	Storage Temperature	15
6.2	Operating Temperature	15
7	Environmental Approvals & Declarations	16
7.1	EMI Compatibility	16
7.2	Safety	16

7.3	Environmental.....	16
7.4	Reliability.....	16
7.5	Import / Export Information	17
8	Troubleshooting	18
8.1	Hardware.....	18
8.2	Device Driver	18
8.3	Technical Support	19
9	Contact Information.....	20
	Appendix A – List of Figures and Tables.....	21
	Appendix B – Revision History	22

1 Introduction

1.1 Functional Description

The USB2-H-9002-M adaptor is a USB to dual interface RS232 or RS485 level serial UART adaptor incorporating FTDI's FT2232H Hi-Speed USB2.0 (480Mb/s) to dual serial UART interface IC device. The FT2232H manages all the USB signaling and protocols. The adaptor is housed in a metal enclosure and provides a fast, straightforward way to connect devices with an RS232 or RS485 interface to USB.

The integrated electronics of the USB2-H-9002-M utilise the FTDI FT2232H and include RS485 level shifters and RS232 level shifters plus TXD/RXD LEDs to provide a visual indication of data traffic through the adaptor. Selection of RS232 or RS485 signalling is made using DIL switches on the front of the adaptor. Each of the dual channels can be independently configured as either RS232 or RS485.



Figure 1.1 USB2-H-9002-M

Flexible mounting allows the USB2-H-9002-M to be used in a variety of applications, from a portable adaptor to accompany a laptop to permanent installations in industrial, commercial, and retail locations.

The metal enclosure incorporates a standard USB-B client connector for connection to an upstream host or hub port. RS232 and RS485-level signals are available on two 5mm terminal block connectors. The maximum RS485-level data rate is 8Mbps and the maximum RS232-level data rate is 1Mbps.

The adaptor can be independently powered using an external +5V DC (1A) power supply which connects via a 2.1mm jack socket. It can also be powered from the USB interface if required.

The USB2-H-9002-M adaptor requires USB device drivers, available free from <https://connectiveperipherals.com>. These are used to make the USB2-H-9002-M appear as a Virtual COM Port (VCP). This allows existing serial communications software, such as HyperTerminal, to exchange data through the USB2-H-9002-M to a legacy RS485 or RS232 peripheral device.

1.2 LED Description

The USB2-H-9002-M uses 5 LEDs to indicate a valid link as well as data traffic according to the following table:

LED Color	Function	Description	Quantity
Yellow	PWR	ON when USB2-H-9002-M is powered, configured and ready for use.	1
Red	TxD Activity	Flashes when the data is transmitted from the USB2-H-9002-M to the attached RS232 or RS485 device. One LED for each UART channel	2
Green	RxD Activity	Flashes when the data is transmitted from the attached RS232 or RS485 device to the USB2-H-9002-M. One for each UART channel.	2

Table 1.1 – LED Description

1.3 Block Diagram

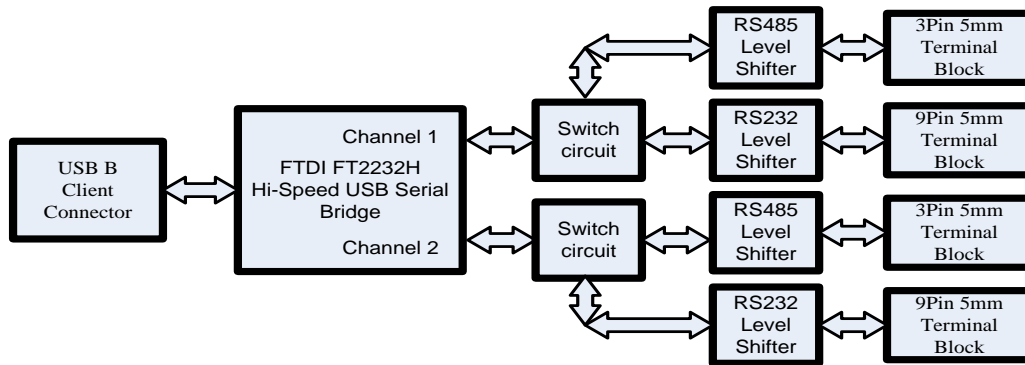

Figure 1.2 USB2-H-9002-M Block Diagram

1.3.1 Block description

USB B Client Connector

This connector provides the interface for connection to a USB Host or Hub port. A standard "A to B" cable is provided, though one of a different length may also be used. The maximum cable length is 5 meters, according to the USB 2.0 specification.

FTDI FT2232H

[FT2232H](#) Hi-Speed USB2.0 (480Mb/s) is a dual serial UART interface IC device. Operating system device drivers are required in order to work with the FT2232H to provide the Virtual COM Port serial functionality.

Dual RS485 Level Shifter

The RS485 level shifter converts the signals provided by the FT2232H into the voltage levels required by RS485 devices.

RS485 connectors

Two 3 pin 5mm terminal block connectors provide the connection to RS485 peripheral devices. These are CN5 for channel 1 and CN9 for channel 2 (The RS485 and RS232 share the same GND pin which is the middle pin of these connectors).

Dual RS232 Level Shifter

The RS232 level shifter converts the signals provided by the FT2232H into the voltage levels required by RS232 devices.

RS232 Connectors

Two 8 pin 5mm terminal block connectors provide the connection to RS232 peripherals devices. These are made up from 3 connectors CN2, 3 and 4 for channel 1 and CN6, 7 and 8 for channel 2. The RS232 and RS485 share the same GND pin.

Switching circuit

The switching circuit configures which mode, RS232 or RS485, is set for each channel. The switches SW1 and SW2 also enable or disable other functions (RS485 echo, RS485 termination, 5Vout).

1.4 Features

- Adds dual RS-232 or RS-485 serial ports by connecting to a USB 2.0 Hi-Speed interface.
- Easy plug & play installation and RS-232/RS-485 device connection
- USB2.0 Hi-Speed (480Mbps) interface (works with USB 1.1, 2.0 and 3.0 Host and Hub ports)
- Industry Standard FTDI chip set & device drivers for maximum compatibility
- Microsoft Windows® WHQL-certified drivers (Windows 7 - Windows 11)
- Legacy drivers also available for older Windows versions back to XP, and Windows CE
- MacOS and Linux device drivers
- Installs as a standard Windows COM port
- COM port number can be changed to any available COM port number, to support HyperTerminal, or any other serial communications software application running in Windows
- RS-485 Echo and non-Echo mode selection
- RS-485 Termination ON and Termination OFF mode selection.
- FIFO: 4k byte transmit buffer, 4k byte receive buffer
- RS-485 data signals: Data+, Data-, GND
- RS-232 data signals: TxD, RxD, RTS, CTS, DTR, DSR, DCD, RI, GND
- Selectable +5VDC Power source from USB port or external power adaptor.
- +5VDC output at 250mA. (total on 2 ports)
- Set in RS232 mode, the serial port operates up to 1Mbps
- Set in RS485 mode, the serial port operates up to 8Mbps
- Serial Communication Parameters
 - Parity: None, Even, Odd
 - Data bits: 7, 8
 - Flow control: X-ON/X-OFF, None (set in RS485 mode)
 - Flow control: RTS/CTS, DTR/DSR, X-ON/X-OFF, None (set in RS232 mode)
- LEDs indicate RxD, TxD and power for monitoring port status.
- Operating temperature of -40°C to +85°C
- USB cable of 0.9-meter length included
- FCC, UKCA and CE approved.

1.5 Performance Figures

Parameter	Performance
USB Interface	480Mbps USB 2.0 Hi-Speed
RS485 Interface	Standard Windows baud rates (300bps to 921.6Kbps) Custom baud rates (300bps to 8Mbps) through baud rate aliasing. See FTDI Application Note AN_120: Aliasing Baud Rates
RS232 Interface	Standard Windows baud rates (300bps to 921.6Kbps) Custom baud rates (300bps to 1Mbps) through baud rate aliasing. See FTDI Application Note: AN_120: Aliasing Baud Rates

Table 1.2 – Performance Figures

1.6 Ordering Information

Part Number	Description
USB2-H-9002-M	Hi-Speed USB to 2-Port RS232/RS485 adaptor with metal case

Table 1.3 – Ordering Information

2 Installation

2.1 Hardware Configuration

The USB2-H-9002-M supports 2 serial channels. Each channel can be independently set as either RS232 or RS485. Channel configuration is done using switches SW1 and SW2. Various jumpers also allow power supply source and pull-up/pull-down termination resistors.

Switch SW1 and SW2 Settings

The default SW1 switch settings enable RS485 mode. This can be changed as shown in the following table:

SW1 Position Channel 1 configuration	SW2 Position Channel 2 configuration	Open (off)	Closed (on)
1	1	RS232 mode	RS485 mode
2	2	RS485 Echo enabled	RS485 Echo disabled
3	3	120R Termination resistor enabled	120R Termination resistor disabled
4	4	5V Out Disable	5V Out Enable

Table 2.1 – Switch Setting Configuration of the USB2-H-9002-M

The following gives a brief description of the SW1 and SW2 switches.

Modes:

The USB2-H-9002-M can be configured as either an RS232 or RS485 serial interface.

Echo:

When the serial interface is set to RS485, then echo can be enabled or disabled.

Termination:

The USB2-H-9002-M has a 120Ω termination resistor for each channel which can be switched in or out of the circuit when the channel is used in RS485 mode.

5V Out:

The RI pin of each channel can alternatively be used to output a +5V supply if the RI function is not required. This +5V supply is available after the USB2-H-9002-M is fully enumerated, and device drivers are loaded, and can be enabled/disabled on each port independently. To enable the output of +5V, set the 5V Out Enable DIP switch for the associated port to ON and ensure that the corresponding jumper for that channel inside the unit is also populated (see Table 2.2)

Jumper Settings

There are various jumpers on the adaptor PCB. These can be used to select the functions described in the following table:

Channel	Jumper	Connections made	Function
1 and 2	JP1	1-2	Power supplied from USB Host 5V
		2-3 (default)	Power supplied from +5V power jack input.
1	JP2	connected (default)	Connects the +5V output onto the channel 1 RI output pin if the +5V has been enabled. Requires position 4 of SW1 closed.
		Not connected	Disconnects the +5V output on the channel 1 RI output pin
2	JP3	connected (default)	Connects the +5V output onto the channel 2 RI output pin if the +5V has been enabled. Requires position 4 of SW2 closed.
		Not connected	Disconnects the +5V output on the channel 2 RI output pin

Table 2.2 –Jumper Selection of USB2-H-9002-M

2.1.1 Mounting

The USB2-H-9002-M can be wall mounted using the mechanical metal brackets. This is shown in the following figure

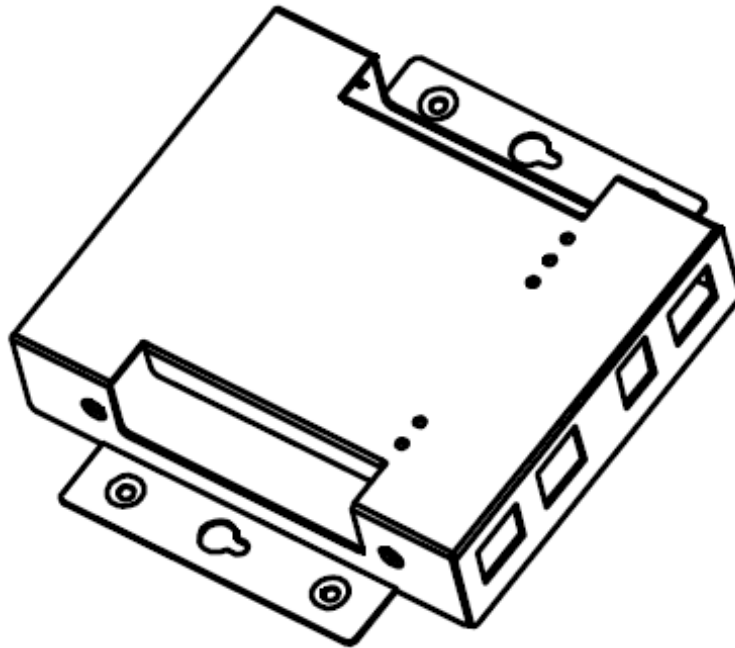

Figure 2.1 – USB2-H-9002-M Brackets

2.2 Driver Installation

For driver installation, please refer to the **Connective Peripherals USB to Serial Converters Driver Installation Guide (CP_000084)** which is available from www.connectiveperipherals.com.

3 Connections

3.1 External Connectors

3.1.1 USB

The USB2-H-9002-M is a downstream USB 2.0 Device and is connected via a standard USB-B client connector to an upstream USB Host or Hub.

Pin Number	Pin Type	Description
1	Power	VBUS – USB Power provided from upstream USB Host or Hub
2	Bidirectional	D- = USB data signal, negative polarity
3	Bidirectional	D+ = USB data signal, positive polarity
4	Ground	GND = USB signal ground
Shield	Case Ground	Drain = typically connected to the host PC case

Table 3.1 – USB B Receptacle Pin-Out

3.1.2 RS232 Connections

Each RS232 port is connected through a 5mm terminal block connector. This is shown in the following table:

Terminal Block Pin Number (Channel 1 and Channel 2)	Pin Type	Description
1	Output	TXD = Transmit Data
2	Input	RXD = Receive Data
3	Output	RTS = Request To Send
4	Input	CTS = Clear To Send
5	Output	DTR = Data Terminal Ready
6	Input	DSR = Data Set Ready
7	Input	DCD = Data Carrier Detect
8	Input or PWR output	RI = Ring Indicator or +5V DC output
9	Ground	GND = RS232 signal ground

Table 3.2 – Connections required for RS232 serial interface

In addition, RI Pin can provide +5VDC to an external device with a maximum current draw of 250mA (total across both ports) once the USB2-H-9002-M has been enumerated by the system.

3.1.3 RS485 Connections

Each RS485 port is connected through a 5mm terminal block connector. This is shown in the following table:

Terminal Block Pin Number (Channel 1 and Channel 2)	Pin Type	Description
8	Input or PWR output	Can be configured as PWR = +5V DC output depending on SW settings and jumper settings
9	GND	GND
10	Input/Output	DATA+
11	Input/Output	DATA-

Table 3.3 – Connector of RS485 Pin-Out

4 Electrical details

4.1 USB

Parameter	Description	Minimum	Typical	Maximum	Units	Conditions
USB_VCC	Input Power Voltage*	4.25	5.0*	5.25	V	*Present when USB cable is attached, and USB Host or Hub powered.
I _{cc}	USB current***		100	150	mA	***Does not include power supplied to external device when RI/PWR pin is configured for +5V output

Table 4.1 – USB Electrical Details

4.2 PSU Input

Parameter	Description	Minimum	Typical	Maximum	Units	Conditions
V _{in}	Power supply input		5.0		V	Maximum of 1A

Table 4.2 – PSU Input Details

4.3 RS232

Parameter	Description	Minimum	Typical	Maximum	Units	Conditions
V _{trans}	Transmitter output voltage swing	± 5			V	RL = 3KΩ
V _{rec}	Receiver input voltage range	±2.4		±25	V	Input resistance = 3KΩ to 7KΩ
	ESD HBM		±15		KV	RS-232 Inputs and Outputs

Table 4.3 – RS232 Electrical Details

4.4 RS485

Parameter	Description	Minimum	Typical	Maximum	Units	Conditions
Receiver Input						
VCM	Common-mode input voltage range	-7	+12		V	
IN	Input Current			1.0	mA	V _{IN} = +12V
				-0.8		V _{IN} = -7V
VTH	Differential Threshold Voltage, VTH	-0.2		+0.2	V	
VIHYS	Input Hysteresis		20		mV	
RIN	Input Resistance, RIN	12	15		kΩ	
Transmitter Output						

VOD	Differential Output Voltage, dVOD	1.5		5	V	With $R_L = 54\Omega$. CL = 50pF *
ESD Tolerance						
ESD HBM	RS485 Inputs and Outputs		± 15		kV	
EN61000-4-2ContactDischarge	RS-485 Inputs and Outputs		± 8		kV	
EN61000-4-2AirGapDischarge	RS-485 Inputs and Outputs		± 15		kV	

Table 4.4 – RS485 Electrical Details

4.5 Power Output

The USB2-H-9002-M assigns the RI/PWR pin of the RS232 interface to provide +5V DC for an external device that requires power. It can also be used in RS485 mode. The maximum allowable current that can be supplied from the USB bus is 500mA, including the circuitry of the USB2-H-9002-M itself. Up to 250mA (total across 2 ports) may be used by the external devices.

To enable the power output for each port individually, ensure that:

- The USB2-H-9002-M is enumerated over USB
- The DIP switch for that channel is set to enable 5V out (see Table 2.1)
- The jumper for that channel is populated to enable the 5V output (see Table 2.2)

Parameter	Description	Minimum	Typical	Maximum	Units	Conditions
I_o	Output Power Current	0		250	mA	total available current for 2 ports

Table 4.5 – Power Output Option

5 Mechanical Details

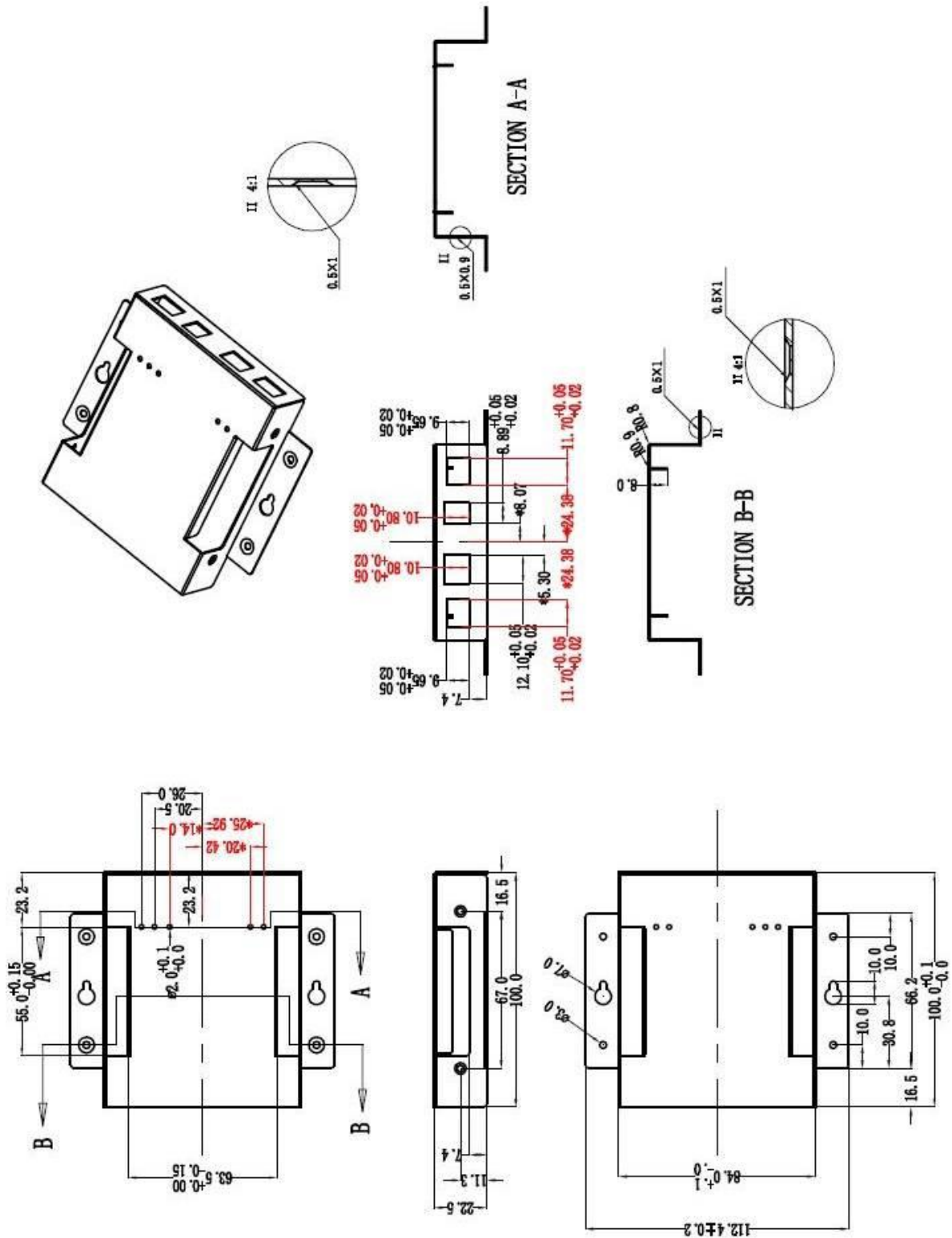

Figure 5.1 USB2-H-9002-M Case Dimensions - Top

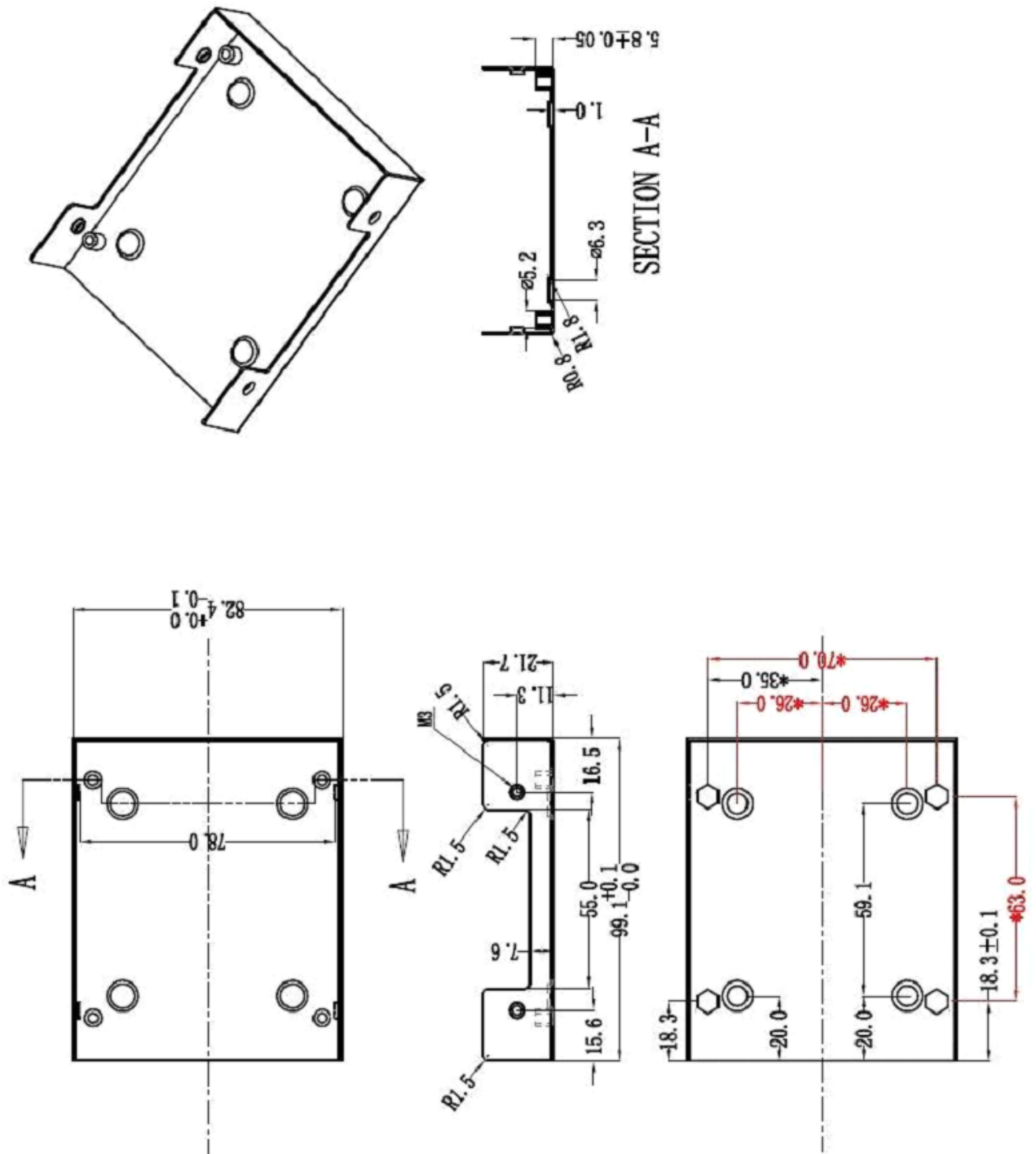

Figure 5.2 USB2-H-9002-M Case Dimensions - Bottom

6 Physical Environment Details

6.1 Storage Temperature

Parameter	Description	Minimum	Typical	Maximum	Units	Conditions
T	Storage Temperature Range		25		°C	Dry and dust-free space with a constant temperature and relative humidity less than 65%.

Table 6.1 – Storage Temperature

6.2 Operating Temperature

Parameter	Description	Minimum	Typical	Maximum	Units	Conditions
T	Operating Temperature Range	-40		+85	°C	5% to 95% RH, noncondensing

Table 6.2 – Operating Temperature

7 Environmental Approvals & Declarations

7.1 EMI Compatibility

FCC, CE and UKCA

The USB2-H-9002-M has been tested to be compliant with both FCC Part 15 Subpart B, European and UK EMC Directive.



NOTE: This is a Class B product. In a domestic environment, this product may cause radio interference, in which case the user may be required to take adequate measures.



NOTE: This equipment has been tested and found to comply with the limits for a Class B digital device, pursuant to Part 15 of the FCC Rules. These limits are designed to provide reasonable protection against harmful interference in a residential installation. This equipment generates uses and can radiate radio frequency energy and, if not installed and used in accordance with the instructions, may cause harmful interference to radio communications. However, there is no guarantee that interference will not occur in a particular installation. If this equipment does cause harmful interference to radio or television reception, which can be determined by turning the equipment off and on, the user is encouraged to try to correct the interference by one or more of the following measures:

- Reorient or relocate the receiving antenna.
- Increase the separation between the equipment and receiver.
- Connect the equipment into an outlet on a circuit different from that to which the receiver is connected.
- Consult the dealer or an experienced radio/TV technician for help.

7.2 Safety

The USB2-H-9002-M is defined as Limited Power Supply (LPS) device, with operating voltages under 60VDC.

7.3 Environmental

The USB2-H-9002-M is a lead-free device that complies with the following environmental directives: RoHS, WEEE, REACH, PFOS and DecaBDE.

7.4 Reliability

The USB2-H-9002-M is designed as a robust USB-Serial adaptor for use in many environments. There are no user-serviceable parts. Any failure will require a replacement of the unit.

7.5 Import / Export Information

Import / Export Information	
Country of Origin	China
Harmonized Code	8471.80.1000
Product Description	USB to RS232/RS485 Computer Adaptor, Dual Ports
USA ECCN	EAR99 - No License Required

Table 7.1 – Import / Export Information

8 Troubleshooting

8.1 Hardware

Cables are the most common sources of trouble with external devices.

Check the following:

- USB cable is properly inserted at both ends
- Computer powered is ON
- Computer is not in Sleep or Standby
- If a USB Hub is used, be sure it is set for "Self-Powered" operation
- If a USB Hub is used, be sure all cables are properly inserted
- If all the above are OK, the Yellow LED should be lit, indicating the device has been recognized by the USB subsystem.

RS485 cables – check the following:

- Check for specific handshake requirements of your RS485 peripheral.
- Because there are no handshake signals, ensure the application is not set for RTS/CTS or DTR/DSR handshake modes.
- Test the port with a loop-back connector. On RS485 this requires a second known-good port as RS485 cannot be directly looped back. Use a simple terminal program to check that data is transmitted and received.
 - o Connect DATA+ of the port being tested to DATA+ of the known-good RS485 port
 - o Connect DATA- of the port being tested to DATA- of the known-good RS485 port

RS232 cables – check the following:

- Output signals (TXD, RTS, DTR) are connected to the respective inputs (RXD, CTS, DSR) in each direction.
- Check for specific handshake requirements of your RS232 peripheral.
- If handshake signals are not used, ensure the application is set to "No Hardware Handshake", or equivalent.
- Test the port with a loop-back connector. Connect TXD to RXD, RTS to CTS and DTR to DSR. Use a simple terminal program to check that data is transmitted and received.

8.2 Device Driver

Ensure the latest device driver is in use. For instructions on how to remove and re-install the latest driver, refer to the **Connective Peripherals USB to Serial Converters Driver Installation Guide (CP_000084)** which is available from www.connectiveperipherals.com.

If other devices with FTDI chips are installed in the system, check with all manufacturers of these devices for the latest device drivers.

The FTDI installation guides also have additional information on driver installation: <https://ftdichip.com/document/installation-guides/>.

Common Windows Device Driver Troubles:

- **DEVICE TIMES OUT:** The default settings of the device driver assume typical data transfers of hundreds to thousands or more bytes at a given time. Some applications, such as a GPS device, only send data in short packets, often only a few bytes. If this is the case, it may be necessary to adjust the driver buffer size and/or latency timer to smaller values. These values can be adjusted through the advanced driver options which can be accessed by double-clicking on the device under the Ports (COM & LPT) section of the Windows Device Manager and clicking the advanced button in the Port Settings tab. The latency timer can be set as low as 2ms. A setting of 1ms will cause unnecessary USB traffic and could adversely affect data transmission.

- **ERRATIC MOUSE POINTER:** The device driver defaults to query an attached device to find out whether it is a mouse or modem, consistent with native COM port operation. Some serial peripherals constantly send short packets of data, causing the host system to “think” a mouse or modem has been attached. These short packets will interfere with normal mouse operation causing the pointer to jump around the screen. If this happens, disconnect the serial device, and *uncheck the Serial Enumerator* option. This setting is in the advanced driver options which can be accessed by double-clicking on the device under the Ports (COM & LPT) section of the Windows Device Manager and clicking the advanced button in the Port Settings tab.
- **COM PORT IN USE:** Windows keeps track of all COM port assignments. If multiple products have been connected to a single system, the COM port number will increase, even if the other devices are not attached. If the higher COM port assignments are not acceptable for the application, known unused COM port numbers can be uninstalled as shown in the **Connective Peripherals USB to Serial Converters Driver Installation Guide (CP_000084)** which is available from www.connectiveperipherals.com and the FTDI driver installation guides at <https://ftdichip.com/document/installation-guides/>.

8.3 Technical Support

Technical support may be obtained from your nearest Connective Peripherals office. See details below.

E-Mail (Support): support@connectiveperipherals.com

Web: <http://www.connectiveperipherals.com/products>

9 Contact Information

Global Headquarters – Singapore

Connective Peripherals Pte Ltd
178 Paya Lebar Road
#07-03
Singapore 409030

Tel: +65 67430980
Fax: +65 68416071

E-Mail (Sales)	sales@connectiveperipherals.com
E-Mail (Support)	support@connectiveperipherals.com
Web Site URL	http://www.connectiveperipherals.com
Web Shop URL	http://www.connectiveperipherals.com

Appendix A – List of Figures and Tables

List of Figures

Figure 1.1 USB2-H-9002-M	4
Figure 1.2 USB2-H-9002-M Block Diagram.....	5
Figure 2.1 – USB2-H-9002-M Brackets	9
Figure 5.1 USB2-H-9002-M Case Dimensions - Top.....	13
Figure 5.2 USB2-H-9002-M Case Dimensions - Bottom.....	14

List of Tables

Table 1.1 – LED Description	5
Table 1.2 – Performance Figures	7
Table 1.3 – Ordering Information.....	7
Table 2.1 – Switch Setting Configuration of the USB2-H-9002-M	8
Table 2.2 –Jumper Selection of USB2-H-9002-M.....	9
Table 3.1 – USB B Receptacle Pin-Out	10
Table 3.2 – Connections required for RS232 serial interface	10
Table 3.3 – Connector of RS485 Pin-Out.....	10
Table 4.1 – USB Electrical Details	11
Table 4.2 – PSU Input Details.....	11
Table 4.3 – RS232 Electrical Details	11
Table 4.4 – RS485 Electrical Details	12
Table 4.5 – Power Output Option	12
Table 6.1 – Storage Temperature	15
Table 6.2 – Operating Temperature	15
Table 7.1 – Import / Export Information	17

Appendix B – Revision History

Revision	Changes	Date
1.0	Initial release	08-09-2010
1.1	Re-branding to reflect the migration of the product from EasySync to Connective Peripherals name – logo change, copyright changed, contact information Changed, all internal hyperlinks changed.	20-03-2019
1.2	Replaced driver install section with link to Connective Peripherals USB to Serial Converters Driver Installation Guide (CP_000084). Updated storage temperature. Removed biasing jumpers from table 2.2. Updated to include UKCA mark.	21-10-2022