



USB2-H-5004 Hi-Speed USB to 4-Port RS485 Adapter Data Sheet

Document Reference No.: CP_000049

Version 1.4

Issue Date: 24-05-2024

The USB-COM-Plus adaptors are a family of communication devices from Connective Peripherals Pte Ltd. This model, USB2-H-5004, provides a simple method of adapting legacy serial devices with RS485 interfaces to modern USB ports by incorporating the FTDI FT4232H Hi-Speed USB bridge chip.

The adaptor provides four RS485 ports from a single USB port and features LED status indicators. A power supply output of +5VDC at up to 250mA (total shared between four ports) is available on the 9-pin D-sub connectors.

**Connective Peripherals Pte Ltd
1 Tai Seng Avenue, Tower A, #03-05, Singapore 536464
Tel.: +65 67430980**

E-Mail (Support): support@connectiveperipherals.com Web: www.connectiveperipherals.com/products

Neither the whole nor any part of the information contained in, or the product described in this manual, may be adapted, or reproduced in any material or electronic form without the prior written consent of the copyright holder. This product and its documentation are supplied on an as-is basis and no warranty as to their suitability for any particular purpose is either made or implied. Connective Peripherals Pte Ltd will not accept any claim for damages howsoever arising as a result of use or failure of this product. Your statutory rights are not affected. This product or any variant of it is not intended for use in any medical appliance, device, or system in which the failure of the product might reasonably be expected to result in personal injury. This document provides preliminary information that may be subject to change without notice. No freedom to use patents or other intellectual property rights is implied by the publication of this document. Connective Peripherals Pte Ltd, 1 Tai Seng Avenue, Tower A, #03-05, Singapore 536464. Registered Number: 201617872E

Table of Contents

| | | |
|----------|---|-----------|
| 1 | Introduction | 4 |
| 1.1 | Functional Description | 4 |
| 1.2 | LED Description | 5 |
| 1.3 | Block Diagram | 5 |
| 1.3.1 | Block description | 5 |
| 1.4 | Features | 6 |
| 1.5 | Performance Figures | 7 |
| 1.6 | Ordering Information | 7 |
| 2 | Installation | 8 |
| 2.1 | Hardware Installation | 8 |
| 2.1.1 | Mounting | 8 |
| 2.1.2 | Wiring | 9 |
| 2.2 | Device Driver Installation | 10 |
| 3 | Connections | 11 |
| 3.1 | External Connectors | 11 |
| 3.1.1 | USB | 11 |
| 3.1.2 | RS485 | 11 |
| 4 | Electrical details | 12 |
| 4.1 | USB | 12 |
| 4.2 | RS485 | 12 |
| 4.3 | Power Output | 13 |
| 5 | Mechanical Details | 14 |
| 5.1 | Module Mechanical Dimensions | 14 |
| 5.2 | UniClip™ Mechanical Dimensions | 15 |
| 6 | Physical Environment Details | 16 |
| 6.1 | Storage Temperature | 16 |
| 6.2 | Operating Temperature | 16 |
| 7 | Environmental Approvals & Declarations | 17 |
| 7.1 | EMI Compatibility | 17 |
| 7.2 | Safety | 17 |
| 7.3 | Environmental | 17 |

| | |
|--|-----------|
| 7.4 Reliability..... | 17 |
| 7.5 Import / Export Information | 18 |
| 8 Troubleshooting | 19 |
| 8.1 Hardware | 19 |
| 8.2 Device Driver | 19 |
| 8.3 Technical Support | 20 |
| 9 Contact Information..... | 21 |
| Appendix A - List of Figures and Tables | 22 |
| List of Figures | 22 |
| List of Tables | 22 |
| Appendix B - Revision History..... | 23 |

1 Introduction

1.1 Functional Description

The USB-COM-Plus adapters are a family of communication devices. This model, USB2-H-5004, provides a simple method of adapting legacy serial devices with RS485 interfaces to a modern USB 2.0 Hi-Speed port. This is accomplished by incorporating the industry standard FTDI FT4232H Hi-Speed USB-Serial bridge chip.

Each USB2-H-5004 adapter contains a small internal electronic circuit board which utilises the FTDI FT4232H, mounted inside a rugged plastic enclosure capable of withstanding industrial temperature ranges. The integrated electronics also include RS485 level shifters and TXD/RXD LEDs to provide a visual indication of data traffic through the adapter.



Figure 1.1 USB2-H-5004

Flexible mounting allows the USB2-H-5004 to be used in a variety of applications, from a portable adapter to accompany a laptop to permanent installations in industrial, commercial, and retail locations.

The enclosure incorporates a standard USB Mini-B client connector for connection to an upstream host or hub port. RS485-level signals are available on four industry-standard DE-9P connectors. The maximum RS485-level data rate is 8Mbps.

The USB2-H-5002 adapter requires USB device drivers, available free from <https://www.connectiveperipherals.com> which are used to make the USB2-H-5004 appear as a Virtual COM Port (VCP). This allows existing serial communications software, such as HyperTerminal, to exchange data through the USB2-H-5004 to legacy RS485 peripheral devices.

Pin 9 of the D-sub connector can provide +5V power output with maximum 250mA (total current shared between the four ports).

1.2 LED Description

The USB2-H-5004 uses 9 LEDs to indicate a valid link, as well as data traffic on any of the 4 RS485 interfaces, according to the following table:

| LED Color | Function | Description | quantity |
|-----------|--------------|--|----------|
| Yellow | Enumerated | ON when USB2-H-5004 is configured and ready | 1 |
| Red | TxD Activity | Flashes when data is transmitted from the USB2-H-5004 to the attached RS485 device | 4 |
| Green | RxD Activity | Flashes when data is transmitted from the attached RS485 device to the USB2-H-5004 | 4 |

Table 1.1 – LED Description

1.3 Block Diagram

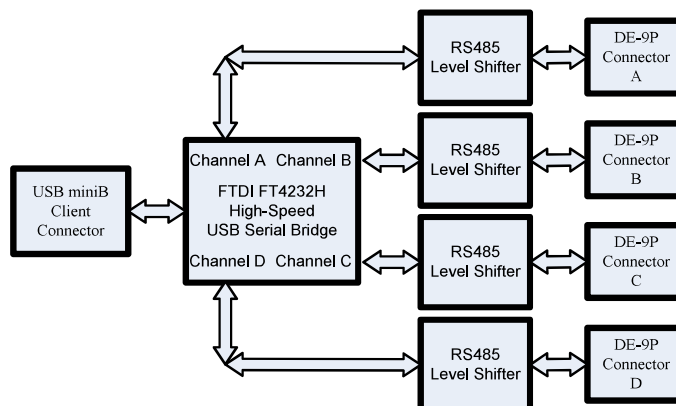

Figure 1.2 USB2-H-5004 Block Diagram

1.3.1 Block description

USB Mini-B Client Connector

This connector provides the interface for connection to a USB Host or Hub port. A standard "A to Mini-B" cable is provided, though one of a different length may also be used. The maximum cable length is 5 meters, according to the USB 2.0 specification.

FTDI FT4232H

The FTDI [FT4232H](#) provides the USB-to-Serial conversion. Operating system device drivers are required in order to work with the FT4232H to provide the Virtual COM Port serial functionality.

Quad RS485 Level Shifter

The RS485 level shifter converts the signals provided by the FT4232H into the voltage levels required by RS485 devices.

DE-9P Connector (Male)

The DE-9P connector is configured in an industry standard (TIA/EIA-485) pin-out to provide connection to RS485 peripherals through standard cables. See section 3.1.2

1.4 Features

- Adds quad RS-485 serial ports by connecting to a USB 2.0 Hi-Speed interface.
- Echo and non-Echo modes selection.
- Easy plug & play installation and RS-485 device connection
- Provides a USB2.0 Hi-Speed(480Mbps) interface and works with USB 1.1, 2.0 and 3.0 Host and Hub ports
- Industry Standard FTDI chip set & device drivers for maximum compatibility
- Microsoft Windows® WHQL-certified drivers (Windows 7 - Windows 11)
- Legacy drivers also available for older Windows versions back to XP, and Windows CE
- macOS and Linux device drivers
- Installs as four standard Windows COM ports
- COM port number can be changed to any available COM port number, to support HyperTerminal, or any other serial communications software application running in Windows
- FIFO: 2k byte transmit buffer, 2k byte receive buffer
- RS-485 data signals: Data+, Data-, GND
- Powered by USB port. No external power adapter required.
- Pin 9 of DE-9P can provide +5VDC output at 250mA (total on 4 ports)
- Serial port speed up to 8Mbps
- Serial Communication Parameters
 - Parity: None, Even, Odd
 - Data bits: 7, 8
 - Flow control: X-ON/X-OFF, None
- Four DE-9P male connectors
- LEDs indicate USB Enumeration, RxD, TxD for monitoring port status & easy diagnostics
- Operating temperature of -40°C to +85°C
- USB cable of 0.9 meter included
- FCC and CE approved.

1.5 Performance Figures

| Parameter | Performance |
|-----------------|---|
| USB Interface | 480Mbps USB 2.0 Hi-Speed |
| RS485 Interface | Standard Windows baud rates (300bps to 921.6Kbps) Custom baud rates (300bps to 8Mbps) through baud rate aliasing. See FTDI Application Note: Aliasing VCP Baud Rates |

Table 1.2 - Performance Figures

1.6 Ordering Information

| Part Number | Description |
|-------------|---|
| USB2-H-5004 | USB-COM-Plus Hi-Speed USB to 4-Port RS485 Adapter |

Table 1.3 - Ordering Information

2 Installation

2.1 Hardware Installation

There are no switches or jumpers to configure on the USB-COM-Plus USB2-H-5004.

2.1.1 Mounting

The USB2-H-5004 is provided with two mounting options: UniClip™ Wall/DIN rail mount and rubber feet. The UniClip Wall/DIN rail mount allows the USB2-H-5004 to be permanently mounted to a wall or attached to a DIN rail. The rubber feet can be used when mobility or desktop use is desired.

NOTE: The UniClip provides a permanent mounting style. The USB2-H-5004 case may be damaged if the UniClip is removed.

The following figures indicate various mounting styles.



Figure 2.1 - USB2-H-5004 with UniClip Brackets



Figure 2.2 - USB2-H-5004 with Rubber Feet

2.1.2 Wiring

A standard 0.9m USB "A" to "Mini B" cable is provided.

Insert the A-plug into an available USB Host or Hub port. Insert the Mini B-plug into the Mini-B receptacle on the USB2-H-5004.

| DTE Pin Number | Signal Name | Expected Connect Signal |
|----------------|---|---|
| 1 | DATA- = Transmit/Receive Data, negative polarity Also Terminator 2 | DATA- Pin 2 of 120R Terminating Resistor. Only Required if the USB2-H-5004 is the first or last device in a multi-drop RS485 System, to meet RS485 Termination Requirements. |
| 2 | DATA+ = Transmit/Receive Data, positive polarity | DATA+ |
| 3 | Terminator 1 | Pin 1 of 120R Terminating Resistor. Only Required if the USB2-H-5004 is the first or last device in a multi-drop RS485 System, to meet RS485 Termination Requirements. |
| 4 | N/A | N/A |
| 5 | GND = signal ground | GND |
| 6 | N/A | N/A |
| 7 | echo disable terminal 1 | Local echo function control. Connect to pin 8 to disable the local echo function. The local echo is enabled by default. |
| 8 | echo disable terminal 2 | Local echo function control. Connect to pin 7 to disable the local echo function. The local echo is enabled by default. |
| 9 | PWR = +5V DC output | PWR |

Table 2.1 – RS485 DTE to DCE connection

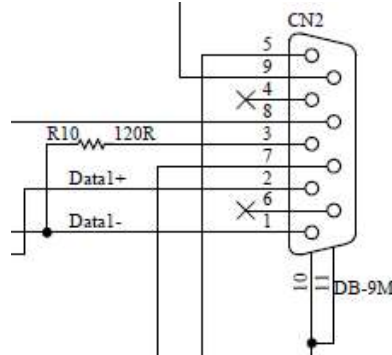

Figure 2.3 USB2-H-5004 Termination resistor

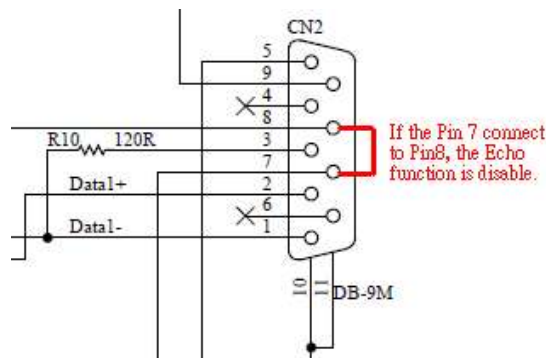

Figure 2.4 USB2-H-5004 Echo disable

2.2 Device Driver Installation

For driver installation, please refer to the **Connective Peripherals USB to Serial Converters Driver Installation Guide (CP_000084)** which is available from www.connectiveperipherals.com

3 Connections

3.1 External Connectors

3.1.1 USB

The USB-H-5004 is a downstream USB 2.0 Device. A standard USB Series "Mini B" receptacle is mounted inside the USB-H-5004 to facilitate connection to an upstream USB Host or Hub.

| Pin Number | Pin Type | Description |
|------------|---------------|---|
| 1 | Power | VBUS – USB Power provided from upstream USB Host or Hub |
| 2 | Bidirectional | D– = USB data signal, negative polarity |
| 3 | Bidirectional | D+ = USB data signal, positive polarity |
| 4 | ID | Not connected |
| 5 | Ground | GND = USB signal ground |
| Shield | Case Ground | Drain = typically connected to the host PC case |

Table 3.1 – USB "Mini B" Receptacle Pin-Out

3.1.2 RS485

The RS485 port is configured as Data Terminal Equipment (DTE), with a 9-contact D-Sub Pin connector. Pin assignments are according to TIA/EIA-485.

In addition, Pin9 of this connector can provide +5VDC to an external device with a maximum current draw of 250mA (total across all four ports combined) once the USB2-H-5004 has been enumerated by the system.

| Pin Number | Pin Type | Description |
|------------|---------------------|---|
| 1 | Input/Output | DATA- Pin 2 of 120R Terminating Resistor. Only Required if the USB2-H-5004 is the first or last device in a multi-drop RS485 System, to meet RS485 Termination Requirements. |
| 2 | Input/Output | DATA+ |
| 3 | Input | Pin 1 of 120R Terminating Resistor. Only Required if the USB2-H-5004 is the first or last device in a multi-drop RS485 System, to meet RS485 Termination Requirements. |
| 4 | N/A | N/A |
| 5 | GND = signal ground | GND |
| 6 | N/A | N/A |
| 7 | Input | Local echo control input pin. Connect to pin 8 to disable local echo. Default is that local echo is enabled. |
| 8 | Output | Local echo control output pin. Connect to pin 7 to disable local echo. Default is that local echo is enabled. |
| 9 | PWR = +5V DC output | PWR |

Table 3.2 – DE-9P RS485 Pin-Out

4 Electrical details

4.1 USB

| Parameter | Description | Minimum | Typical | Maximum | Units | Conditions |
|-----------------|----------------------|---------|---------|---------|-------|---|
| USB_VCC | Input Power Voltage* | 4.25 | 5.0* | 5.25 | V | *Present when USB cable is attached, and USB Host or Hub powered. |
| I _{cc} | USB current | | 85 | | mA | Unit connected to USB port and idle (no RS485 cabling connected and no data transfer) |
| | | | 90 | | mA | 4 ports running at 1MBaud (loopback through the echo feature). Actual current consumption depends on the characteristics of the RS485 cabling and attached devices. |

Table 4.1 - USB Electrical Details

4.2 RS485

| Parameter | Description | Minimum | Typical | Maximum | Units | Conditions |
|-----------------------------|-------------------------------------|---------|---------|---------|-------|----------------------------|
| Receiver Input | | | | | | |
| VCM | Common-mode input voltage range | -7 | +12 | | V | |
| IN | Input Current | | | 1.0 | mA | VIN = +12V |
| | | | | -0.8 | | VIN = -7V |
| VTH | Differential Threshold Voltage, VTH | -0.2 | | +0.2 | V | |
| VIHYST | Input Hysteresis | | 20 | | mV | |
| RIN | Input Resistance, RIN | 12 | 15 | | kΩ | |
| Transmitter Output | | | | | | |
| VOD | Differential Output Voltage, dVOD | 1.5 | | 5 | V | With RL = 54Ω. CL = 50pF * |
| ESD Tolerance | | | | | | |
| ESD HBM | RS485 Inputs and Outputs | | ±15 | | kV | |
| EN61000-4-2ContactDischarge | RS-485 Inputs and Outputs | | ±8 | | kV | |
| EN61000-4-2AirGapDischarge | RS-485 Inputs and Outputs | | ±15 | | kV | |

Table 4.2 - RS485 Electrical Details

4.3 Power Output

The USB2-H-5004 assigns pin 9 of each DE-9P to provide +5V DC for an external device that requires power.

The maximum allowable current that can be supplied from the USB bus is 500mA, including the circuitry of the USB2-H-5004 itself. Up to 250mA (total across 4 ports) may be used by the external devices.

| Parameter | Description | Minimum | Typical | Maximum | Units | Conditions |
|-----------|----------------------|---------|---------|---------|-------|---|
| I_o | Output Power Current | 0 | | 250 | mA | Total current (combined across all RS485 ports) |

Table 4.3 - Power Output Option

5 Mechanical Details

5.1 Module Mechanical Dimensions

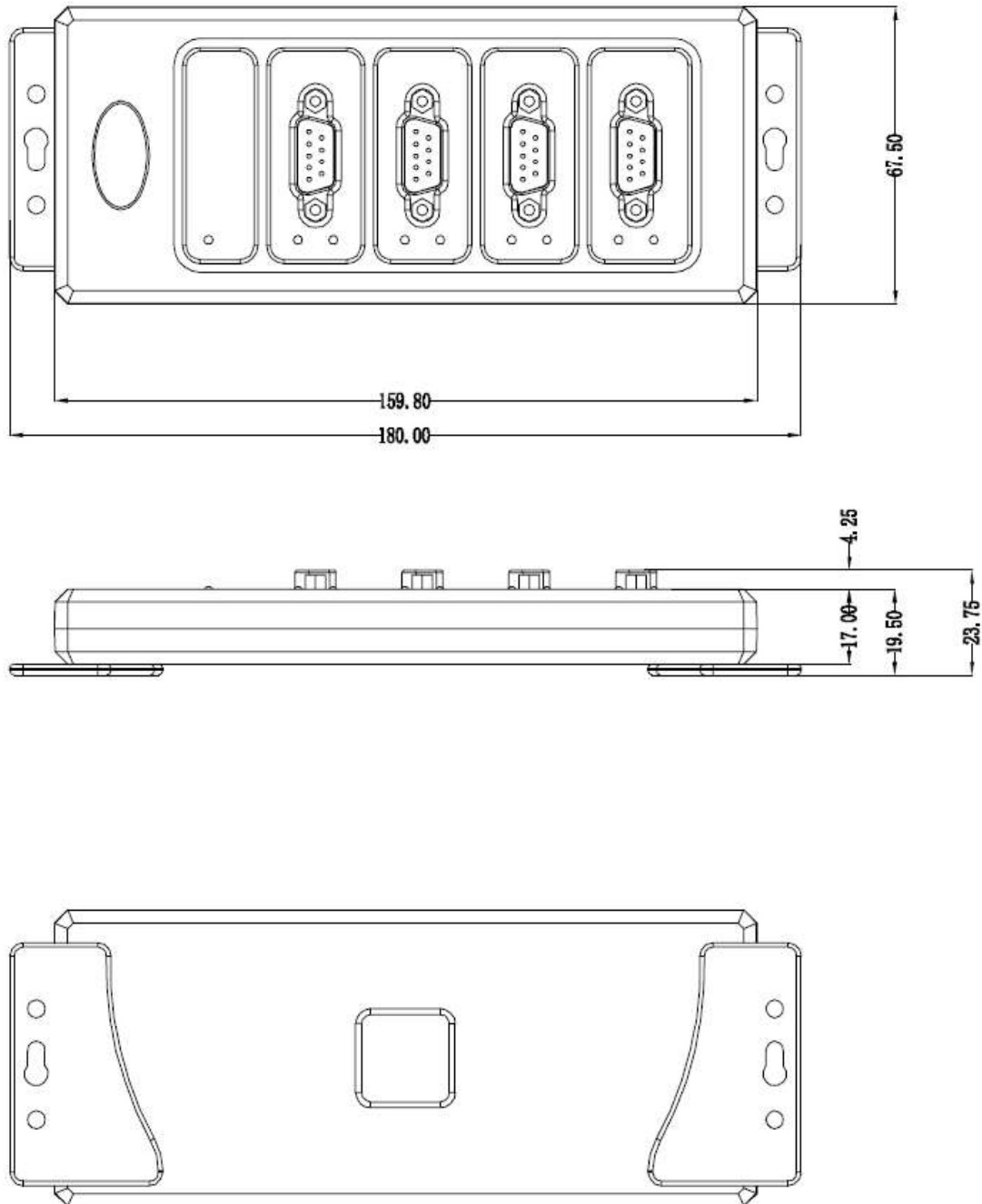

Figure 5.1 USB2-H-5004 Case Dimensions

Dimensions are shown in mm.

5.2 UniClip™ Mechanical Dimensions

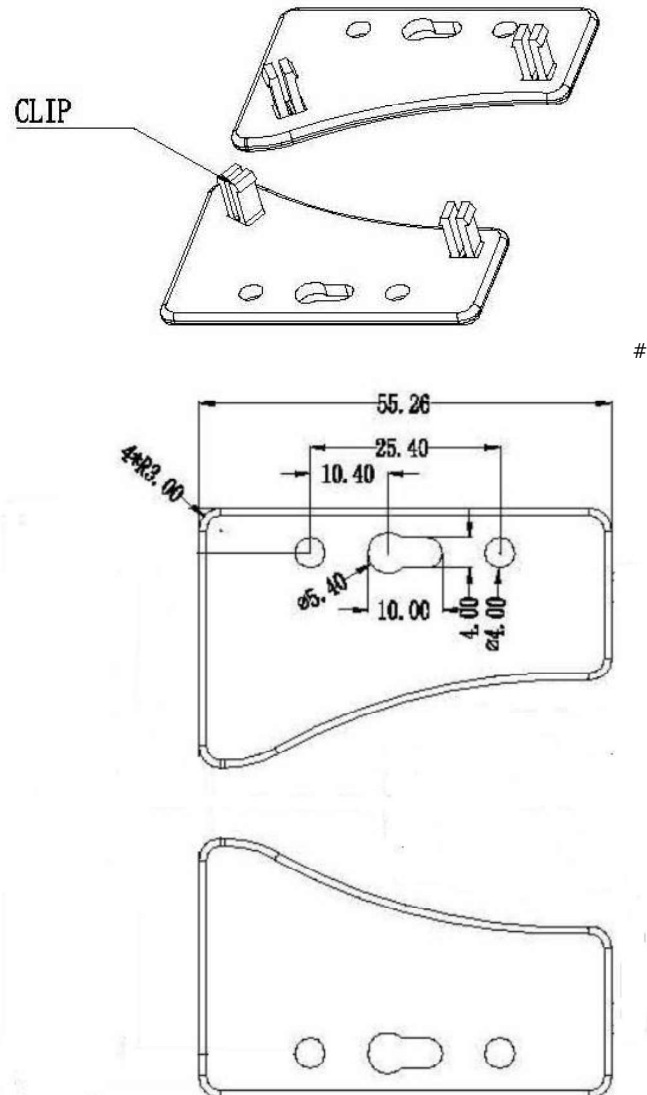

Figure 5.2 USB2-H-5004 Case Dimensions with UniClip

The UniClips are symmetrical. Dimensions (in mm) are shown for one UniClip only for clarity.

6 Physical Environment Details

6.1 Storage Temperature

| Parameter | Description | Minimum | Typical | Maximum | Units | Conditions |
|-----------|---------------------------|---------|---------|---------|-------|--|
| T | Storage Temperature Range | | 25 | | °C | Dry and dust-free space with a constant temperature and relative humidity less than 65%. |

Table 6.1 - Storage Temperature

6.2 Operating Temperature

| Parameter | Description | Minimum | Typical | Maximum | Units | Conditions |
|-----------|-----------------------------|---------|---------|---------|-------|-----------------------------|
| T | Operating Temperature Range | -40 | | +85 | °C | 5% to 95% RH, noncondensing |

Table 6.2 - Operating Temperature

7 Environmental Approvals & Declarations

7.1 EMI Compatibility

FCC and CE

The USB2-H-5004 has been tested to be compliant with both FCC Part 15 Subpart B and European EMC Directive.



NOTE: This is a Class B product. In a domestic environment, this product may cause radio interference, in which case the user may be required to take adequate measures.



NOTE: This equipment has been tested and found to comply with the limits for a Class B digital device, pursuant to Part 15 of the FCC Rules. These limits are designed to provide reasonable protection against harmful interference in a residential installation. This equipment generates, uses, and can radiate radio frequency energy and, if not installed and used in accordance with the instructions, may cause harmful interference to radio communications. However, there is no guarantee that interference will not occur in a particular installation. If this equipment does cause harmful interference to radio or television reception, which can be determined by turning the equipment off and on, the user is encouraged to try to correct the interference by one or more of the following measures:

- Reorient or relocate the receiving antenna.
- Increase the separation between the equipment and receiver.
- Connect the equipment into an outlet on a circuit different from that to which the receiver is connected.
- Consult the dealer or an experienced radio/TV technician for help.

7.2 Safety

The USB2-H-5004 is defined as Limited Power Supply (LPS) device, with operating voltages under 60VDC.

7.3 Environmental

The USB2-H-5004 is a lead-free device that complies with the following environmental directives: RoHS, WEEE, REACH, PFOS and DecaBDE.

7.4 Reliability

The USB2-H-5004 is designed as a robust USB-Serial adapter for use in many environments. There are no user-serviceable parts. Any failure will require a replacement of the unit.

7.5 Import / Export Information

| Import / Export Information | |
|-----------------------------|---|
| Country of Origin | China |
| Harmonized Code | TBD |
| Product Description | USB to RS485 Computer Adapter, Four Ports |
| USA ECCN | EAR99 – No License Required |

Table 7.1 - Import / Export Information

8 Troubleshooting

8.1 Hardware

Cables are the most common sources of trouble with external devices. Check the following:

- USB cable is properly inserted at both ends
- Computer power is ON
- Computer is not in Sleep or Standby
- If a USB Hub is used, be sure it is set for "Self-Powered" operation
- If a USB Hub is used, be sure all cables are properly inserted
- If all the above are OK, the Yellow LED should be lit, indicating the device has been recognized by the USB subsystem.

RS485 cables – check the following:

- Check for specific handshake requirements of your RS485 peripheral.
- Because there are no handshake signals, ensure the application is set to "No Hardware Handshake," or equivalent.
- Test the port with a loop-back connector connected between the port to be tested and another of the ports on the unit. Connect DATA+ of the port to be tested to DATA+ of the second port. Connect DATA- of the port to be tested to DATA- of the second port. Use a simple terminal program to check that data is transmitted and received between the port under test and the other port.

8.2 Device Driver

Ensure the latest device driver is in use. For instructions on how to remove and re-install the latest driver, refer to the **Connective Peripherals USB to Serial Converters Driver Installation Guide (CP_000084)** which is available from www.connectiveperipherals.com.

If other devices with FTDI chips are installed in the system, check with all manufacturers of these devices for the latest device drivers.

The FTDI installation guides also have additional information on driver installation: <https://ftdichip.com/document/installation-guides/>.

Common Windows Device Driver Troubles:

- **DEVICE TIMES OUT:** The default settings of the device driver assume typical data transfers of hundreds to thousands or more bytes at a given time. Some applications, such as a GPS device, only send data in short packets, often only a few bytes. If this is the case, it may be necessary to adjust the driver buffer size and/or latency timer to smaller values. These values can be adjusted through the advanced driver options which can be accessed by double-clicking on the device under the Ports (COM & LPT) section of the Windows Device Manager and clicking the advanced button in the Port Settings tab. The buffer size can be reduced to 64 bytes. The latency timer can be set as low as 2ms. A setting of 1ms will cause unnecessary USB traffic and could adversely affect data transmission.
- **ERRATIC MOUSE POINTER:** The device driver defaults to query an attached device to find out whether it is a mouse or modem, consistent with native COM port operation. Some RS232 peripherals constantly send short packets of data, causing the host system to "think" a mouse or modem has been attached. These short packets will interfere with normal mouse operation causing the pointer to jump around the screen. If this happens, disconnect the RS232 device, and *uncheck the Serial Enumerator* option. This setting is in the advanced driver options which can be accessed by double-clicking on the device under the Ports (COM & LPT) section of the Windows Device Manager and clicking the advanced button in the Port Settings tab.

- COM PORT IN USE: Windows keeps track of all COM port assignments. If multiple products have been connected to a single system, the COM port number will increase, even if the other devices are not attached. If the higher COM port assignments are not acceptable for the application, known unused COM port numbers can be uninstalled as shown in the **Connective Peripherals USB to Serial Converters Driver Installation Guide (CP_000084)** which is available from www.connectiveperipherals.com and the FTDI driver installation guides at <https://ftdichip.com/document/installation-guides/>.

8.3 Technical Support

Technical support may be obtained from your nearest Connective Peripherals office. See details below.

E-Mail (Support): support@connectiveperipherals.com

Web: <http://www.connectiveperipherals.com>

9 Contact Information

Global Headquarters – Singapore

Connective Peripherals Pte Ltd
1 Tai Seng Avenue, Tower A
#03-05
Singapore 536464

Tel: +65 67430980

E-Mail (Sales)
E-Mail (Support)
Web Site URL
Web Shop URL

sales@connectiveperipherals.com
support@connectiveperipherals.com
<http://www.connectiveperipherals.com>
<http://www.connectiveperipherals.com>

Appendix A - List of Figures and Tables

List of Figures

| | |
|---|----|
| Figure 1.1 USB2-H-5004..... | 4 |
| Figure 1.2 USB2-H-5004 Block Diagram | 5 |
| Figure 2.1 - USB2-H-5004 with UniClip Brackets..... | 8 |
| Figure 2.2 - USB2-H-5004 with Rubber Feet | 8 |
| Figure 2.3 USB2-H-5004 Termination resistor | 9 |
| Figure 2.4 USB2-H-5004 Echo disable | 9 |
| Figure 5.1 USB2-H-5004 Case Dimensions..... | 14 |
| Figure 5.2 USB2-H-5004 Case Dimensions with UniClip | 15 |

List of Tables

| | |
|--|----|
| Table 1.1 – LED Description | 5 |
| Table 1.2 - Performance Figures | 7 |
| Table 1.3 - Ordering Information | 7 |
| Table 2.1 – RS485 DTE to DCE connection | 9 |
| Table 3.1 – USB "Mini B" Receptacle Pin-Out..... | 11 |
| Table 3.2 – DE-9P RS485 Pin-Out | 11 |
| Table 4.1 - USB Electrical Details..... | 12 |
| Table 4.2 – RS485 Electrical Details | 12 |
| Table 4.3 - Power Output Option | 13 |
| Table 6.1 - Storage Temperature..... | 16 |
| Table 6.2 - Operating Temperature..... | 16 |
| Table 7.1 - Import / Export Information | 18 |

Appendix B - Revision History

| Revision | Changes | Date |
|----------|--|------------|
| 1.0 | Initial release | 15-09-2009 |
| 1.1 | Modified the description of Echo function Changed module colours and images to silver/black | 25-01-2010 |
| 1.2 | Re-branding to reflect the migration of the product from EasySync to Connective Peripherals name – logo change, copyright changed, contact information Changed, all internal hyperlinks changed. | 26-03-2019 |
| 1.3 | Replaced driver install section with link to Connective Peripherals USB to Serial Converters Driver Installation Guide (CP_000084). Updated current consumption and storage temperature. | 22-08-2022 |
| 1.4 | Updated Address | 24-05-2024 |