



# LDSBus Trailing Edge Light Dimmer Datasheet



## 1 Introduction

LDSBus Trailing Edge Light Dimmer can be integrated with dimmable LED lamps for adjusting the percentage of light dimming. Our trailing edge technology uses a current that is turned off when the AC waveform ends. The operation is smoother, soft starting and silent. It can control up to 550W@240VAC or 230W@100VAC for single-change loading.

The LDSBus Trailing Edge Light Dimmer has a 2-digit display to show the percentage of dimming.

Zero crossing detection determines whether the AC input frequency is 50Hz or 60Hz before enabling dimming.

Additionally, an external dimmer controller can be used to control light dimming.

## 1.1 Features

- Suitable for dimmable LEDs and lamps with single channel AC inputs and loading
- Trailing edge AC control to provide smooth dimming control
- Detects zero crossings and produces symmetrical pulses around them
- LED indicators indicate 50Hz or 60Hz AC
- 2 Digit dimming percentage display
- UP/DOWN push buttons for manual override of dimming
- Support for external dimmer control with UP/DOWN connectors
- BRTSYS LDSBus protocol. Data/power transmission via the LDSBus HVT-Junction
- Low power consumption
- Operating temperature range : 0°C to +55°C
- Flush mount and DIN Rail mounting options
- Supported platforms: BRTSYS IoTPortal, PanL Smart Living and LDSBus Python SDK  
Visit <https://brtsys.com/resources> for more information



Neither the whole nor any part of the information contained in, or the product described in this manual, may be adapted, or reproduced in any material or electronic form without the prior written consent of the copyright holder. This product and its documentation are supplied on an as-is basis and no warranty as to their suitability for any particular purpose is either made or implied. BRT Systems Pte Ltd will not accept any claim for damages howsoever arising as a result of use or failure of this product. Your statutory rights are not affected. This product or any variant of it is not intended for use in any medical appliance, device, or System in which the failure of the product might reasonably be expected to result in personal injury. This document provides preliminary information that may be subject to change without notice. No freedom to use patents or other intellectual property rights is implied by the publication of this document. BRT Systems Pte Ltd, 178 Paya Lebar Road, #07-03, Singapore 409030. Singapore Registered Company Number: 202220043R.

## 2 Part Numbers

Part#	Naming
LC030101A	LDSBus Trailing Edge Light Dimmer
LA120101A	LDSBus DIN Rail Mount Set

## Table of Contents

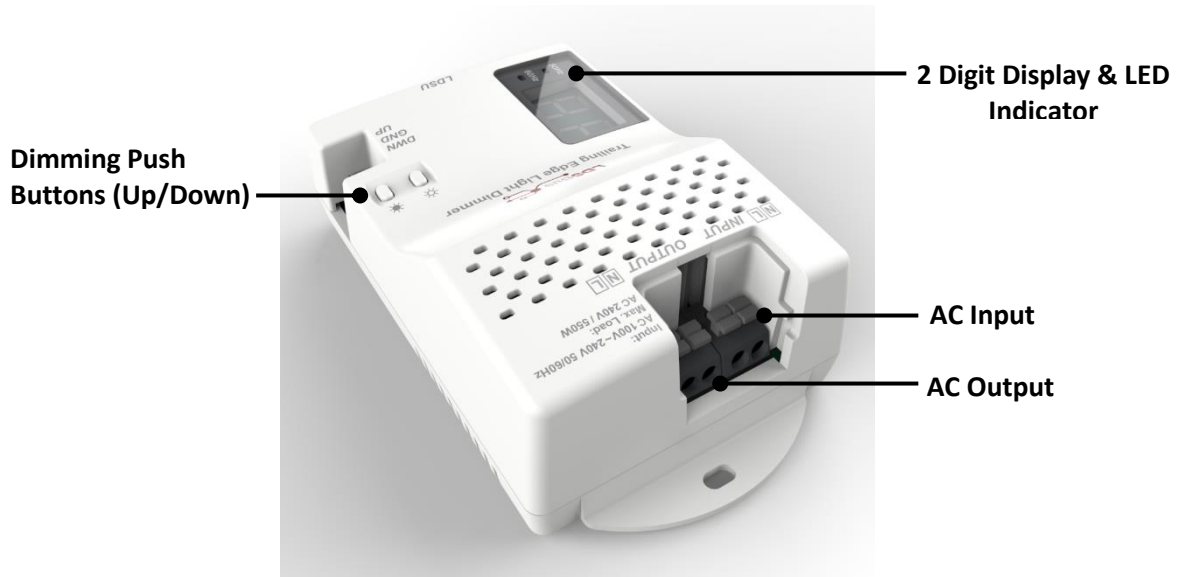
<b>1</b>	<b>Introduction .....</b>	<b>1</b>
1.1	Features .....	1
<b>2</b>	<b>Part Numbers .....</b>	<b>2</b>
<b>3</b>	<b>Product Specifications .....</b>	<b>4</b>
<b>4</b>	<b>Hardware Features .....</b>	<b>5</b>
<b>5</b>	<b>Configuration and Installation.....</b>	<b>6</b>
<b>6</b>	<b>Mounting Options .....</b>	<b>7</b>
6.1	Flush Mount.....	7
6.2	DIN Rail Mount.....	7
<b>7</b>	<b>Terminal Wiring Instructions on AC Input &amp; Output ..</b>	<b>8</b>
7.1	AC Input and Output Setup .....	9
<b>8</b>	<b>Terminal Wiring Instructions on External Dim Up/Down .....</b>	<b>10</b>
8.1	External Dimming Up/Down Setup.....	11
<b>9</b>	<b>LED Display .....</b>	<b>12</b>
<b>10</b>	<b>Mechanical Dimension .....</b>	<b>13</b>
<b>11</b>	<b>Contact Information .....</b>	<b>14</b>
<b>Appendix A – References .....</b>		<b>15</b>
Document References .....		15
Acronyms and Abbreviations.....		15
<b>Appendix B – List of Tables &amp; Figures .....</b>		<b>16</b>
List of Tables.....		16
List of Figures .....		16
<b>Appendix C – Revision History .....</b>		<b>17</b>

### 3 Product Specifications

<b>Features</b>	Interface	RS485
	50Hz indicator	Red LED
	60Hz indicator	Red LED
	Dimming Indicator	2 digit 7-segment LED display
	Buttons	UP / DOWN
	Mounting	Flush Mount DIN-Rail Mount
<b>Power</b>	Input Voltage	5V DC Bus Power
	Typical Power	390mW
	Max. Power	625mW
<b>AC Input</b>	Input Voltage	100VAC - 240VAC
	Frequency	50Hz/ 60Hz, +/- 3Hz
<b>AC Output</b>	Max. Load	550W@240VAC
	Max. Current	2.30A
<b>Dimming Range</b>	Percentage	0% - 99% and FULL
<b>Physical Characteristics</b>	Color	White
	Housing	Polycarbonate
	Dimension	L138.2mm x W76mm x H41.7mm
<b>Environmental Limits</b>	Operating Temperature	0 to 55°C
	Storage Temperature	-20 to 85°C
	Ambient Relative Humidity	5 to 95% (non-condensing)
<b>Package Contents</b>	Device	1x LDSBus Trailing Edge Light Dimmer
	Installation (Optional)	1x Din Rail Bracket set
	Wire Assembly	1X 5m RJ11 Cable
	Warranty label	1

**Table 1 - LDSBus Trailing Edge Light Dimmer Specifications**

## 4 Hardware Features



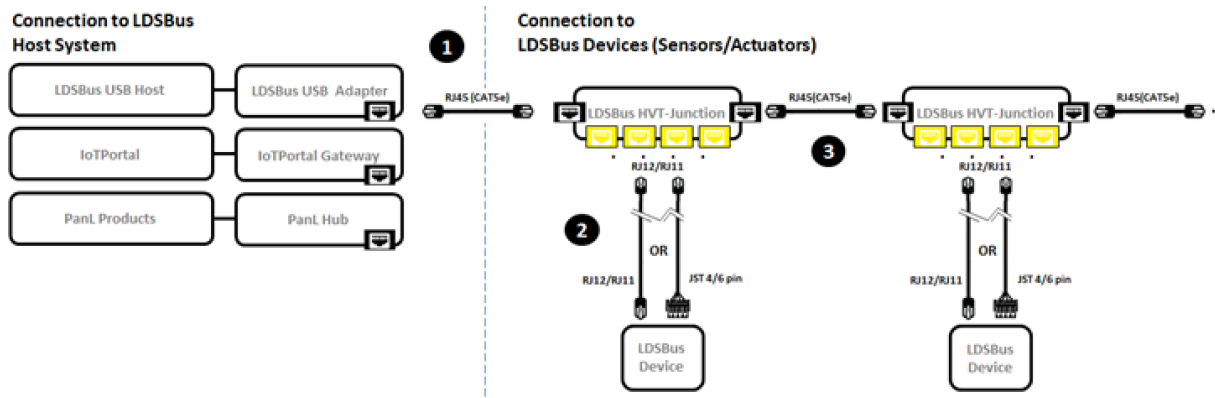
**Figure 1 - LDSBus Trailing Edge Light Dimmer Controller**

## 5 Configuration and Installation

Please visit <https://brtsys.com/resources> to access the LDSBus Configuration Utility guide on how to configure the device name, device address and termination settings before using it for your application.

### 5.1 Connection Diagram

Figure 2 illustrates the connection of the LDSBus Trailing Edge Light Dimmer (LDSBus Device) to the LDSBus. Please visit <https://brtsys.com/resources> to view the full device application, setup and installation guides.



**Figure 2 - LDSBus Trailing Edge Light Dimmer - Connection Diagram**

**Setup Instructions:**

1. Connect the first LDSBus HVT-Junction to any of the LDSBus Host Systems using a RJ45(CAT5e) cable.
2. Connect the configured LDSBus Trailing Edge Light Dimmer to the LDSBus HVT-Junction as shown in Figure 2.
3. If there is more than one LDSBus HVT-Junction, chain them together as shown in Figure 2.
4. Enable terminator for the last device in LDSBus.

## 6 Mounting Options

### 6.1 Flush Mount

The LDSBus Trailing Edge Light Dimmer can be flush mounted directly on a wall or any flat surface using 2 M3.5\*16mm (thread) screws.



**Figure 3 - LDSBus Trailing Edge Light Dimmer Flush Mount**

### 6.2 DIN Rail Mount

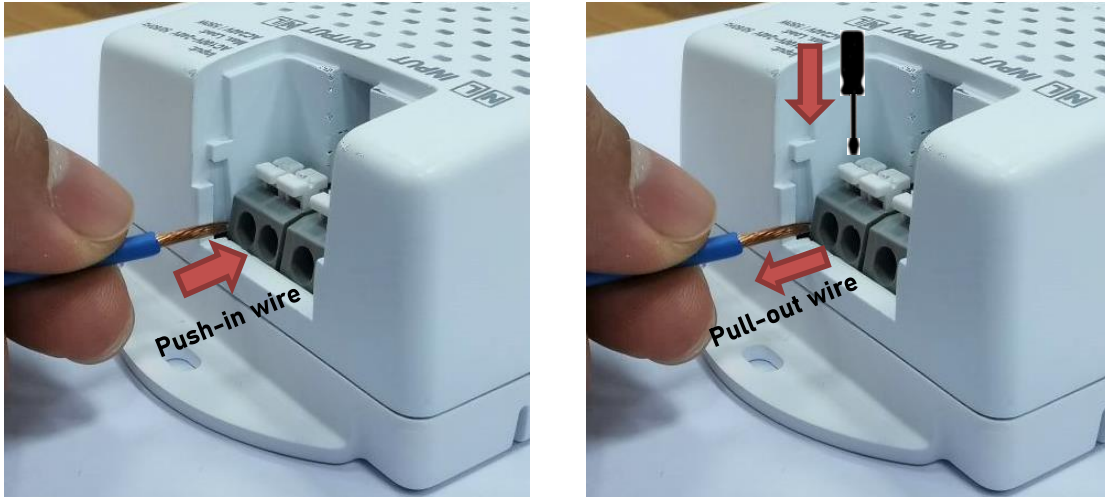
The DIN Rail Mount can be fixed using a DIN Rail bracket that has two mounting holes. The package includes mounting screws and a backplate. (The DIN Rail Bracket is not included in the package).



**Figure 4 - LDSBus Trailing Edge Light Dimmer DIN Rail Mount**

## 7 Terminal Wiring Instructions on AC Input & Output

The connections are made with Push-in CAGE CLAMP technology. When using solid conductor wire or stranded wire insulation ferrule, the stripped conductor can simply be inserted into the clamp until it hits the backstop without requiring a screwdriver. Figure 5 shows how to remove the cable from the connector using a flat head screwdriver to push the push buttons and pull out the wire.



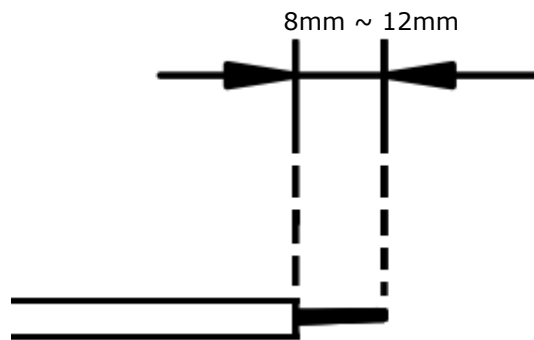
**Figure 5 - Push-in Wire and Pull-out Wire**

Table 2 provides a list of American Wire Gauges (AWGs) that can be used in the Terminal Blocks on AC Input and Output load.

Conductor Type	Wire diameter/AWG
Solid conductor	0.25~2.5mm <sup>2</sup> /20~12 AWG
Stranded conductor	0.25~2.5mm <sup>2</sup> /20~12 AWG
Stranded conductor; with insulated ferrule	0.25~1.5mm <sup>2</sup>

**Table 2 - AWG to use in terminal block on AC Input and Output load**

As shown in Figure 6, the wire strip is 8mm to 12mm long.



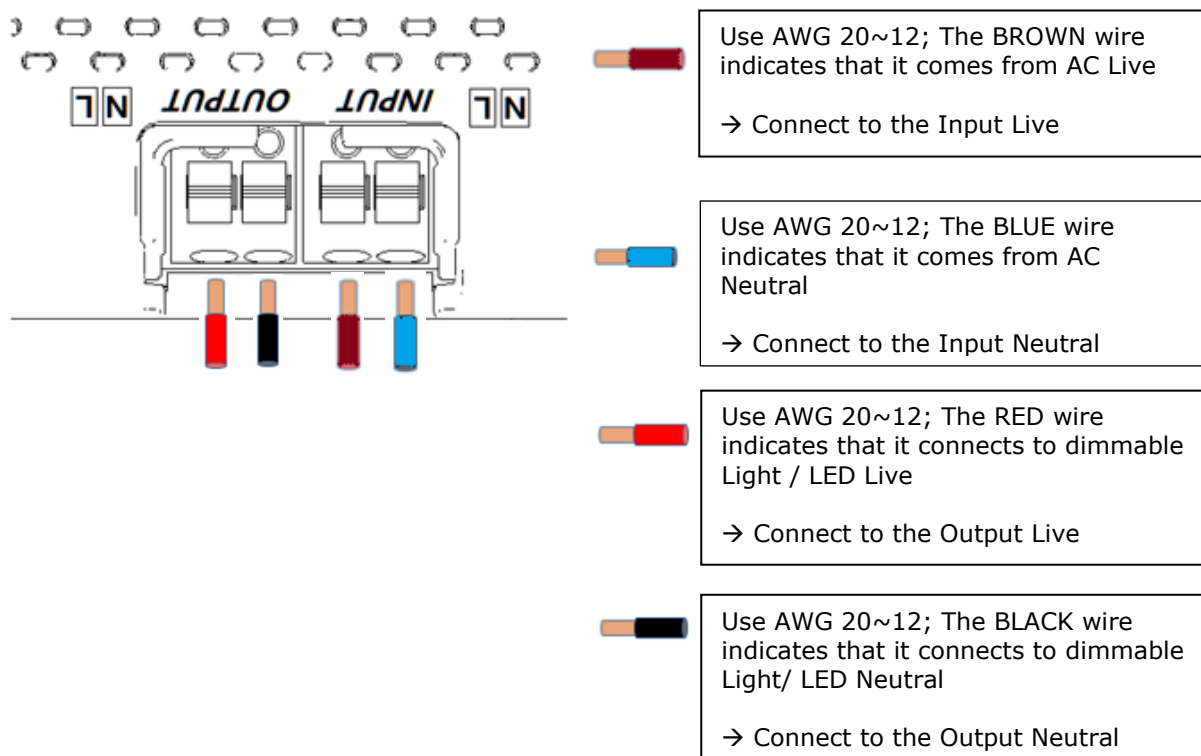
**Figure 6 - 8mm to 12mm wire strip**



## 7.1 AC Input and Output Setup

The AC terminals support AC 100VAC – 240VAC input and dimmable lights and LEDs on the output. The connection is illustrated below:

**Note:** Ensure that the dimmable light/LED is compatible with the AC voltage connected to the input terminal when selecting it.



## 8 Terminal Wiring Instructions on External Dim Up/Down

The terminal block is connected by screws. Figure 7 shows how to clamp the wire using a 0.4mm x 2.5mm slotted screwdriver and rotate in a clockwise direction. To release the wire, turn anticlockwise.



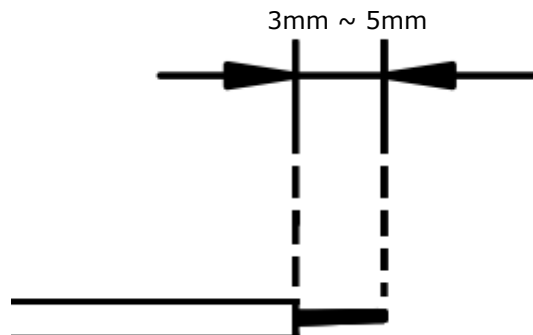
**Figure 7 - Clamping wire with screwdriver in clockwise direction**

Table 3 provides a list of American Wire Gauges (AWGs) that can be used in Terminal Blocks on External Dim Up / down.

Conductor Type	Wire diameter/AWG
Solid conductor	0.2~1.5mm <sup>2</sup> /26~16 AWG
Stranded conductor	0.2~1.5mm <sup>2</sup> /26~16 AWG
Stranded conductor; with insulated ferrule	0.25~0.75mm <sup>2</sup>

**Table 3 - AWG to use in terminal blocks on external Dim up/down**

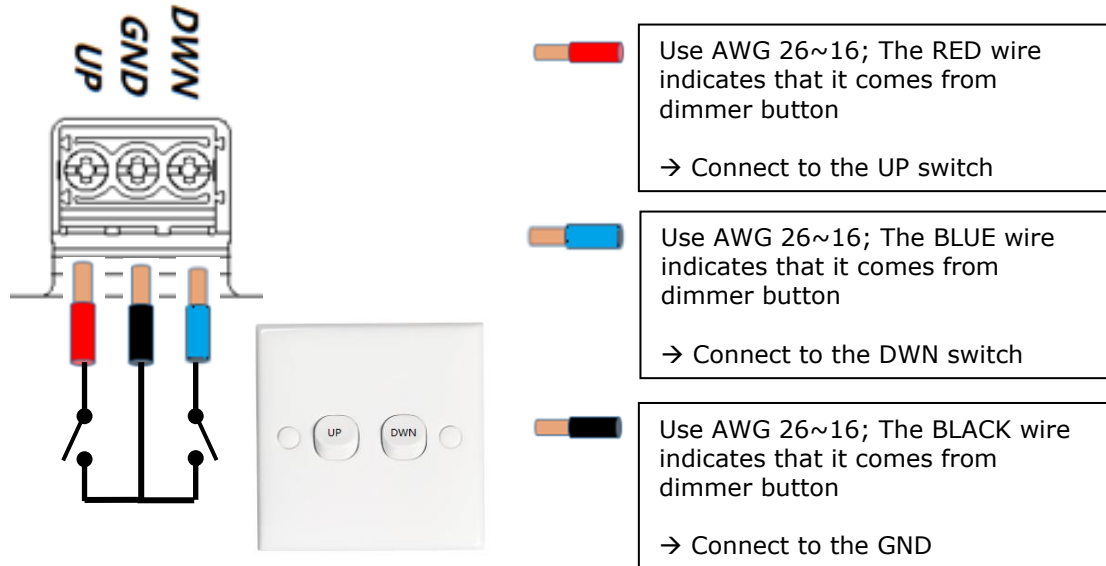
As shown in Figure 8, the wire strip is 3mm to 5mm long.



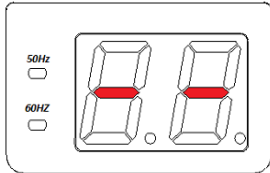
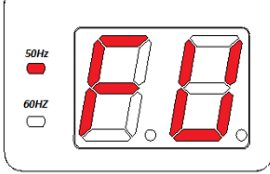
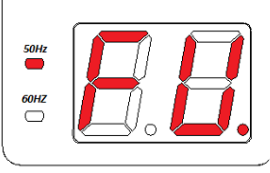

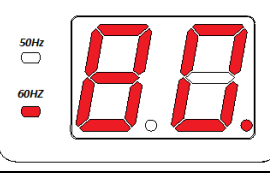
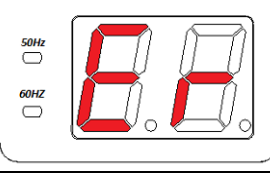
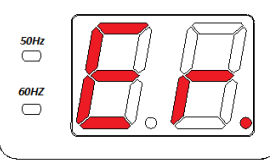
**Figure 8 - 3mm to 5mm wire strip**

## 8.1 External Dimming Up/Down Setup

A dimmable external connector supports UP / DOWN dimming. The connection is illustrated below:



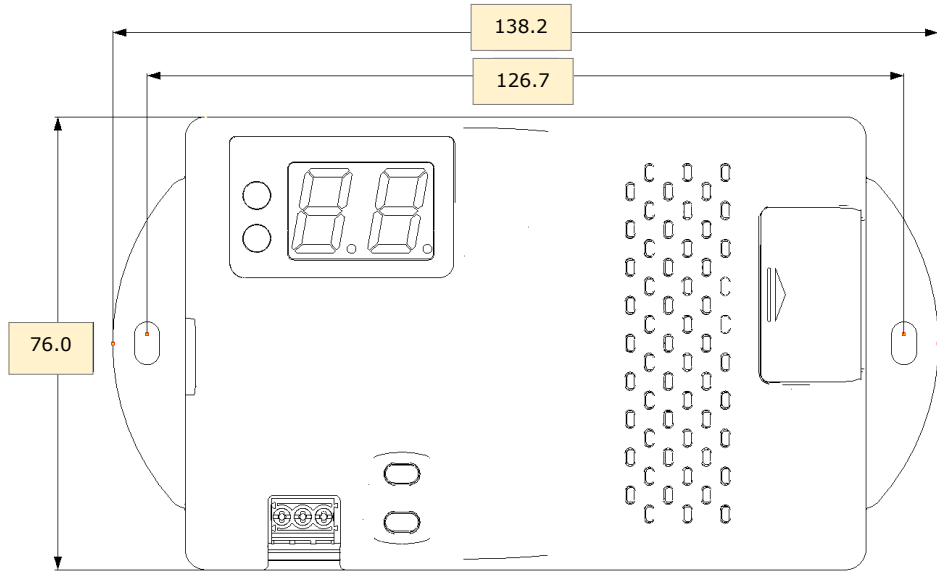
## 9 LED Display

Device Status	LED	Description
No AC Input Voltage		AC input voltage no power ON Display "- -"
50Hz AC Frequency FULL dimming		AC input frequency is 50Hz AC input voltage power ON Brightness Mode 100% Display "FU"
		AC input frequency is 50Hz AC input voltage power ON PWM Mode 100% Display "FU."
60Hz AC Frequency 80% dimming		AC input frequency is 60Hz AC input voltage power ON Brightness Mode 80% Display "80"
		AC input frequency is 60Hz AC input voltage power ON PWM Mode 80% Display "80."
Error		AC input frequency is unknown AC input voltage power ON Brightness Mode stop Display " Er"
		AC input frequency is unknown AC input voltage power ON PWM Mode stop Display "Er."

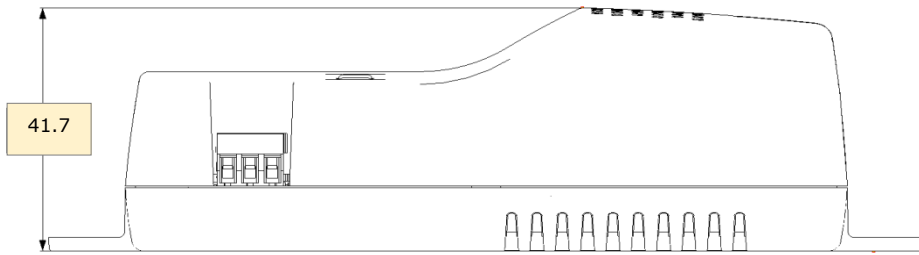
**Table 4 - LDSBus Trailing Edge Light Dimmer – LED Display**

A 7-segment LED in the controller indicates the brightness percentage when used with an external host application e.g., BRTSYS IoTPortal, LDSBus Python SDK or PanL Smart Living. The LED displays the internal PWM percentage when using the on-board buttons or external dimming interface. When an application sets the brightness, the display returns to brightness percentage.

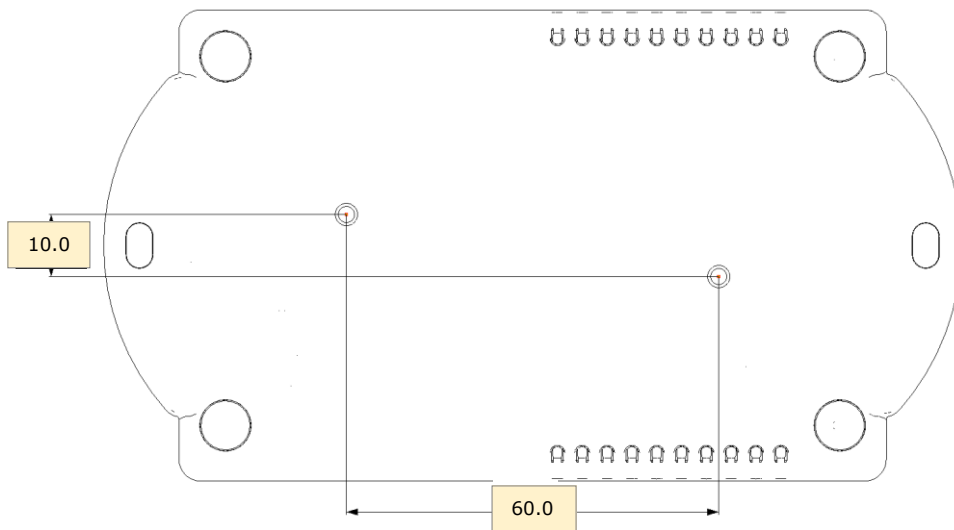
**10 Mechanical Dimension**



**Figure 9 - LDSBus Trailing Edge Light Dimmer Dimension – Top View**



**Figure 10 - LDSBus Trailing Edge Light Dimmer Dimension – Side View**



**Figure 11 - LDSBus Trailing Edge Light Dimmer Dimension – Bottom View**

## **11 Contact Information**

### **Head Quarters – Singapore**

BRT Systems Pte Ltd  
178 Paya Lebar Road, #07-03  
Singapore 409030  
Tel: +65 6547 4827  
Fax: +65 6841 6071

E-mail (Sales) [sales@brtsys.com](mailto:sales@brtsys.com)  
E-mail (Support) [support@brtsys.com](mailto:support@brtsys.com)

### **Web Site**

<http://brtsys.com/>

### **Distributor and Sales Representatives**

Please visit the Sales Network page of the [BRT Systems Web site](#) for the contact details of our distributor(s) and sales representative(s) in your country.

Neither the whole nor any part of the information contained in, or the product described in this manual, may be adapted, or Reproduced in any material or electronic form without the prior written consent of the copyright holder. This product and its documentation are supplied on an as-is basis and no warranty as to their suitability for any particular purpose is either made or implied. BRT Systems Pte Ltd will not accept any claim for damages howsoever arising as a result of use or failure of this product. Your statutory rights are not affected. This product or any variant of it is not intended for use in any medical appliance, device, or System in which the failure of the product might reasonably be expected to result in personal injury. This document provides preliminary information that may be subject to change without notice. No freedom to use patents or other intellectual property rights is implied by the publication of this document. BRT Systems Pte Ltd, 178 Paya Lebar Road, #07-03, Singapore 409030. Singapore Registered Company Number: 202220043R.

## **Appendix A – References**

### **Document References**

[BRTSYS\\_AN\\_001\\_LDSBus\\_Configuration\\_UTILITY\\_User\\_Guide](#)

### **Acronyms and Abbreviations**

<b>Terms</b>	<b>Description</b>
AC	Alternating Current
AWG	American Wire Gauges
DC	Direct Current
IoT	Internet of Things
LED	Light Emitting Diode
LDSBus	Long Distance Sensor Bus

## **Appendix B – List of Tables & Figures**

### **List of Tables**

Table 1 - LDSBus Trailing Edge Light Dimmer Specifications .....	4
Table 2 - AWG to use in terminal block on AC Input and Output load .....	8
Table 3 - AWG to use in terminal blocks on external Dim up/down .....	10
Table 4 - LDSBus Trailing Edge Light Dimmer – LED Display .....	12

### **List of Figures**

Figure 1 - LDSBus Trailing Edge Light Dimmer Controller .....	5
Figure 2 - LDSBus Trailing Edge Light Dimmer - Connection Diagram .....	6
Figure 3 - LDSBus Trailing Edge Light Dimmer Flush Mount .....	7
Figure 4 - LDSBus Trailing Edge Light Dimmer DIN Rail Mount .....	7
Figure 5 - Push-in Wire and Pull-out Wire .....	8
Figure 6 - 8mm to 12mm wire strip .....	8
Figure 7 - Clamping wire with screwdriver in clockwise direction .....	10
Figure 8 - 3mm to 5mm wire strip .....	10
Figure 9 - LDSBus Trailing Edge Light Dimmer Dimension – Top View .....	13
Figure 10 - LDSBus Trailing Edge Light Dimmer Dimension – Side View .....	13
Figure 11 - LDSBus Trailing Edge Light Dimmer Dimension – Bottom View .....	13



## Appendix C – Revision History

Document Title: LDSBus Trailing Edge Light Dimmer Datasheet  
Document Reference No.: BRTSYS\_000010  
Clearance No.: BRTSYS#008  
Product Page: <https://brtsys.com/ldsbus/>  
Document Feedback: [Send Feedback](#)

<b>Revision</b>	<b>Changes</b>	<b>Date</b>
Version 1.0	Initial Release	01-03-2022
Version 1.1	Updated release under BRT Systems	15-09-2022