

LDSBus Relay Datasheet



1 Introduction

LDSBus 2CH Relay and the LDSBus 2CH Relay + iSENSE incorporate 2 relay controllers that have high load current handling capacity of 16A. These relays can switch both AC and DC loads. The LDSBus 2CH Relay + iSENSE version has 2 additional current sensors which can each monitor up to 20A of current. The unique latching feature of the relays make these controllers ideal in applications where relays maintain their state through a software reset or hardware reset.

The LDSBus 2CH Relay controllers are ideal for usage in forward and reverse motor control applications, switching on and off high-power loads and additionally perform load sensing simultaneously.

1.1 Features

- 2 Channel dual coil latching SPDT Relay
- Supports up to 16A load per relay channel
- Current sense monitoring up to $\pm 20A$ (iSENSE option)
- Relays may be individually configured as Normally Open (NO), Normally Close (NC) or No Action relays
- Supports both AC (250V) and DC (300V) load switching
- Maintains relay state across power cycles
- Supports the BRTSYS LDSBus protocol. Wired data/power transmission through LDSBus HVT-Junction
- Low power consumption
- Operating temperature range : 0°C to +55°C
- Flush mount and DIN Rail mounting options
- Supported platform application: BRTSYS IoTPortal and LDSBus Python SDK (Visit <https://brtsys.com/resources>)



2 Part Numbers

Part#	Naming
LC011101A	LDSBus 2CH Relay
LC010101A	LDSBus 2CH Relay + iSENSE
LA120101A	LDSBus DIN Rail Mount Set

Table of Contents

1	Introduction	1
1.1	Features	1
2	Part Numbers	2
3	Product Specifications	4
4	Hardware Features	6
5	Relay Configuration and Installation	7
6	Mounting Options	8
6.1	Flush Mount	8
6.2	DIN Rail Mount	8
7	Terminal Wiring Instruction Relay Channel/ iSENSE Channel	9
7.1	Latch Relay (REL1-REL2) Setup	10
7.2	iSENSE (SEN1~SEN2) Setup	11
8	System Status LED Indicators	13
9	Mechanical Dimension	14
10	Contact Information	15
Appendix A	- References	16
	Document References	16
	Acronyms and Abbreviations	16
Appendix B	- List of Figures and Tables	17
	List of Figures	17
	List of Tables	17
Appendix C	- Revision History	18
	Internal Revision History	19

3 Product Specifications

Features	Interface	RS485
	System Status Indicator	1x RGB LED
	Relay Status Indicator	2x Red LEDs
	*Power/Sensing Indicator	1x Green LED
	Mounting	Flush Mount DIN-Rail Mount
Power	Input Voltage	5V DC Bus Power
	Power(Relay+ iSENSE)	Typ: 300mW Max:485mW
	Power(Relay)	Typ: 110mW Max:320mW
Relay	Number of Relay Channel	2
	Relay Type	SPDT, Dual Coil Latching
	Contact arrangement	1 form A (NO) Contact
	Rated voltage	≤ 250VAC
	Max. switching voltage	400VAC
	Rated current	16A
	Limiting continuous current	16A, UL:20A
	Mechanical endurance	>5x10 ⁶ operations
	Max. DC load breaking capacity	Refer to Figure 1
	Electrical endurance	Refer to Figure 1
Current Sense*	Number of Current Channel	2
	Type of current for monitoring	AC/DC
	Primary current (I _{pm})	-20A ~ 20A
	Measurable line frequency	50Hz/60Hz
	Resolution	0.2A
	Accuracy	Typ ±5%; For 0A ~ ±2A, Accuracy typ ±0.2A
	Current Output Quiescent (No current flowing through IP)	-120mA ~ 120mA
	Thermal Offset Drift	Max: ±120mA; Referred to TA=25°C, IP = 0A
Physical Characteristics	Color	White
	Housing	Polycarbonate
	Dimension	L138.2mm x W76.0mm x H31.9mm
Environmental Limits	Operating Temperature	0 to 55°C
	Storage Temperature	-20 to 85°C
	Ambient Relative Humidity	5 to 95% (non-condensing)
Package Contents	Device	1x LDSBus Relay module
	Installation (Optional)	1x DIN Rail Bracket set
	Wire Assembly	1x 5m RJ11 Cable
	Warranty label	1

*Only for LDSBus 2CH Relay + iSENSE (LC010101A)

Table 1 - LDSBus 2CH Relay Specifications

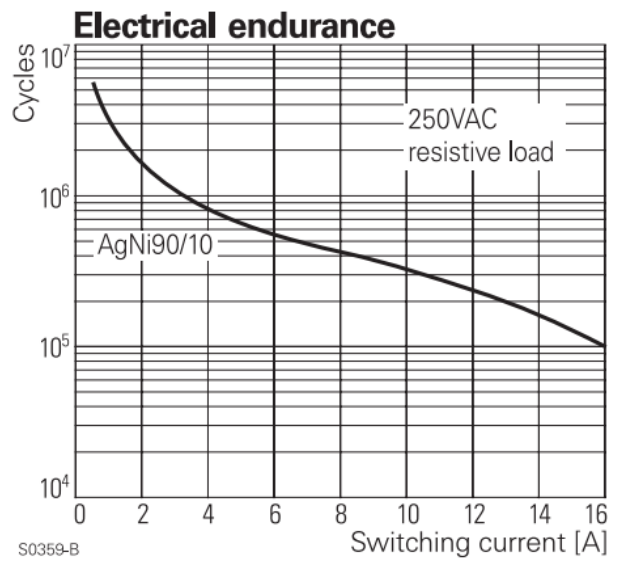
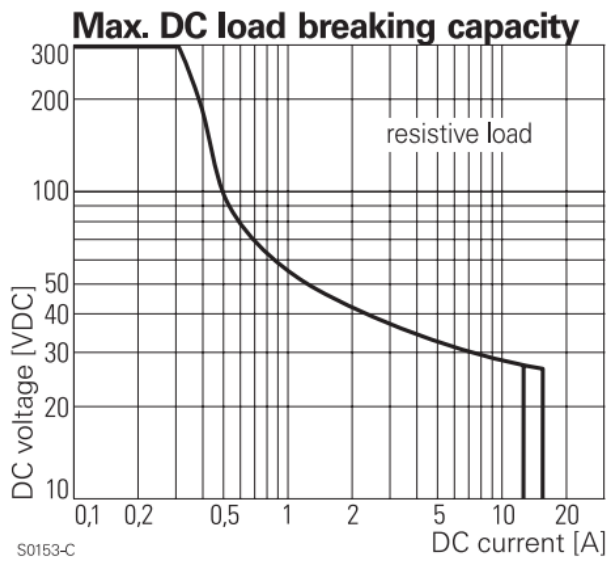
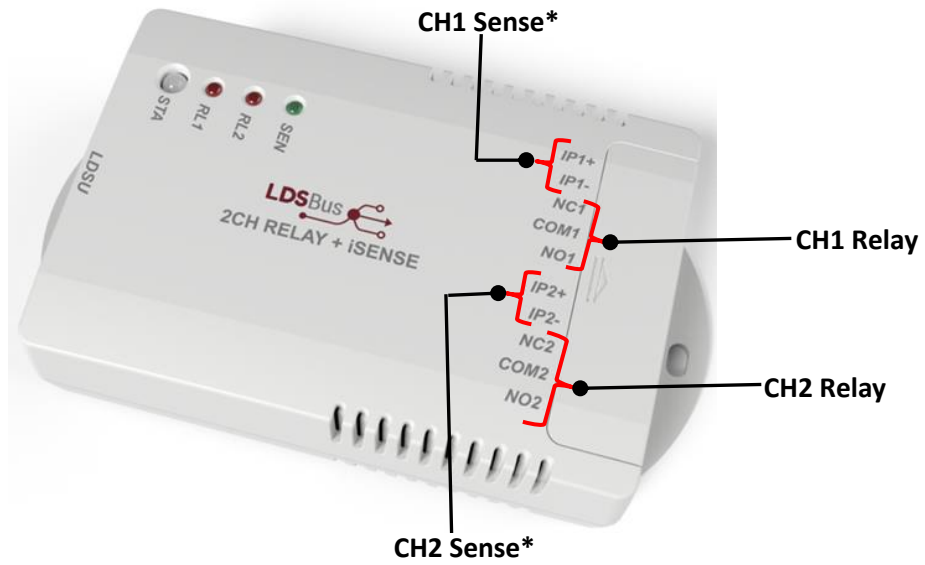

Figure 1 - Max. DC Load Breaking Capacity and Electrical Endurance

4 Hardware Features



* Applicable only for LDSBus 2CH Relay + iSENSE Model



Figure 2 - LDSBus Relay Hardware Features

5 Relay Configuration and Installation

Please visit <https://brtsys.com/resources> to access the LDSBus Configuration Utility guide on how to configure the device name, device address and termination settings before using it for your application. Normally Open (NO), Normally Close and No Action settings may be configured via the utility.

5.1 Connection Diagram

Figure 3 illustrates the connection of the LDSBus Relay (LDSBus Device) to the LDSBus. Please visit <https://brtsys.com/resources> to view the full device application, setup and installation guides.

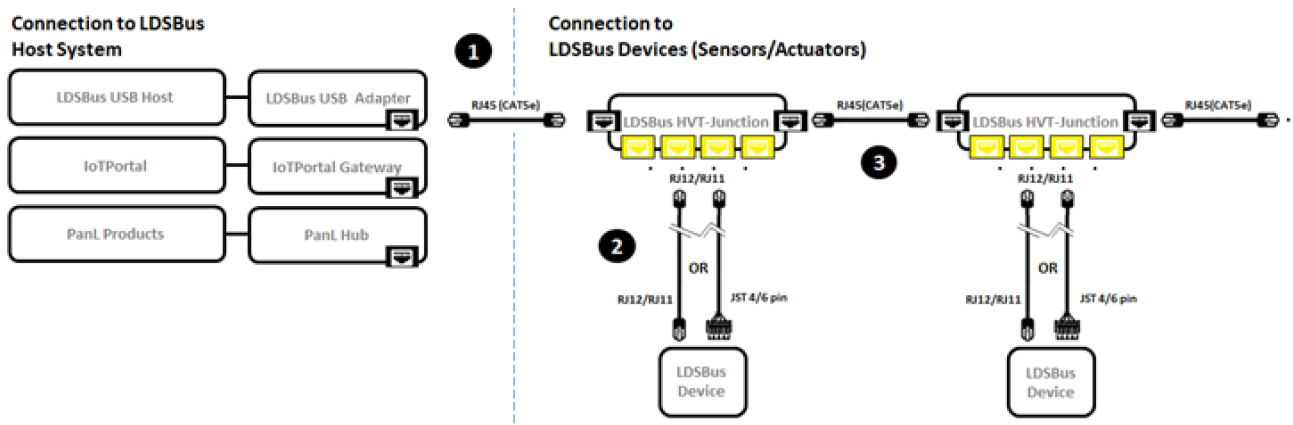

Figure 3 - LDSBus Relay - Connection Diagram

Setup Instructions:

1. Connect the first LDSBus HVT-Junction to any of the LDSBus Host System using a RJ45(CAT5e) cable.
2. Connect the configured LDSBus Relay to the LDSBus HVT-Junction as shown in Figure 3.
3. If there is more than one LDSBus HVT-Junction, chain them together as shown in Figure 3.

6 Mounting Options

6.1 Flush Mount

The LDSBus Relay can be flush mounted directly on a wall or any flat surface using 2 M3.5*16mm (thread) screws.



Figure 4 - LDSBus Relay Flush Mount

6.2 DIN Rail Mount

The LDSBus Relay can be mounted on a DIN Rail using the LDSBus DIN Rail Mount set. This set is optional and includes the bracket and mounting screws.



Figure 5 - LDSBus Relay DIN Rail Mount

7 Terminal Wiring Instruction Relay Channel/ iSENSE Channel

Connections are made with Push-in CAGE CLAMP technology. If using solid conductor wire / clamp with insulation ferrule, the stripped conductor is easily inserted into the clamp until it hits the backstop without the need for a screwdriver. In order to remove cable from connector, only use flat head screwdriver to press the push buttons and pull out the wire as shown in Figure 6.

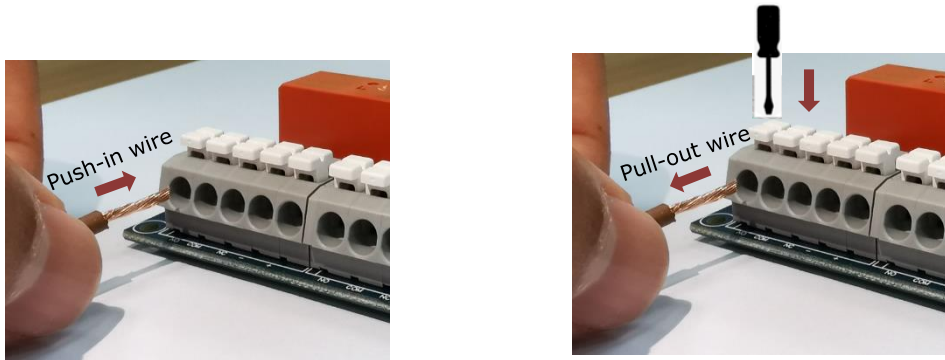

Figure 6 - Terminal Wiring on Relay Channel & iSENSE Channel (Push-in wire & Pull-out wire)

Table 2 provides a list of American Wire Gauges (AWGs) that can be used in Terminal Blocks.

Conductor Type	Wire diameter/AWG
Solid conductor	0.25~2.5mm ² /20~12 AWG
Stranded conductor	0.25~2.5mm ² /20~12 AWG
Stranded conductor; with insulated ferrule	0.25~1.5mm ²

Table 2 - AWG to use in Terminal Block

As shown in Figure 7, the wire strip is 8mm to 12mm long.

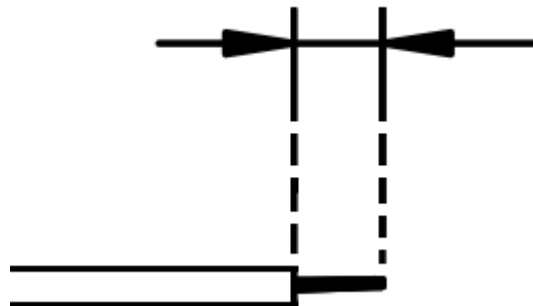
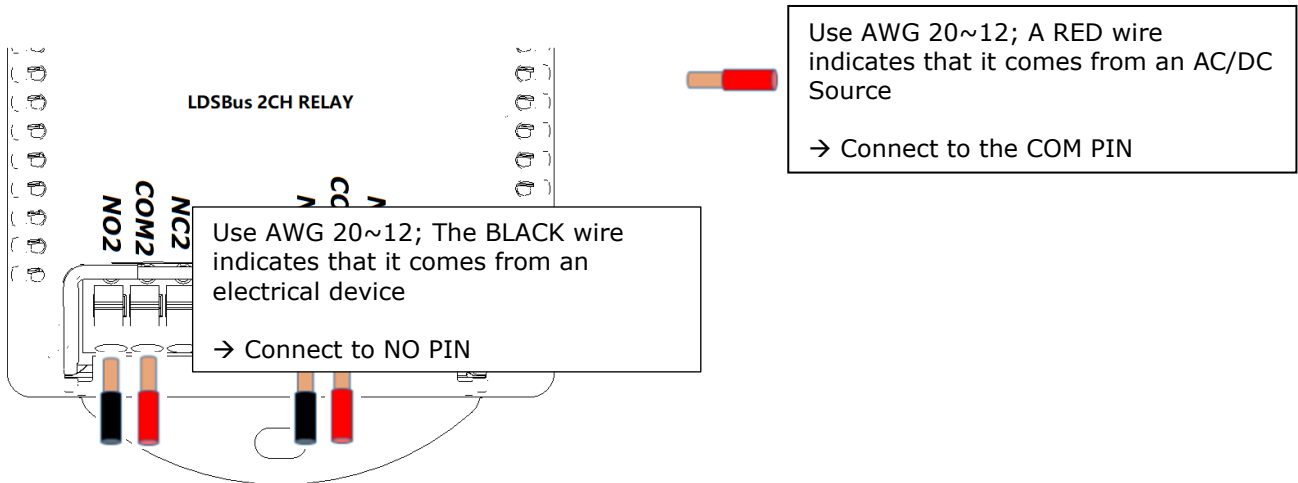

Figure 7 - Wire Strip Length

7.1 Latch Relay (REL1-REL2) Setup

The Latch Relay (REL1-REL2) support AC and DC loads and can handle 250V/16A maximum AC load per relay. The following are the two connection options:

Devices Normally OFF (NO)



Devices Normally ON (NC)

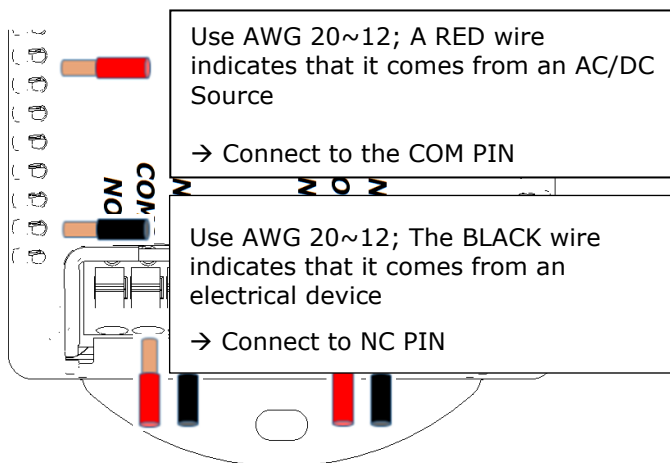

WARNING: When wiring, always TURN OFF the Power Supply.

7.2 iSENSE (SEN1~SEN2) Setup

iSENSE supports bi-directional current sense monitoring up to $-20A \sim +20A$ per channel. The following are the three connections options:

Note: Each channel is independent and so Channel 1 and Channel 2 can use a different configuration.

Standalone Sensing Monitoring

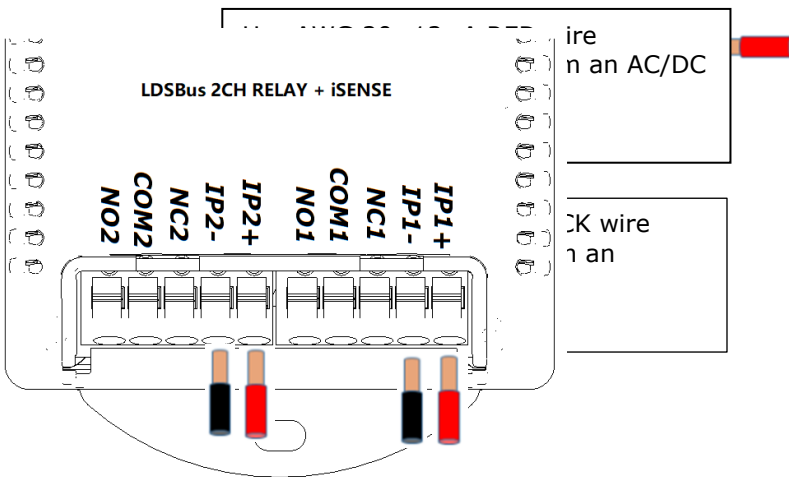

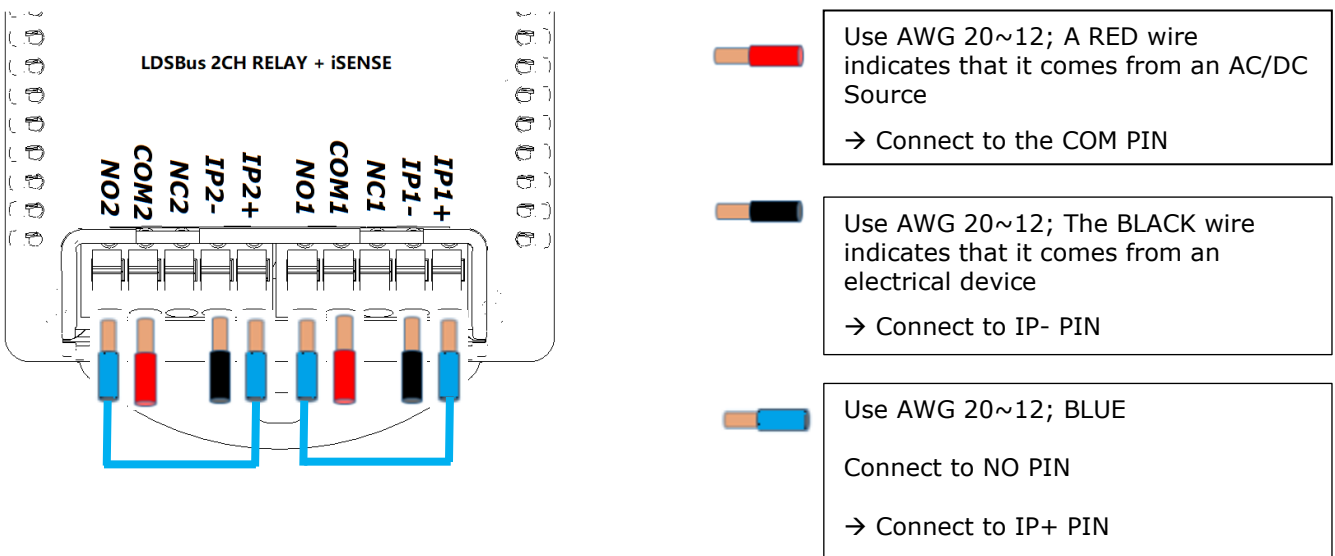

Sensing Monitoring with RELAY Devices Normally OFF (NO)

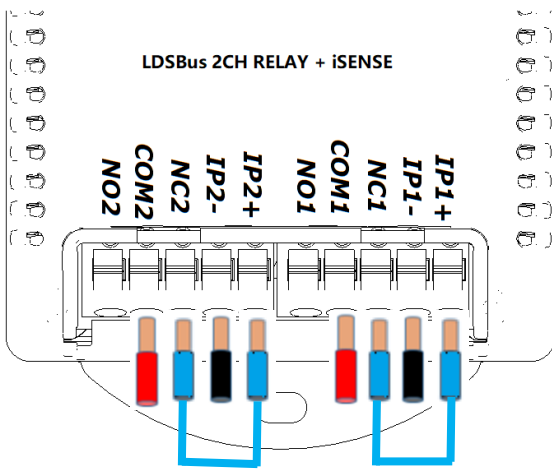

Sensing Monitoring with RELAY Devices Normally ON (NC)



- 

Use AWG 20~12; A RED wire indicates that it comes from an AC/DC Source
→ Connect to the COM PIN
- 

Use AWG 20~12; The BLACK wire indicates that it comes from an electrical device
→ Connect to IP- PIN
- 

Use AWG 20~12; BLUE
Connect to NC PIN
→ Connect to IP+ PIN

8 System Status LED Indicators

LDSU devices come with a tri-color LED, and LED status are mentioned in the table below.

Status display colors

1. RED - Device in error conditions
2. YELLOW - Unconfigured device
3. GREEN - Device in normal state (Device termination is OFF)
4. BLUE - Device in normal state (Device termination is ON)













Device Status	LED Color		Flashing Frequency	Description
Unconfigured device	YELLOW		LED flashing @1Hz	Unconfigured device with factory default address (126)
Configured device	GREEN		Steady – Non-flashing	Configured device (Device ID 1-125) and device is idle.
	BLUE			
Addressed device	GREEN		LED flashing @5Hz	Device is busy communicating.
	BLUE			
Identified device	GREEN		LED flashing @1Hz	Device in identify state.
	BLUE			
Device error	RED		Steady – Non-flashing	Device error has occurred.
Firmware update	YELLOW		Steady – Non-flashing	Device firmware update.
Relay 1 and Relay 2	Red		Steady – Non-flashing	Relay in operate
	Off		LED Off	Relay in Reset
PWR/Sen	Green		Steady – Non-flashing	Power is on/iSENSE is on

Table 3 - LDSBus Relay – System Status LED Indicator

9 Mechanical Dimension

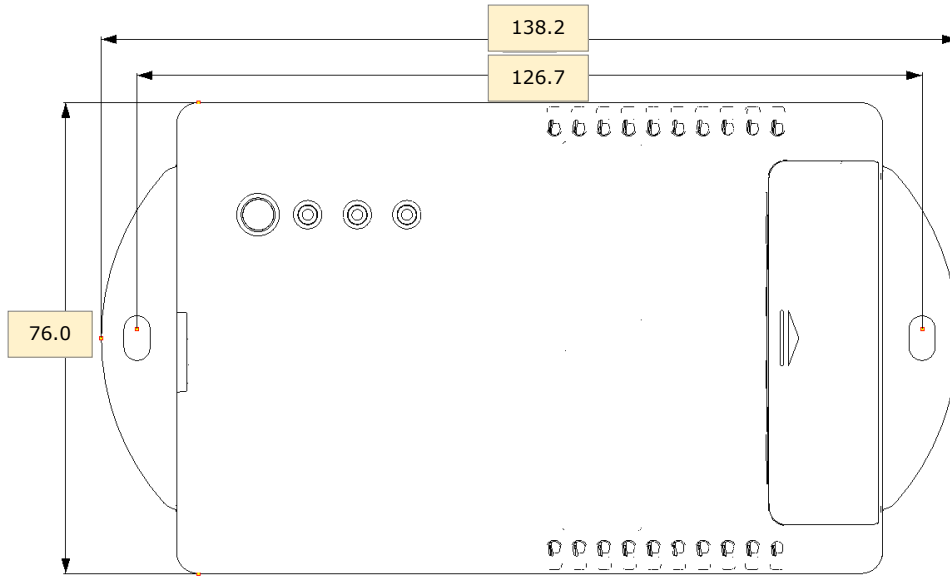

Figure 8 - LDSBus Relay Dimension - Top View

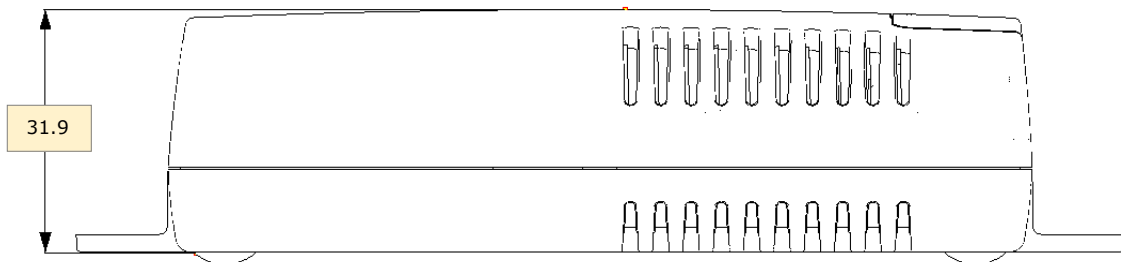

Figure 9 - LDSBus Relay Dimension - Side View

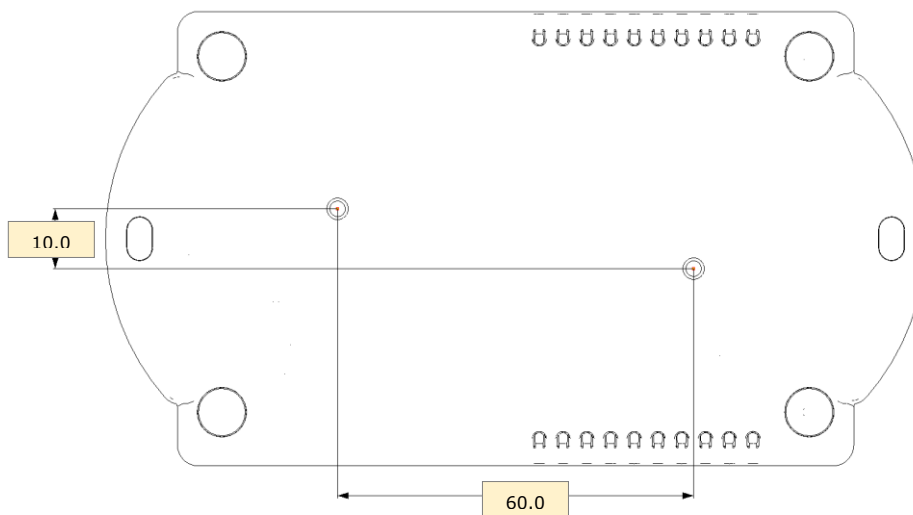

Figure 10 - LDSBus Relay Dimension - Bottom View

Note: All dimensions are in millimetres.

10 Contact Information

Head Quarters – Singapore

BRT Systems Pte Ltd
178 Paya Lebar Road, #07-03
Singapore 409030
Tel: +65 6547 4827
Fax: +65 6841 6071

E-mail (Sales) sales@brtsys.com
E-mail (Support) support@brtsys.com

Web Site

<http://brtsys.com/>

Distributor and Sales Representatives

Please visit the Sales Network page of the [BRT Systems Web Site](#) for the contact details of our distributor(s) and sales representative(s) in your country.

System and equipment manufacturers and designers are responsible to ensure that their systems, and any BRT Systems Pte Ltd (BRTSYS) devices incorporated in their systems, meet all applicable safety, regulatory and system-level performance requirements. All application-related information in this document (including application descriptions, suggested BRT Systems devices and other materials) is provided for reference only. While BRT Systems has taken care to assure it is accurate, this information is subject to customer confirmation, and BRT Systems disclaims all liability for system designs and for any applications assistance provided by BRT Systems. Use of BRT Systems devices in life support and/or safety applications is entirely at the user's risk, and the user agrees to defend, indemnify, and hold harmless BRT Systems from any and all damages, claims, suits, or expense resulting from such use. This document is subject to change without notice. No freedom to use patents or other intellectual property rights is implied by the publication of this document. Neither the whole nor any part of the information contained in, or the product described in this document, may be adapted, or reproduced in any material or electronic form without the prior written consent of the copyright holder. BRT Systems Pte Ltd, 178 Paya Lebar Road, #07-03, Singapore 409030. Singapore Registered Company Number: 202220043R.

Appendix A - References

Document References

[BRTSYS AN 001 LDSBus Configuration Utility User Guide](#)

Acronyms and Abbreviations

Terms	Description
AC	Alternating Current
AWG	American Wire Gauges
DC	Direct Current
IoT	Internet of Things
LED	Light Emitting Diode
LDSBus	Long Distance Sensor Bus

Appendix B - List of Figures and Tables

List of Figures

Figure 1 - Max. DC Load Breaking Capacity and Electrical Endurance.....	5
Figure 2 - LDSBus Relay Hardware Features.....	6
Figure 3 - LDSBus Relay - Connection Diagram	7
Figure 4 - LDSBus Relay Flush Mount	8
Figure 5 - LDSBus Relay DIN Rail Mount	8
Figure 6 - Terminal Wiring on Relay Channel & iSENSE Channel (Push-in wire & Pull-out wire)	9
Figure 7 - Wire Strip Length	9
Figure 8 - LDSBus Relay Dimension – Top View	14
Figure 9 - LDSBus Relay Dimension – Side View	14
Figure 10 - LDSBus Relay Dimension – Bottom View	14

List of Tables

Table 1 - LDSBus 2CH Relay Specifications	4
Table 2 - AWG to use in Terminal Block	9
Table 3 - LDSBus Relay – System Status LED Indicator	13

Appendix C – Revision History

Document Title: LDSBus Relay Datasheet
Document Reference No.: BRTSYS_000008
Clearance No.: BRTSYS#007
Product Page: <https://brtsys.com/ldsbus/>
Document Feedback: [Send Feedback](#)

Revision	Changes	Date
Version 1.0	Initial Release	06-12-2021
Version 1.1	Updated release under BRT Systems	15-09-2022