



# LDSBus Isolated IO Controller Datasheet



## 1 Introduction

The LDSBus Isolated IO Controller offers 2 isolated channels of digital and analog inputs and a variety of associated power source options to achieve 3.3V, 5V, 10V, 12V referenced signals besides sourcing power from external voltage sources. Each channel (input and output) is isolated from the others.

Each digital output can switch between 0V and 3.3V, 5V, 12V or referenced to an external voltage source. Each digital input can be between 0V and 1.8V to 12V. A 5V voltage source is provided for common applications that switch between 0-5V.

Each analog output can produce a voltage between 0-10V, and each analog input supports voltage or current controlled input sources ranging between 0-10V.

The controller may be used in numerous and diverse applications such as simple IO control, or 0-10V dimmers, weather station, water level detector or sensor, etc.

## 1.1 Features

- 2 isolated digital output channels
- 2 isolated digital input channels
- 2 isolated analog output channels
- 2 isolated analog input channels
- Built-in power supply (3.3V/ 5V/ 10V/ 12V) and external power supply option
- Flexible combination of internal or external power supply
- Supports BRTSYS LDSBus protocol
- Low power consumption
- Operating temperature range : 0°C to +55°C
- Flush mount and DIN Rail mounting options
- Supported platforms: LDSBus Host, BRTSYS IoTPortal, and PanL Smart Living products. Visit <https://brtsys.com/resources> for more information



Neither the whole nor any part of the information contained in, or the product described in this manual, may be adapted, or Reproduced in any material or electronic form without the prior written consent of the copyright holder. This product and its documentation are supplied on an as-is basis and no warranty as to their suitability for any particular purpose is either made or implied. BRT Systems Pte Ltd will not accept any claim for damages howsoever arising as a result of use or failure of this product. Your statutory rights are not affected. This product or any variant of it is not intended for use in any medical appliance, device, or System in which the failure of the product might reasonably be expected to result in personal injury. This document provides preliminary information that may be subject to change without notice. No freedom to use patents or other intellectual property rights is implied by the publication of this document. BRT Systems Pte Ltd, 178 Paya Lebar Road, #07-03, Singapore 409030. Singapore Registered Company Number: 202220043R.

## 2 Part Numbers

Part#	Naming
LC060101A	LDSBus Isolated IO Controller
LA120101A	LDSBus DIN Rail Mount Set

## Table of Contents

<b>1</b>	<b>Introduction .....</b>	<b>1</b>
1.1	Features .....	1
<b>2</b>	<b>Part Numbers .....</b>	<b>2</b>
<b>3</b>	<b>Product Specifications .....</b>	<b>4</b>
<b>4</b>	<b>Hardware Features .....</b>	<b>5</b>
<b>5</b>	<b>Isolated IO Controller Configuration and Installation</b>	<b>6</b>
<b>6</b>	<b>Mounting Options .....</b>	<b>7</b>
6.1	Flush Mount.....	7
6.2	DIN Rail Mount.....	7
<b>7</b>	<b>Terminal Wiring Instructions.....</b>	<b>8</b>
7.1	Isolated IO Digital INPUT Setup.....	9
7.2	Isolated IO Digital OUTPUT Setup .....	10
7.3	Isolated Analog INPUT Setup .....	11
7.4	Isolated Analog OUTPUT Setup .....	12
<b>8</b>	<b>System Status LED Indicators.....</b>	<b>13</b>
<b>9</b>	<b>Mechanical Dimension .....</b>	<b>14</b>
<b>10</b>	<b>Contact Information .....</b>	<b>15</b>
<b>Appendix A – References .....</b>	<b>16</b>	
Document References .....	16	
Acronyms and Abbreviations.....	16	
<b>Appendix B – List of Tables &amp; Figures .....</b>	<b>17</b>	
List of Tables.....	17	
List of Figures .....	17	
<b>Appendix C – Revision History .....</b>	<b>18</b>	

### 3 Product Specifications

<b>Features</b>	Interface	RS485
	System Status Indicator	1x RGB LED
	Mounting	Flush Mount DIN-Rail Mount
<b>Power</b>	Input Voltage	5V DC Bus Power
	Power (Typ)	1.15W
	Power (Max)	1.20W
	Output Power*	3.3V/30mW
		5V/50mW
10V/400mW		
12V/240mW		
<b>Analog Input</b>	Number of Channels	2
	Analog Input range	0V - 10V
	Analog Input resolution	10mV
	Analog Input Accuracy	Typical: +/- 3%; For 0V - 1V, Accuracy: +/- 10mV (typical)
<b>Analog Output</b>	Number of Channels	2
	Analog Output range	0V - 10V
	Analog Output resolution	10mV
	Analog Output Accuracy	Typical: +/- 3%; For 0V - 1V, Accuracy: +/- 10mV (typical)
<b>Digital IO Input</b>	Number of Channels	2
	Digital Input Voltage	1.8VDC - 12VDC (refer to external power voltage)
<b>Digital IO Output</b>	Number of Channels	2
	Digital Output Voltage	1.8VDC - 12VDC (refer to external power voltage)
<b>Physical Characteristics</b>	Color	White
	Housing	Polycarbonate
	Dimension	L138.2mm x W76.0mm x H31.9mm
<b>Environmental Limits</b>	Operating Temperature	0 to 55°C
	Storage Temperature	-20 to 85°C
	Ambient Relative Humidity	5 to 95% (non-condensing)
<b>Package Contents</b>	Device	1x LDSBus Isolated IO Controller
	Installation (Optional)	1x Din Rail Bracket set
	Wire Assembly	1X 5m RJ12 Cable
	Warranty label	1

\* Output power current output up to 60mA.

**Table 1 - LDSBus Isolated IO Controller Specifications**

## 4 Hardware Features

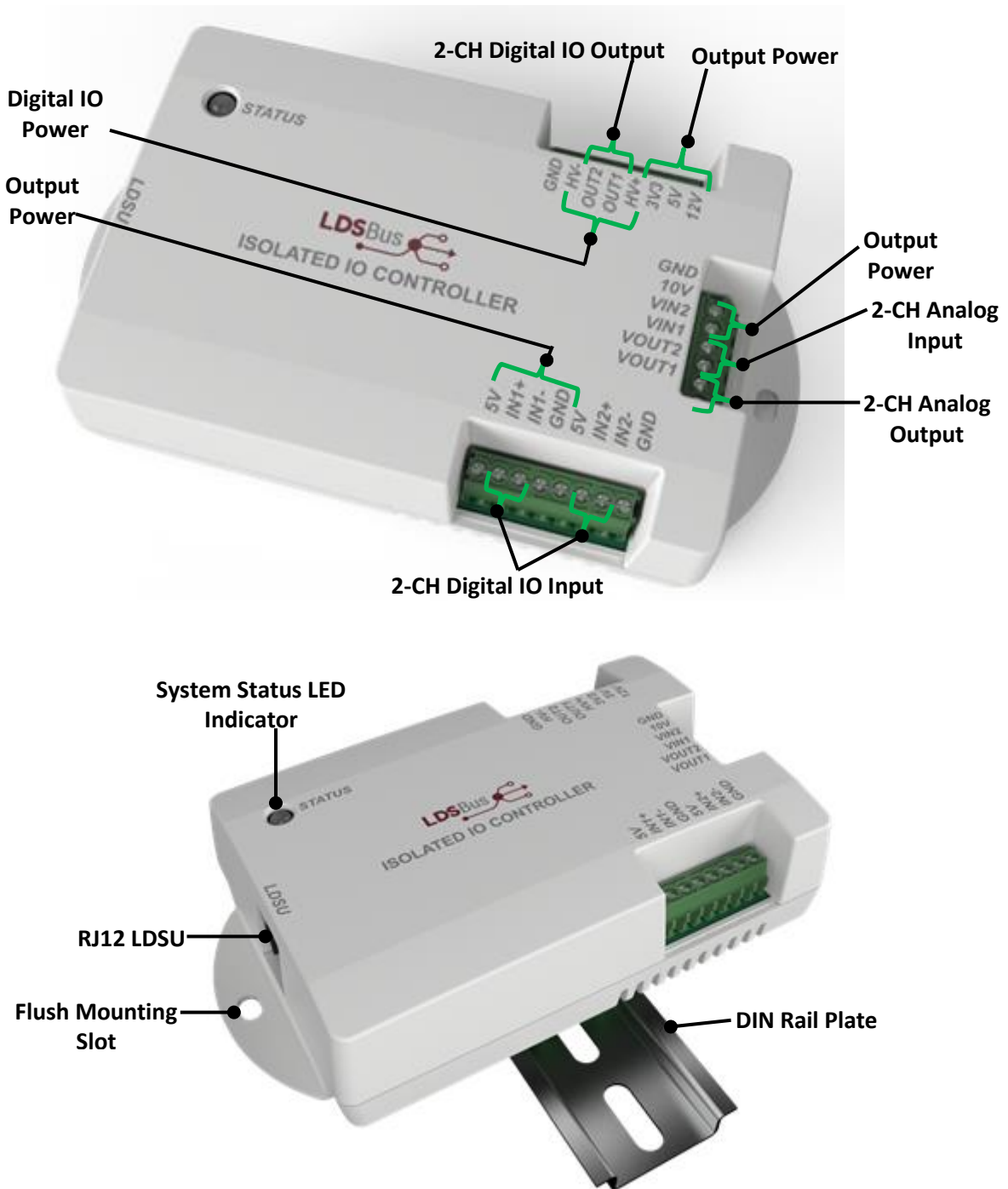

**Figure 1 - LDSBus Isolated IO Controller**

## 5 Isolated IO Controller Configuration and Installation

Please visit <https://brtsys.com/resources> to access the LDSBus Configuration Utility guide on how to configure the device name, device address and termination settings before using it in your application.

### 5.1 Connection Diagram

Figure 2 illustrates the connection of the LDSBus Isolated IO Controller (LDSBus Device) to the LDSBus. Please visit <https://brtsys.com/resources> to view the full device application, setup and installation guides.

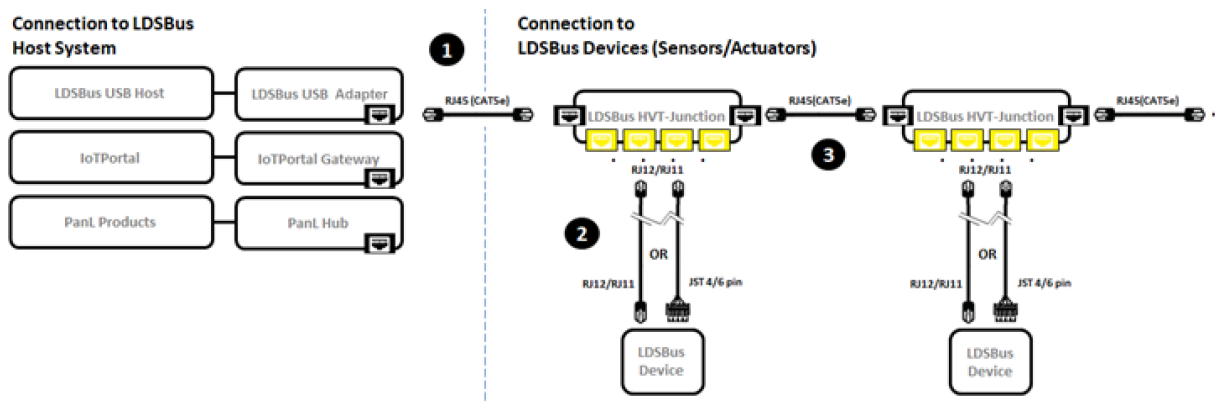

**Figure 2 - LDSBus Isolated IO controller - Connection Diagram**

#### **Setup Instructions:**

1. Connect the first LDSBus HVT-Junction to any of the LDSBus Host Systems using a RJ45(CAT5e) cable.
2. Connect the configured LDSBus Isolated IO controller to the LDSBus HVT-Junction as shown in Figure 2.
3. If there is more than one LDSBus HVT-Junction, chain them together as shown in Figure 2.
4. Enable terminator on the last device in LDSBus.

## 6 Mounting Options

### 6.1 Flush Mount

The LDSBus Isolated IO Controller can be flush mounted directly on a wall or any flat surface using 2 M3.5\*16mm (thread) screws.



**Figure 3 - LDSBus Isolated IO Controller Flush Mount**

### 6.2 DIN Rail Mount

The LDSBus Isolated IO Controller can be mounted on a DIN Rail using the LDSBus DIN Rail Mount set. This set is optional and includes the bracket and mounting screws.



**Figure 4 - LDSBus Isolated IO Controller DIN Rail Mount**

## 7 Terminal Wiring Instructions

Terminal blocks are connected with screws. To clamp the wire to the terminal block, insert a 0.4mm x 2.5mm slotted screwdriver and rotate in a clockwise direction. To release the wire, turn the handle in an anticlockwise direction.



**Figure 5 - Clamping wire with screwdriver in clockwise direction**

Table 2 provides a list of American Wire Gauges (AWGs) that can be used in Terminal Blocks.

Conductor Type	Wire diameter / AWG
Solid conductor	0.2~1.5mm <sup>2</sup> /26~16 AWG
Stranded conductor	0.2~1.5mm <sup>2</sup> /26~16 AWG
Stranded conductor; with insulated ferrule	0.25~0.75mm <sup>2</sup>

**Table 2 - AWG to use in terminal block**

As shown in Figure 6, the wire strip is 3mm to 5mm long.

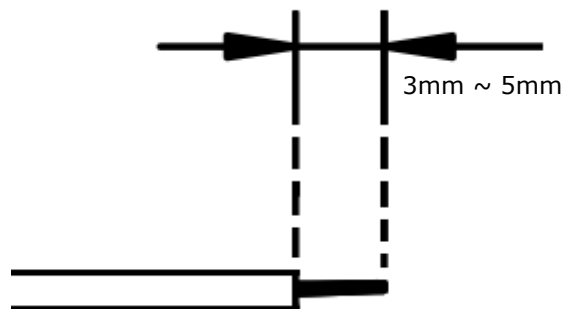

**Figure 6 - 3mm to 5mm wire strip**



## 7.1 Isolated IO Digital INPUT Setup

The 2CH isolated digital input supports external digital signals ranging from 1.8 to 12V. The two options for connecting are as follows:

**Note:** As each channel is independent, Channel 1 and Channel 2 can use different configurations.

### IO Digital Input with 5V Application

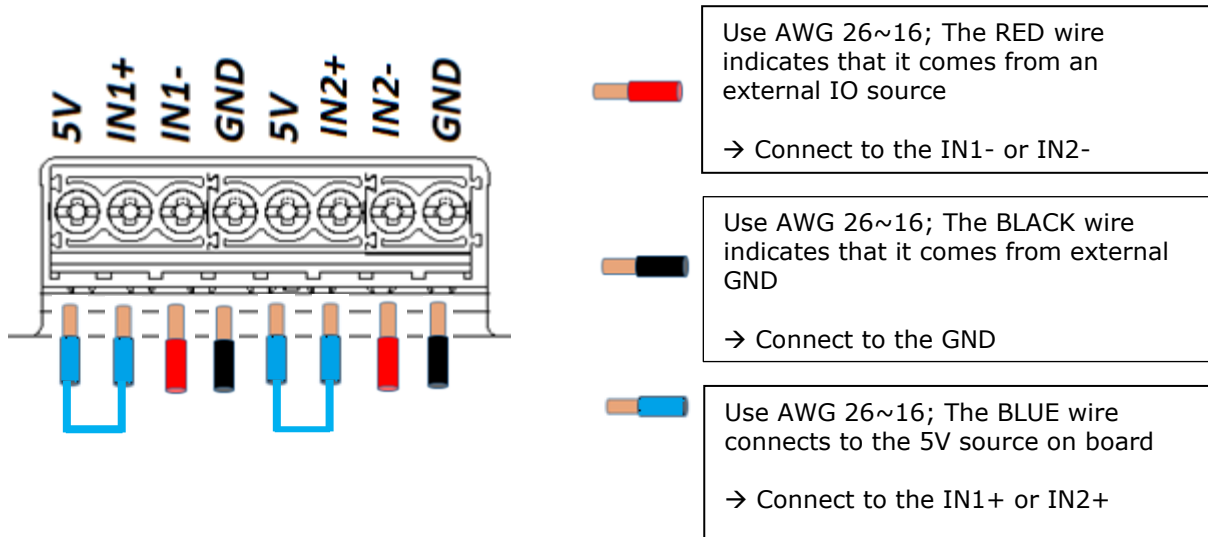

### IO Digital Input with External Pull-up

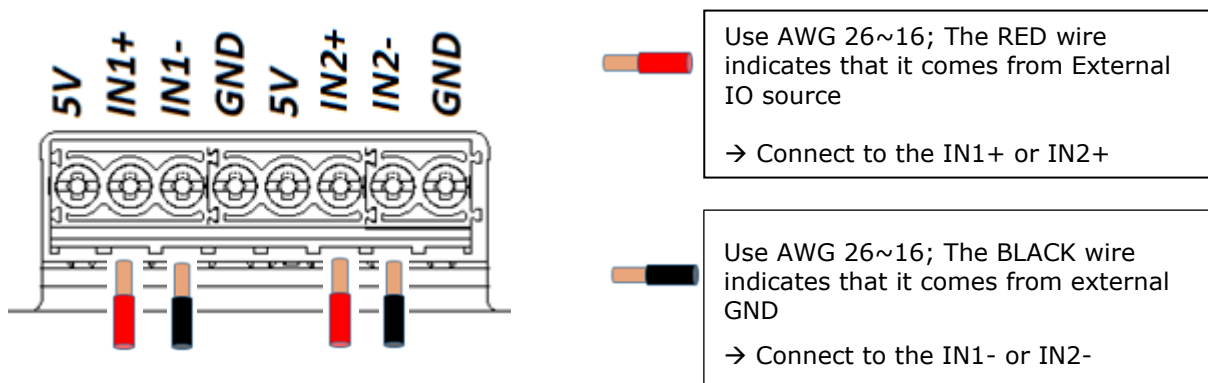

## 7.2 Isolated IO Digital OUTPUT Setup

The 2CH isolated digital output supports external digital signals ranging from 1.8 to 12V. The two options for connecting are as follows:

### Digital Output with 5V Application

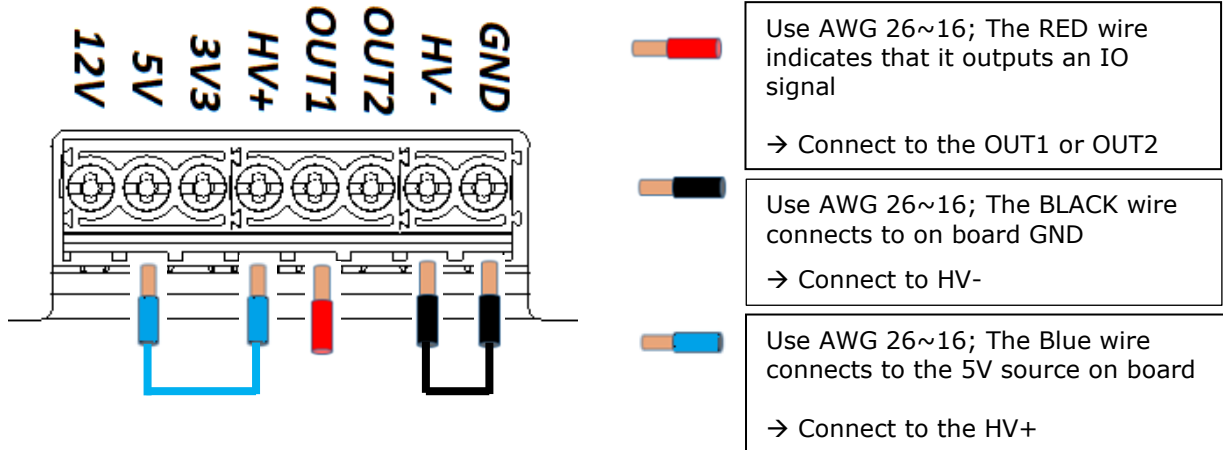

### Digital Output with External Source

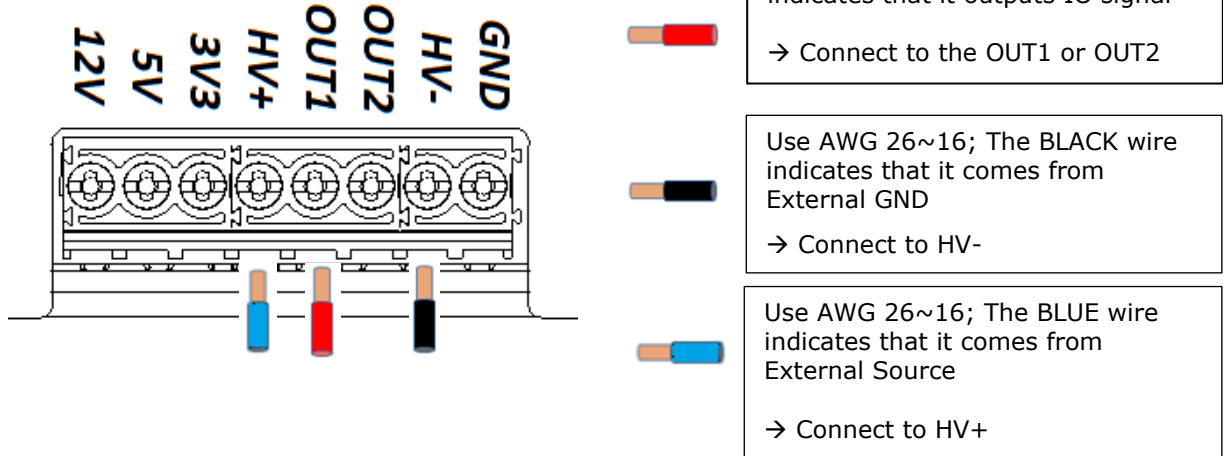

### 7.3 Isolated Analog INPUT Setup

The 2CH isolated analog input supports external analog signals ranging from 0 to 10V. The two options for connecting are as follows:

#### Analog Input with External Voltage Source

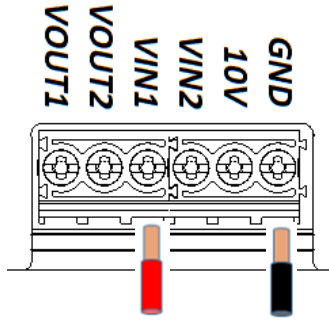

Use AWG 26~16; The RED wire indicates that it comes from external voltage source  
→ Connect to VIN1 or VIN2

Use AWG 26~16; The BLACK wire indicates that it comes from external GND  
→ Connect to GND

#### Analog Input with External Current Source

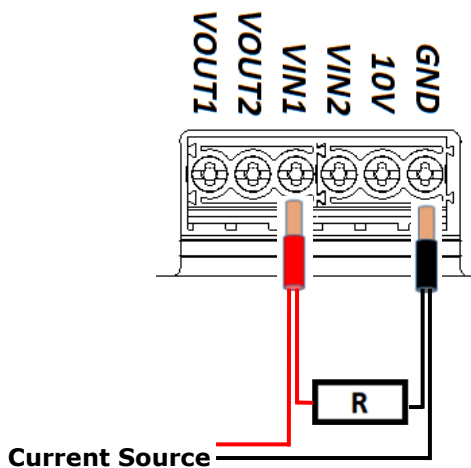

Use AWG 26~16; The RED wire indicates that it comes from external current source  
→ Connect to VIN1 or VIN2

Use AWG 26~16; The BLACK wire indicates that it comes from external GND  
→ Connect to GND

Serial Resistor value depends on current source  
→ Connect in between VIN1/VIN2 and GND  
  
For example: Application current source 4mA to 20mA, recommend using 450ohm resistor

## 7.4 Isolated Analog OUTPUT Setup

The 2CH isolated analog output supports external analog signals ranging from 0 to 10V. The two options for connecting are as follows:

### Analog Voltage Output

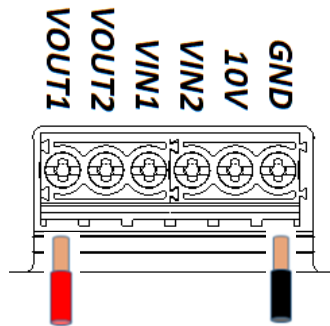

Use AWG 26~16; The RED wire indicates that it outputs 0V - 10V power

→ Connect to VOUT1 or VOUT2



Use AWG 26~16; The BLACK wire indicates that it comes external GND









→ Connect to GND

## 8 System Status LED Indicators

LDSU devices come with a tri-color LED, and LED status are mentioned in the table below.

Status display colors

- 1. RED - Device in error conditions
- 2. YELLOW - Unconfigured device
- 3. GREEN - Device in normal state (Device termination is OFF)
- 4. BLUE - Device in normal state (Device termination is ON)

Device Status	LED Color		Flashing Frequency	Description
Unconfigured device	YELLOW		LED flashing @1Hz	Unconfigured device with factory default address (126)
Configured device	GREEN		Steady – Non-flashing	Configured device (Device ID 1-125) and device is idle
	BLUE			
Addressed device	GREEN		LED flashing @5Hz	Device is busy communicating
	BLUE			
Identified device	GREEN		LED flashing @1Hz	Device in identify state
	BLUE			
Device error	RED		Steady – Non-flashing	Device error has occurred
Firmware update	YELLOW		Steady – Non-flashing	Device firmware update

**Table 3 - LDSBus Isolated IO Controller – System Status LED Indicator**

## 9 Mechanical Dimension

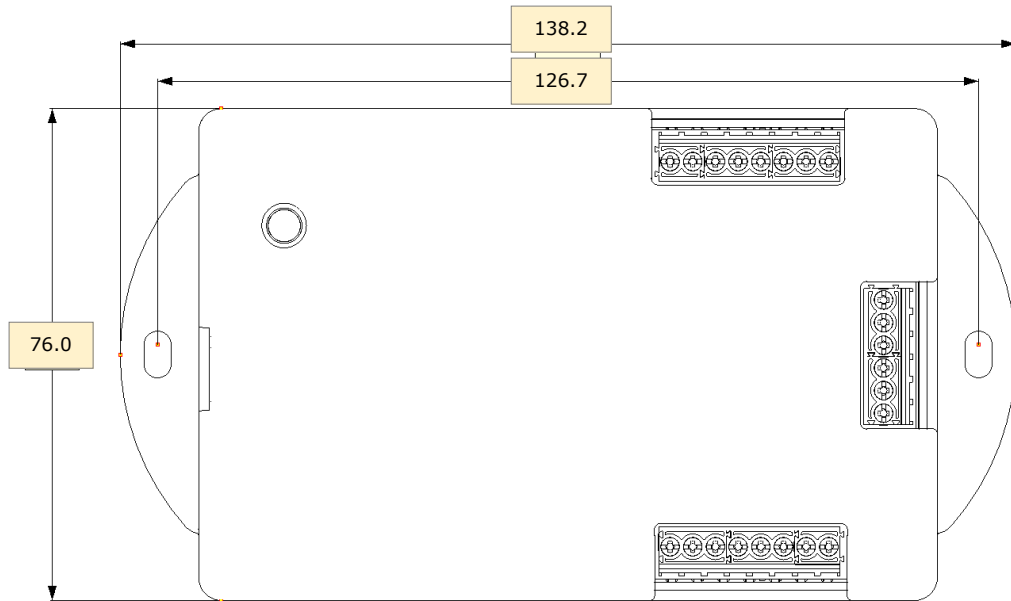

**Figure 7 - LDSBus Isolated IO Controller Dimension – Top View**

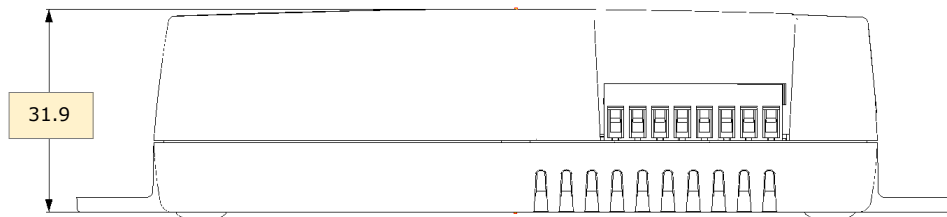

**Figure 8 - LDSBus Isolated IO Controller Dimension – Side View**

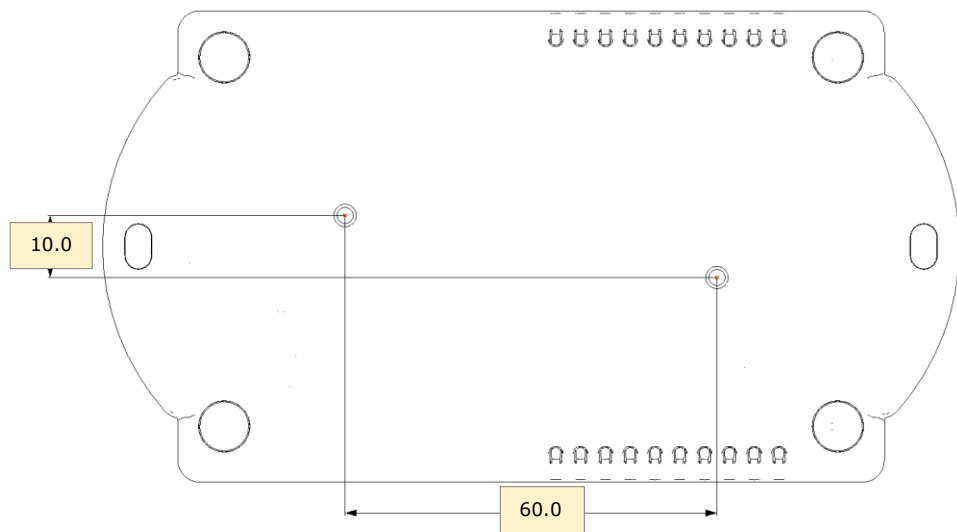

**Figure 9 - LDSBus Isolated IO Controller Dimension – Bottom View**

## 10 Contact Information

### Head Quarters – Singapore

BRT Systems Pte Ltd  
178 Paya Lebar Road, #07-03  
Singapore 409030  
Tel: +65 6547 4827  
Fax: +65 6841 6071

E-mail (Sales) [sales@brtsys.com](mailto:sales@brtsys.com)  
E-mail (Support) [support@brtsys.com](mailto:support@brtsys.com)

### Web Site

<http://brtsys.com/>

### Distributor and Sales Representatives

Please visit the Sales Network page of the [BRT Systems Web site](#) for the contact details of our distributor(s) and sales representative(s) in your country.

System and equipment manufacturers and designers are responsible to ensure that their systems, and any BRT Systems Pte Ltd (BRTSYS) devices incorporated in their systems, meet all applicable safety, regulatory and system-level performance requirements. All application-related information in this document (including application descriptions, suggested BRT Systems devices and other materials) is provided for reference only. While BRT Systems has taken care to assure it is accurate, this information is subject to customer confirmation, and BRT Systems disclaims all liability for system designs and for any applications assistance provided by BRT Systems. Use of BRT Systems devices in life support and/or safety applications is entirely at the user's risk, and the user agrees to defend, indemnify, and hold harmless BRT Systems from any and all damages, claims, suits, or expense resulting from such use. This document is subject to change without notice. No freedom to use patents or other intellectual property rights is implied by the publication of this document. Neither the whole nor any part of the information contained in, or the product described in this document, may be adapted, or reproduced in any material or electronic form without the prior written consent of the copyright holder. BRT Systems Pte Ltd, 178 Paya Lebar Road, #07-03, Singapore 409030. Singapore Registered Company Number: 202220043R.

## Appendix A – References

### Document References

[BRTSYS AN 001 LDSBus Configuration Utility User Guide](#)

### Acronyms and Abbreviations

Terms	Description
AC	Alternating Current
AWG	American Wire Gauges
DC	Direct Current
IoT	Internet of Things
LED	Light Emitting Diode
LDSBus	Long Distance Sensor Bus



## **Appendix B – List of Tables & Figures**

### **List of Tables**

Table 1 - LDSBus Isolated IO Controller Specifications .....	4
Table 2 - AWG to use in terminal block .....	8
Table 3 - LDSBus Isolated IO Controller – System Status LED Indicator .....	13

### **List of Figures**

Figure 1 - LDSBus Isolated IO Controller.....	5
Figure 2 - LDSBus Isolated IO controller - Connection Diagram.....	6
Figure 3 - LDSBus Isolated IO Controller Flush Mount .....	7
Figure 4 - LDSBus Isolated IO Controller DIN Rail Mount.....	7
Figure 5 - Clamping wire with screwdriver in clockwise direction .....	8
Figure 6 - 3mm to 5mm wire strip.....	8
Figure 7 - LDSBus Isolated IO Controller Dimension – Top View.....	14
Figure 8 - LDSBus Isolated IO Controller Dimension – Side View.....	14
Figure 9 - LDSBus Isolated IO Controller Dimension – Bottom View.....	14

## Appendix C – Revision History

Document Title: LDSBus Isolated IO Controller Datasheet  
Document Reference No.: BRTSYS\_000009  
Clearance No.: BRTSYS#005  
Product Page: <https://brtsys.com/ldsbus/>  
Document Feedback: [Send Feedback](#)

Revision	Changes	Date
Version 1.0	Initial Release	15-02-2022
Version 1.1	Updated release under BRT Systems	15-09-2022