

1/4" BSP
Load Sensing Port

1/4" BSP
Control Drain Port

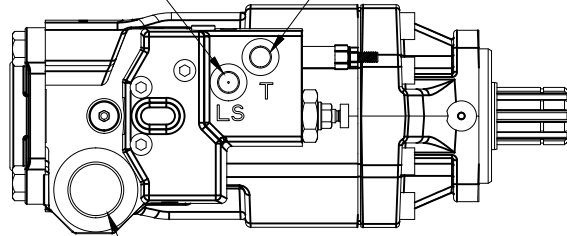

1" BSP Pressure Port
(R.H. Rotation)

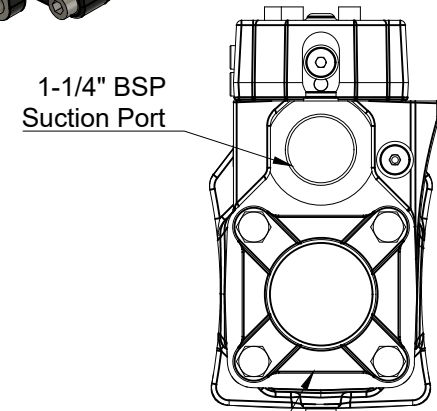
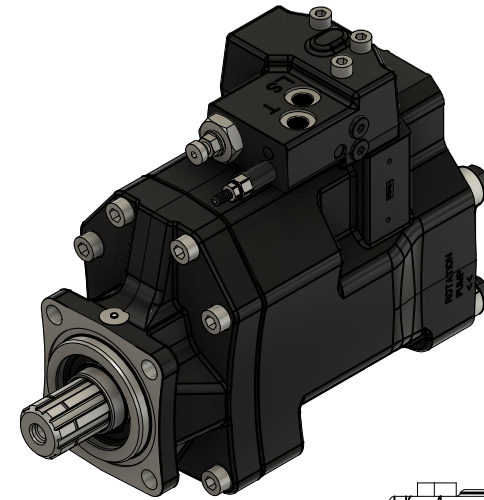
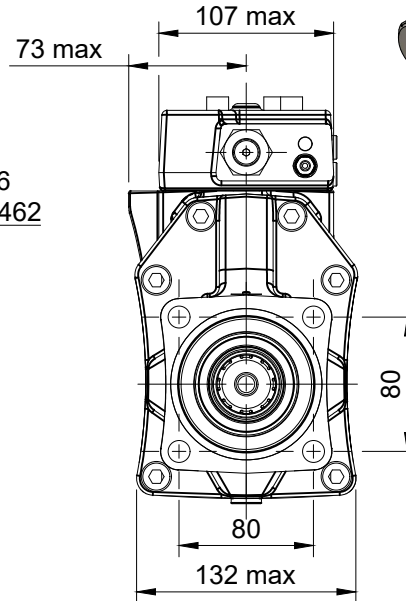
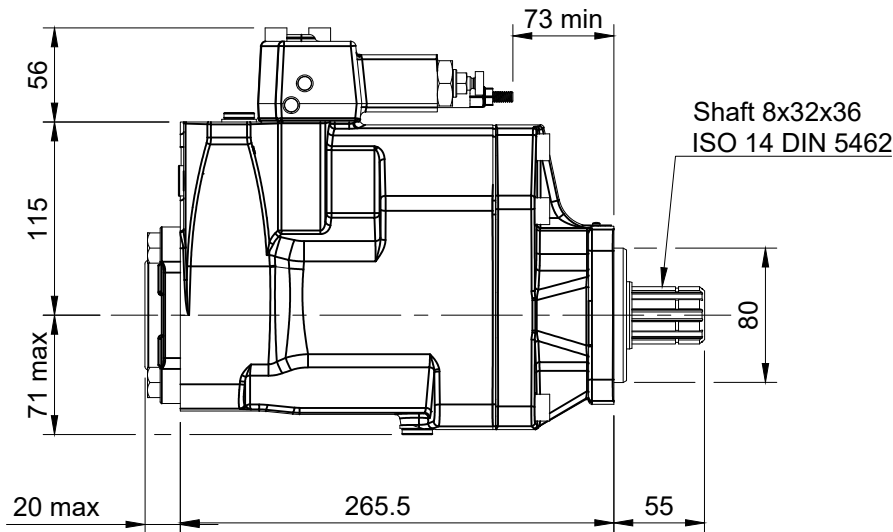

Auxiliary Pump Cover

PMP-PVP1-075-*S *Rotation D=Clockwise S=Anti-Clockwise



Pump Type		VP1 075
Displacement	cm ³ /rev	075
Max Operating Pressure	Bar	350 Continuous
Max Continuous Speed	RPM	1700 2" Suction Line, Max
Weight (with control)	Kg	27

20/01/2023

Recommended Filtration

10µm (absolute) in contaminated environment or at high pressures.

25µm (absolute) in clean environment or at low pressures.