

Note:
Air inlet port requires a tee connection coming from the pneumatic down function block of the hydraulic valve

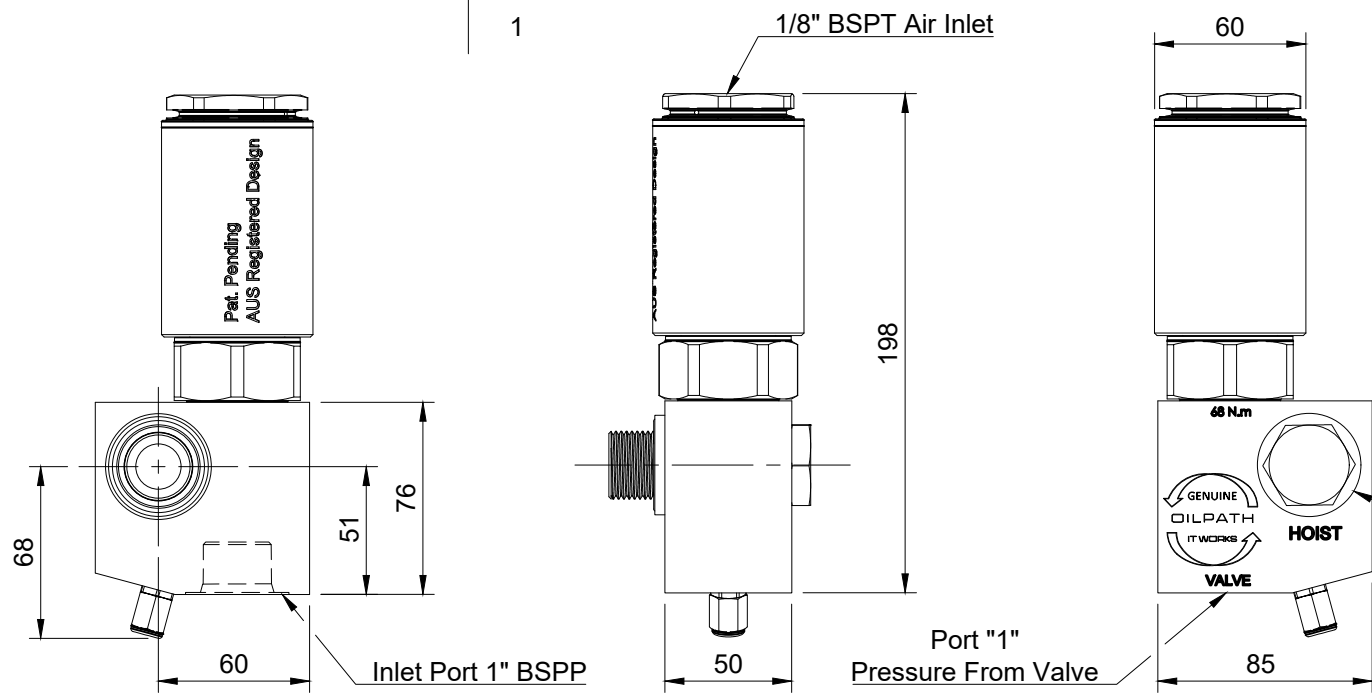
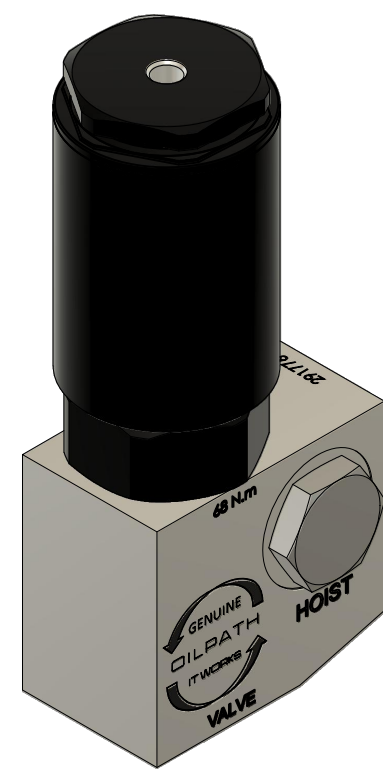

Port "2" - Nippled to Cylinder Port

ALL DIMENSIONS IN MM

Hoist Blocking Valve			
Maximum Flow	180 L/min	Working Pressure	3000 PSI

OP-HBV



20/04/2023