

# AIRSAFE®

*High-flow rate suction system*

*A patented aerosol aspiration stream solution  
for high-risk procedures*



CE



made in Italy



virus threat  
reduction



high-flow  
rate



multi stages  
of filtration



droplet  
separation



effortless  
sanitification



Medical Device

## why

**Contamination due to infected aerosol** is a new challenge in the field of air safety in medical context, as hospitals, clinics and any activity involving a direct contact between patient and healthcare professional.

Exposure of healthcare professionals to **microbes, virus and bacteria** can be reduced by PPE. But as those are passive protection, **they do not stop particles from scattering and transporting pathogens**, polluting the environment and make it hard to sanitize.

As it is already the case for industrial pollutants, the ideal solution for emissions is **to extract them straight from the source**, before they are released into the environment. Airsafe® line is founded on capture of pollutants from their source. Technological, aerodynamic, filtering and capacity features of the entire line are optimized to grant the final output: **active protection of patients and operators**.



## applications

Airsafe® filtering line includes mobile, stationary and centralized systems. All these already protect patient and **healthcare professional successfully** in any operation foreseeing patient/operator physical proximity, and – more importantly – during high-risk procedures, **with aerosol emission**.

endotracheal  
intubation

non-invasive  
ventilation

tracheostomy

manual ventilation

extubation

bronchoscopy

gastroscopy

high flow  
oxygen delivery

aerosol  
therapy delivery

dental procedures

dermatological  
surgery

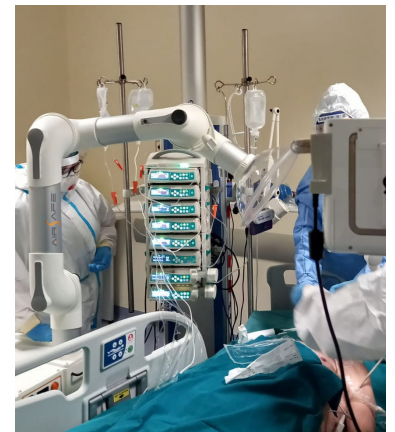

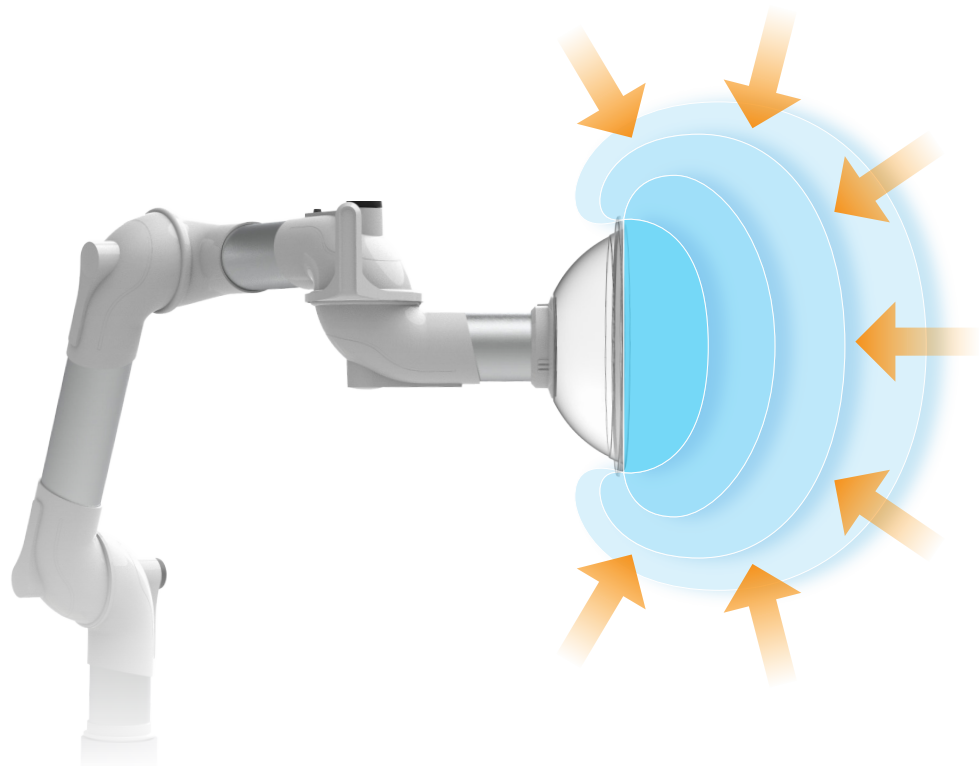

**High-flow capacity** creates negative pressure around the 350mm-diameter hood, ensuring an effective capture of aerosol and extra-oral nebulization.

**AirSafe®** systems employ laboratory suction arm consisting in polypropylene pivoting joints and 100mm-diameter anodized aluminium pipes.

Self-supporting arms are easy to locate close to the operation area, so to make aspiration effective without hindering operators' motion.

### Mobile Machines



### Complex Centrifugated Solutions

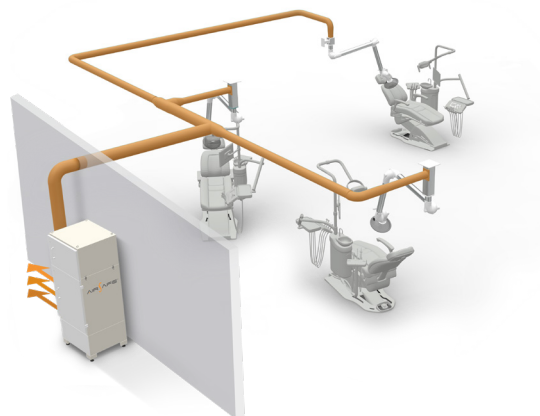

### Fixed Wall-Mounted Systems



**Fitted With an Extendable Arm to Reach Close to the Patient.**

# VX400M



MOBILE UNIT

extractor		
engine	watt	180 220V/1/50Hz
flow rate	mc/h	400
	lt/min.	6.600
size	mm	495 x 590 x 790h
weight	Kg	53
arm lenght	mm	1300 / 1650 / 1900
		2100 / 2650
arm	Ø mm	100
sound level	dB(A)	≤ 60

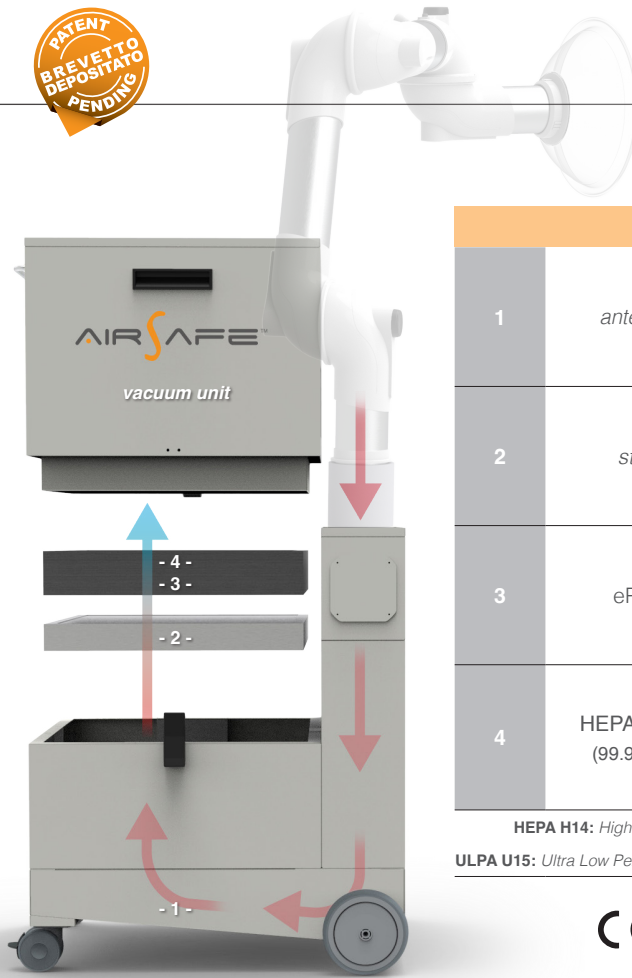

filtration		
1	anteroom for fluids with drain	
2	stainless filter separator	
3	ePM10 80% - ISO 16890	
4	HEPA H14 (99.99%)	U15 (99.9995%)

HEPA H14: High Efficiency 99.99% @ 0.3 micron

ULPA U15: Ultra Low Penetration Filter 99.9995% @ 0.12 micron

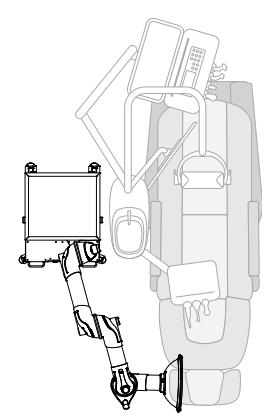
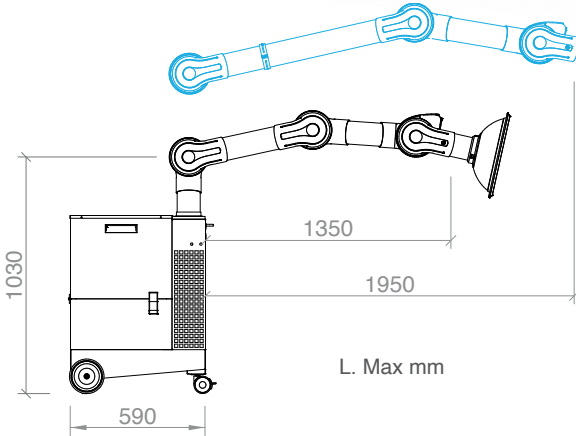

Tel. +852 2892 0033  
Fax. +852 2892 1433  
admin@synemed.info



hkmedicalstore.com



by  
GAMMA IMPIANTI S.r.l.

Via Stroppiana 15  
10071 Borgaro T.se (TO)  
ITALY

Tel. +39 011 450 2031  
Fax. +39 011 470 3927  
info@medicalairsafe.com



medicalairsafe.com