

# STANDARD ELBOWS & BENDS

## STANDARD RADIUS ELBOWS

- 30° AND 60° ELBOWS AVAILABLE
- 11 GAUGE ELBOWS AVAILABLE (STRAIGHT ENDS ONLY)
- EXPANDED ENDS STANDARD THROUGH 6" SIZE
- EXPANDED ONE END AVAILABLE
- STRAIGHT ENDS AVAILABLE ON ALL SIZES BY REQUEST

A (OD)	B (CLR)	GAUGE	TAN.	C	90° PART NO.	C	45° PART NO.
2"	5"	16	2"	7"	EL-202	4-1/16"	EL-201
2-1/8"	5"	16	2"	7"	EL-212	4-1/16"	EL-211
2-1/2"	6"	16	2"	8"	EL-252	4-1/2"	EL-251
3"	7-1/2"	16	2"	9-1/2"	EL-302	5-1/8"	EL-301
3-1/2"	8-3/4"	16	2"	10-3/4"	EL-352	5-5/8"	EL-351
4"	10"	16	2"	12"	EL-402	6-1/8"	EL-401
5"	12-1/2"	14	2-5/8"	15-1/8"	EL-502	7-13/16"	EL-501
6"	15"	14	3-1/4"	18-1/4"	EL-602	9-7/16"	EL-601
8"	20"	14	4-1/4"	24-1/4"	EL-802	12-9/16"	EL-801
10"	32"	12	15"	47"	EL-1002*	28-1/4"	EL-1001*
12"	36"	12	6-1/4"	42-1/4"	EL-1202**	21-5/32"	EL-1201**
14"	36"	12	7-1/4"	43-1/4"	EL-1402**	22-5/32"	EL-1401**

- Expansion depth for standard and short radius elbows 1-3/8" through 4" OD and 1-5/8" for 5" and 6" OD
- Stainless parts (10" OR LARGER OD) are segmented
- \* Stainless parts are segmented
- \*\* Segmented

## SHORT RADIUS ELBOWS

- 30° AND 60° ELBOWS AVAILABLE
- 11 GAUGE ELBOWS AVAILABLE (STRAIGHT ENDS ONLY)
- EXPANDED ENDS STANDARD THROUGH 6" SIZE
- EXPANDED ONE END AVAILABLE
- STRAIGHT ENDS AVAILABLE ON ALL SIZES BY REQUEST

A (OD)	B (CLR)	GAUGE	TAN.	C	90° PART NO.	C	45° PART NO.
2"	3"	16	2"	5"	SR-242	3-1/4"	SR-241
2-1/8"	3-1/2"	16	2"	5-1/2"	SR-212	3-7/16"	SR-211
2-1/2"	4"	16	2"	6"	SR-252	3-21/32"	SR-251
3"	4-1/2"	16	2"	6-1/2"	SR-342	3-7/8"	SR-341
3-1/2"	5"	16	2"	7"	SR-352	4-1/16"	SR-351
4"	6"	16	2"	8"	SR-442	4-1/2"	SR-441
5"	7-1/2"	14	2-5/8"	10-1/8"	SR-542	5-23/32"	SR-541
6"	9"	14	3-1/4"	12-1/4"	SR-642	6-31/32"	SR-641
8"	12"	14	4-1/4"	16-1/4"	SR-842	9-7/32"	SR-841
10"	15"	12	5-1/4"	20-1/4"	SR-1042**	13-17/32"	SR-1041**
12"	18"	12	6-1/4"	24-1/4"	SR-1242**	16-3/16"	SR-1241**

- Expansion depth for standard and short radius elbows: 1-3/8" through 4" OD and 1-5/8" for 5" and 6" OD
- \*\* Segmented

### KEY

OD = Outside Diameter  
 CLR = Center Line Radius  
 TAN = Tangent Length  
 D = Expansion Depth 1-3/8" through 4" OD, 1-5/8" for 5" and 6" OD  
 E = Inside Diameter (ID) = A Outside Diameter (OD)

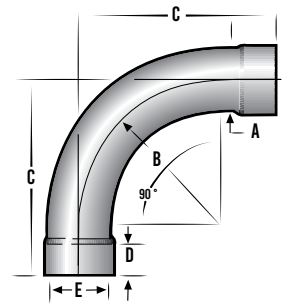

90° STANDARD RADIUS ELBOW

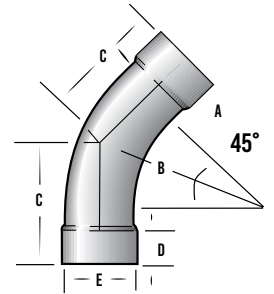

45° STANDARD RADIUS ELBOW

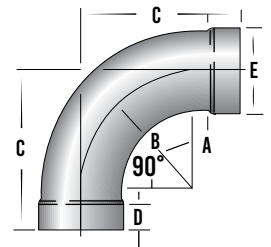

90° SHORT RADIUS ELBOW

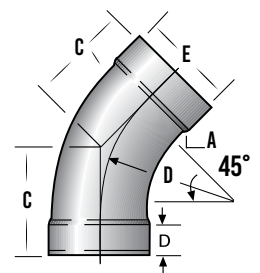

45° SHORT RADIUS ELBOW

### WHEN ORDERING, PLEASE SPECIFY TYPE OF MATERIAL

- Carbon
- Stainless
- Aluminum
- Galvanized Steel

# STANDARD ELBOWS & BENDS

All reference dimensions are nominal

## KEY

OD = Outside Diameter  
 CLR = Center Line Radius  
 C = Center to end  
 All reference dimensions are nominal

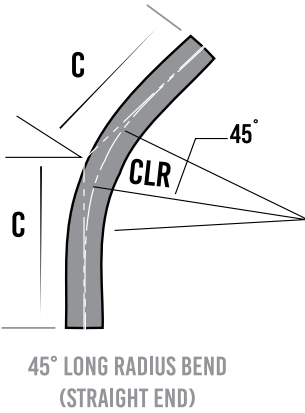
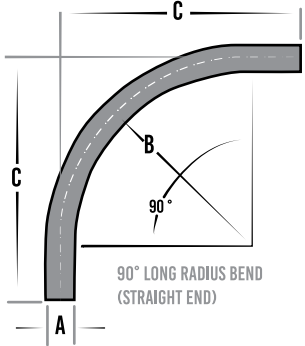

## STANDARD LONG RADIUS BENDS

• EXPANDED ENDS AVAILABLE UPON REQUEST, EXCEPT ON 8" AND 10" BENDS & ALL 11 GAUGE BENDS

A (OD)	B (CLR)	GAUGE	C	90° PART NO.	C	45° PART NO.
2-1/8"	24"	16	30"	16-212242	15-15/16"	16-212241
2-1/8"	24"	11	30"	11-212242	15-15/16"	11-212241
2-1/8"	36"	16	42"	16-212362	20-15/16"	16-212361
2-1/8"	36"	11	42"	11-212362	20-15/16"	11-212361
2-1/2"	24"	16	30"	16-250242	15-15/16"	16-250241
2-1/2"	24"	11	30"	11-250242	15-15/16"	11-250241
2-1/2"	36"	16	42"	16-250362	20-15/16"	16-250361
2-1/2"	36"	11	42"	11-250362	20-15/16"	11-250361
3"	24"	16	30"	16-300242	15-15/16"	16-300241
3"	24"	11	30"	11-300242	15-15/16"	11-300241
3"	30"	16	36"	16-300302	18-7/16"	16-300301
3"	30"	11	36"	11-300302	18-7/16"	11-300301
3"	36"	16	42"	16-300362	20-15/16"	16-300361
3"	36"	11	42"	11-300362	20-15/16"	11-300361
3"	38"	16	44"	16-300382	21-3/4"	16-300381
3"	38"	11	44"	11-300382	21-3/4"	11-300381
3"	48"	16	54"	16-300482	25-7/8"	16-300481
3"	48"	11	54"	11-300482	25-7/8"	11-300481
3-1/2"	30"	16	37"	16-350302	19-7/16"	16-350301
3-1/2"	30"	11	37"	11-350302	19-7/16"	11-350301
3-1/2"	36"	16	43"	16-350362	21-15/16"	16-350361
3-1/2"	36"	11	43"	11-350362	21-15/16"	11-350361
3-1/2"	48"	16	55"	16-350482	26-7/8"	16-350481
3-1/2"	48"	11	55"	11-350482	26-7/8"	11-350481
4"	24"	16	32"	16-400242	17-15/16"	16-400241
4"	24"	11	32"	11-400242	17-15/16"	11-400241
4"	30"	16	38"	16-400302	20-7/16"	16-400301
4"	30"	11	38"	11-400302	20-7/16"	11-400301
4"	36"	16	44"	16-400362	22-15/16"	16-400361
4"	36"	11	44"	11-400362	22-15/16"	11-400361
4"	48"	16	56"	16-400482	27-7/8"	16-400481
4"	48"	11	56"	11-400482	27-7/8"	11-400481
4"	60"	16	68"	16-400602	32-7/8"	16-400601
4"	60"	11	68"	11-400602	32-7/8"	11-400601
5"	30"	14	40"	14-500302	22-7/16"	14-500301
5"	30"	11	40"	11-500302	22-7/16"	11-500301
5"	48"	14	58"	14-500482	29-7/8"	14-500481
5"	48"	11	58"	11-500482	29-7/8"	11-500481
6"	30"	14	42"	14-600302	24-7/16"	14-600301
6"	30"	11	42"	11-600302	24-7/16"	11-600301
6"	48"	14	60"	14-600482	31-7/8"	14-600481
6"	48"	11	60"	11-600482	31-7/8"	11-600481
6"	60"	14	72"	14-600602	36-7/8"	14-600601
6"	60"	11	72"	11-600602	36-7/8"	11-600601
8"	32"	14	48"	14-800322	29-1/4"	14-800321
8"	32"	11	48"	11-800322	29-1/4"	11-800321
8"	48"	14	64"	14-800482	31-7/8"	14-800481
8"	48"	11	64"	11-800482	31-7/8"	11-800481
10"	48"	12	70"	12-1000482*	41-7/8"	12-1000481*

• Nominal standard tangent is two times tube OD, 6" minimum • Nominal standard tangent for 10" bend is 22"  
 • All standard bends have straight ends • Stainless parts are segmented

WHEN ORDERING,  
 PLEASE SPECIFY  
 TYPE OF MATERIAL

- Carbon
- Stainless
- Aluminum
- Galvanized Steel

Catalog Part Variations Available Upon Request

Give us a call if you can't find exactly what you need!