

STANDARD LONG RADIUS BENDS

STRAIGHT ENDS *Zinc-Coated (Galvanized) Steel*

A-OD	B-CLR	C-CENTER TO END DIMENSION	TAN	GAUGE	PART #
2-1/4"	18"	21-7/8"	3-7/8"	20	29218
2-1/4"	24"	30-1/3"	6-1/8"	20	29224
2-1/4"	42"	48"	6"	20	29242
3"	24"	30"	6"	18	39224
3"	30"	36"	6"	18	39230
3"	38"	48-1/2"	10-1/2"	18	39238
3"	48"	62-3/4"	13-1/4"	18	39248
4"	36"	47-7/16"	11-7/16"	16	49236
4"	48"	61-1/4"	13-1/4"	16	49248
4"	60"	74"	12"	16	49260
4-1/2"	20"	27-7/8"	5-5/16"	16	45220
4-1/2"	24"	37-3/4"	11-1/2"	16	45224
4-1/2"	30"	43-3/4"	11-1/2"	16	45230
4-1/2"	48"	63-1/2"	13-1/4"	16	45248
4-1/2"	60"	72"	12-7/8"	16	45260
6"	30"	43-7/16"	13-7/16"	16	69230
6"	36"	48"	12"	16	69236
6"	48"	70-3/8"	22-3/8"	16	69248
6"	60"	72-7/8"	12-7/8"	16	69260
4"x 7"(FLAT BEND)	48"	70-7/16"	22-7/16"	16	70248*
4"x 7"(EDGE BEND)	48"	71-1/16"	23-1/16"	16	7E248**
4"x 7"(FLAT BEND)	60"	84"	24"	14	70260*
4"x 7"(EDGE BEND)	60"	84"	24"	14	7E260**

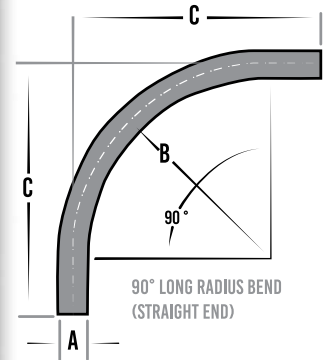

ONE END EXPANDED (ID OF EXPANSION = TUBE OD) *Zinc-Coated (Galvanized) Steel*

A-OD	B-CLR	C-CENTER TO END	D-EXP DEPTH	TAN	GAUGE	PART #
2-1/4"	18"	21-7/8"	1-3/4"	3-7/8"	20	29218-1
2-1/4"	24"	30-1/8"	1-3/4"	6-1/8"	20	29224-1
2-1/4"	42"	48"	1-3/4"	6"	20	29242-1
3"	24"	30"	2-1/8"	6"	18	39224-1
3"	30"	36"	2-1/8"	6"	18	39230-1
3"	38"	48-1/2"	2-1/8"	8-1/4"	18	39238-1
3"	48"	62-3/4"	2-1/8"	13-1/4"	18	39248-1
4"	36"	47-7/16"	3-3/4"	11-7/16"	16	49236-1
4"	48"	61-1/4"	3-3/4"	13-1/4"	16	49248-1
4"	60"	74"	3-3/4"	12"	16	49260-1
4-1/2"	20"	27-7/8"	3-3/4"	5-5/16"	16	45220-1
4-1/2"	24"	37-3/4"	3-3/4"	11-1/2"	16	45224-1
4-1/2"	30"	43-3/4"	3-3/4"	11-1/2"	16	45230-1
4-1/2"	48"	63-1/2"	3-3/4"	13-1/4"	16	45248-1
4-1/2"	60"	72"	3-3/4"	12-7/8"	16	45260-1
6"	30"	43-7/16"	4-3/4"	13-7/16"	16	69230-1
6"	36"	48"	4-3/4"	12"	16	69236-1
6"	48"	70-3/8"	4-3/4"	22-3/8"	16	69248-1
6"	60"	72-7/8"	4-3/4"	12-7/8"	16	69260-1
4"x7"(FLAT BEND)	48"	70-7/16"	4-3/4"	22-7/16"	16	70248-1*
4"x7"(EDGE BEND)	48"	71-1/16"	4-3/4"	23-1/16"	16	7E248-1**

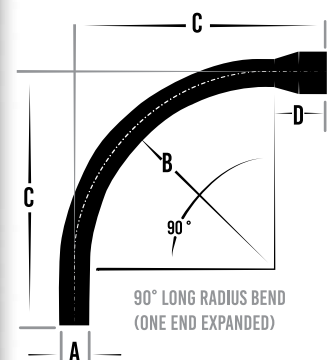

*Neutral axis through 7" dimension
 **Neutral axis through 4" dimension